

*Changes for the Better*

**MITSUBISHI CNC**

**700 Series**

**Connection Manual**



Microsoft® and Windows® are either registered trademarks or trademarks of Microsoft Corporation in the United States and/or other countries.

Intel®, Pentium® and Celeron® are either registered trademarks or trademarks of Intel Corporation and its subsidiaries in the United States and other countries.

SanDisk and SanDisk logos are registered trademarks of SanDisk Corporation, U.S.A.

MELDAS is a registered trademark of Mitsubishi Electric Corporation.





Other company and product names that appear in this manual are registered trademarks or trademarks of their respective companies.

## Introduction

This manual is called MITSUBISHI CNC 700 Series CONNECTION MANUAL and covers the items related to installation, connection and maintenance of this NC unit. Read this manual thoroughly before using. For safe use, fully understand "Precautions for Safety" on the next page first.

### Details described in this manual:

#### CAUTION

-  For items described as "Restrictions" or "Usable State" in this manual, the instruction manual issued by the machine tool builder takes precedence over this manual.
-  Items that are not described in this manual must be interpreted as "not possible".
-  This manual is written on the assumption that all option functions are added. Confirm the specifications issued by the machine tool builder before use.
-  Refer to the Instruction Manual issued by each machine tool builder for details on each machine tool.
-  Some screens and functions may differ depending on each NC system (or version), and some functions may not be possible. Please confirm the specifications before use.

The numerical control unit is configured of the control unit, display unit, operation board, servo drive unit, spindle drive unit, power supply unit + driver, servomotor, and spindle motor, etc.

In this manual, the following items are generically called the "controller".

- Control unit
- Display unit
- Operation board
- Numerical control unit peripheral devices (input/output unit, safety unit)

In this manual, the following items are generically called the "drive unit".

- Servo drive unit
- Spindle drive unit
- Power supply unit + driver

In this manual, the following items are generically called the "motor".

- Servomotor
- Spindle motor

## Precautions for Safety

Always read this manual and enclosed documents before installation, operation, maintenance and inspection to ensure correct usage. Thoroughly understand the basics, safety information and precautions of the devices before using.

This manual classifies the safety precautions into "**DANGER**", "**WARNING**" and "**CAUTION**".



When the user could be subject to imminent fatalities or serious injuries if handling is mistaken.



When the user could be subject to fatalities or serious injuries if handling is mistaken.



When the user could be subject to minor or moderate injuries or the property could be damaged if handling is mistaken.









Note that the items under " **CAUTION**" could lead to serious consequences as well depending on the situation. Please follow all items listed in "Precautions for Safety" as they are equally important.

## For Safe Use

This product is not designed or manufactured on the assumption that the product will be used for the equipment or systems that are to be subject to any fatal consequences. Please inquire our customer service department about any particular usage other than the normal usage as a machine tool.

### 1. Items related to prevention of electric shocks



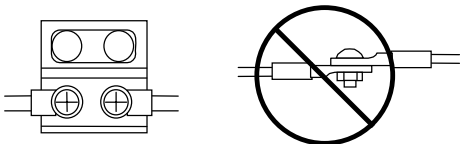

#### **WARNING**

-  Do not open or remove the front cover while the power is ON or during operation. The high voltage terminals and charged sections will be exposed, and this could result in electric shocks.
-  Do not remove the front cover even when the power is OFF, except for the wiring works or periodic inspections. The inside of the controller and drive unit are charged, and this could result in electric shocks.
-  Always wait at least 15 minutes after turning the power OFF. Then, check the voltage with a tester, etc., before wiring works, inspections or connecting with peripheral devices. Failure to observe this could result in electric shocks.
-  Earth ground the controller, drive unit and motor according to the local laws. (In Japan, ground the 200V Series input products with Class C or higher protective grounding and the 400V Series input with Class D or higher protective grounding.)
-  All wiring works, maintenance and inspections must be carried out by a qualified technician. Failure to observe this could result in electric shocks. Contact your nearby Service Center or Service Station for replacing parts and servicing.
-  Wire the controller, drive unit and motor after installation. Failure to observe this could result in electric shocks.
-  Do not operate the switches with wet hands. Failure to observe this could result in electric shocks.
-  Do not damage, apply excessive stress, place heavy things on or sandwich the cables. Failure to observe this could result in electric shocks.
-  Insulate the power lead using a fixed terminal block. Failure to observe this could result in electric shocks.



## 2. Items related to prevention of fire

### CAUTION







-  Install the controller, drive unit, motor and regenerative resistor on non-combustible material. Installation directly on or near combustible materials could result in fires.
-  If any malfunction in the unit is observed, shut off the power at the unit's power supply side. Continuous flow of large current could result in fires.
-  Install an appropriate no fuse breaker (NFB) and contactor (MC) on the power input section of the drive unit and configure the sequence that shuts the power off upon drive unit's emergency stop or alarm.
-  When a breaker is shared for multiple power supply units, the breaker may not function upon short-circuit failure in a small capacity unit. Do not share a breaker for multiple units as this is dangerous.
-  Incorrect wiring and connections could cause the devices to damage or burn.

## 3. Items related to prevention of bodily injury or property damage

### DANGER

-  When transporting or installing a built-in IPM spindle or linear servomotor, be careful so that your hand or property will not be trapped in the motors or other metal objects. Also keep the devices with low magnetic tolerance away from the product.

### CAUTION

















-  Do not apply voltages to the connectors or terminals other than voltages indicated in the connection manual for the controller or specifications manual for the drive unit. Failure to observe this could cause the devices to rupture or damage, etc.
-  Incorrect connections could cause the devices to rupture or damage, etc. Always connect the cables to the indicated connectors or terminals.
-  Incorrect polarity (+ -) could cause the devices to rupture or damage, etc.
-  Persons wearing medical devices, such as pacemakers, must stay away from this unit. The electromagnetic waves could adversely affect the medical devices.
-  Fins on the rear of the unit, regenerative resistor and motor, etc., will be hot during operation and for a while after the power has been turned OFF. Do not touch or place the parts and cables, etc. close to these sections. Failure to observe this could result in burns.
-  Do not enter the machine's movable range during automatic operation. Keep your hands, feet or face away from the spindle during rotation.

## 4. General precautions













Always follow the precautions below. Incorrect handling could result in faults, injuries or electric shocks, etc.

### (1) Transportation and installation

#### CAUTION





-  Correctly transport the products according to the mass.
-  Use motor's suspension bolts to transport the motor itself. Do not use it to transport the motor after installation onto the machine.
-  Do not stack the products exceeding the indicated limit.
-  Do not hold the cables, shaft or detector when transporting the motor.
-  Do not transport the controller or drive unit by suspending or holding the connected wires or cables.
-  Do not hold the front cover when transporting the unit, or the front cover could come off, causing the unit to drop.
-  Install on a non-combustible place where the unit's or motor's mass can be withstood according to the instruction manual.
-  The motor does not have a complete water-proof (oil-proof) structure. Do not allow oil or water to contact or enter the motor. Prevent the cutting chips from being accumulated on the motor as they easily soak up oil.
-  When installing the motor facing upwards, take measures on the machine side so that gear oil, etc., will not enter the motor shaft.
-  Do not remove the detector from the motor. (The detector installation screw is treated with sealing.)
-  Do not allow foreign matters, especially, conductive foreign matters such as screws or metal chips, or combustible foreign matters such as oil, to enter the controller, drive unit or motor. Failure to observe this could result in rupture or damage.
-  Do not get on the product or place heavy objects on it.
-  Provide prescribed distance between the controller/drive unit and inner surface of the control panel/other devices.
-  Do not install or operate the controller, drive unit or motor that is damaged or has missing parts.
-  Take care not to cut hands, etc. with the heat radiating fins or metal edges.
-  Do not block the intake/outtake ports of the motor with the cooling fan.
-  Install the controller's display section and operation board section on the spot where cutting oil will not reach.

## CAUTION

-  The controller, drive unit and motor are precision devices, so do not drop or apply thumping vibration and strong impacts on them.
-  Hard disk unit is a precision device, so do not drop or apply strong impacts on it.
-  Store and use the units according to the environment conditions indicated in each specifications manual.
-  Securely fix the motor to the machine. The motor could come off during operation if insecurely fixed.
-  Always install the motor with reduction gear in the designated direction. Failure to observe this could result in oil leaks.
-  Always install a cover, etc., over the shaft so that the rotary section of the motor cannot be touched during motor rotation.
-  When installing a coupling to the servomotor shaft end, do not apply impacts by hammering, etc. The detector could be damaged.
-  Use a flexible coupling when connecting with a ball screw, etc., and keep the shaft core deviation smaller than the tolerable radial load of the shaft.
-  Do not use a rigid coupling as an excessive bending load will be applied on the shaft and could cause the shaft to break.
-  Do not apply a load exceeding the tolerable level onto the motor shaft. The shaft or bearing could be damaged.
-  Before using this product after a long period of storage, please contact the Mitsubishi Service Station or Service Center.
-  Following the UN recommendations, battery units and batteries should be transported based on the international regulations such as those determined by International Civil Aviation Organization (ICAO), International Air Transport Association (IATA), International Maritime Organization (IMO) and U.S. Department of Transportation (DOT).

### (2) Items related to wiring

## CAUTION

-  Correctly wire this product. Failure to observe this could result in motor runaway, etc.
-  Do not install a phase advancing capacitor, surge absorber or radio noise filter on the output side of the drive unit.
-  Correctly connect the output side (terminal U, V, W). The motor will not run properly if incorrectly connected.
-  Always install an AC reactor per each power supply unit.



## ⚠ CAUTION

- ⚠ Always install an appropriate breaker per each power supply unit. A breaker cannot be shared for multiple power supply units.
- ⚠ Do not directly connect a commercial power supply to the motor. Failure to observe this could result in faults.
- ❗ When using an inductive load such as relays, always connect a diode in parallel to the load as a noise countermeasure.
- ❗ When using a capacitive load such as a lamp, always connect a protective resistor in series to the load to suppress rush currents.
- ⚠ Do not mistake the direction of the surge absorption diode to be installed on the DC relay for the control output signal. If mistaken, the signal will not be output due to fault in the drive unit, and consequently the protective circuit, such as emergency stop, could be disabled.

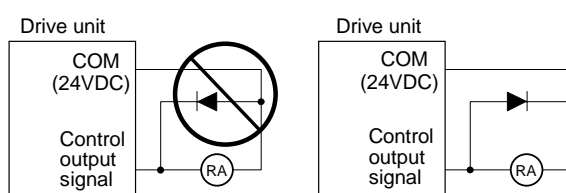

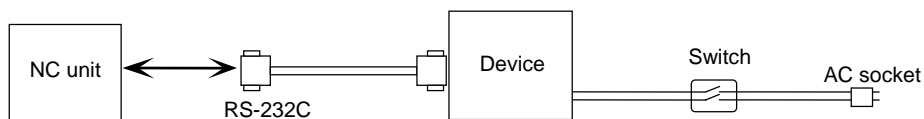

- ⊘ Do not connect or disconnect the connection cables between each unit while the power is ON.
- ⚠ Do not connect or disconnect the PCBs while the power is ON.
- ⚠ Do not pull the cables when connecting/disconnecting it.
- ⚠ Securely tighten the cable connector fixing screw or fixing mechanism. Insufficient fixing could result in deviation during operation.
- ⚡ Always treat the shield cables indicated in the Connection Manual with grounding measures such as cable clamps.
- ⚠ Separate the signal wire from the drive line or power line when wiring.
- ⚠ Use wires and cables whose wire diameter, heat resistance level and bending capacity are compatible with the system.
- ⚡ Ground the device according to the requirements of the country where the device is to be used.
- ⚠ Wire the heat radiating fins and wires so that they do not contact.
- ⚠ When using the RS-232C device as a peripheral device, caution must be paid for connector connection/disconnection. Always use a double-OFF type AC power supply switch on the device side, and connect/disconnect the connector with the AC power supply on the device side OFF.















### (3) Adjustments

#### CAUTION

-  Check and adjust programs and each parameter before starting operation. Failure to observe this could result in unpredictable operations depending on the machine.
-  Do not make drastic adjustments or changes as the operation could become unstable.

### (4) Usage

#### CAUTION

-  Install an external emergency stop circuit so that the operation can be stopped and the power turns OFF immediately when unforeseen situation occurs. A contactor, etc., is required in addition to the shutoff function mounted in the controller.
-  Turn OFF the power immediately if any smoke, abnormal noise or odor is generated from the controller, drive unit or motor.
-  Only a qualified technician may disassemble or repair this product.
-  Do not alter.
-  Use a noise filter, etc. to reduce the effect of electromagnetic disturbances in the case where electromagnetic disturbances could adversely affect the electronic devices used near the drive unit.
-  Use the drive unit, motor and each regenerative resistor with the designated combination. Failure to observe this could result in fires or faults.
-  The combination of the motor and drive unit that can be used is determined. Be sure to check the models of motor and drive unit before test operation.
-  The brakes (electromagnetic brakes) mounted in the servomotor are used for the purpose of holding, and must not be used for normal braking. Also, do not run the motor with the motor brake applied. Motor brake is used for the purpose of holding.
-  For the system running via a timing belt, install a brake on the machine side so that safety can be ensured.
-  Be sure to confirm SERVO OFF (or READY OFF) when applying the electromagnetic brake. Also, be sure to confirm SERVO ON prior to releasing the brake.
-  When using the DC OFF type electromagnetic brake, be sure to install a surge absorber on the brake terminal.
-  Do not connect or disconnect the cannon plug while the electromagnetic brake's power is ON. The cannon plug pins could be damaged by sparks.
-  After changing programs/parameters, or after maintenance/inspection, always carry out a test operation before starting actual operation.

## ⚠ CAUTION

- ⚠ Use the power that are complied with the power specification conditions (input voltage, input frequency, tolerable instantaneous power failure time) indicated in each specifications manual.
- ⚠ When making detector cables, do not mistake connection. Failure to observe this could result in malfunction, runaway or fire.
- ⚠ When using NC Card, first power ON the NC Card, and then the base I/O unit. If the base I/O unit is powered ON first, current flows from the connection cable to the NC Card, resulting in malfunction in the PC or the cards installed in the PC.

### (5) Troubleshooting

## ⚠ CAUTION



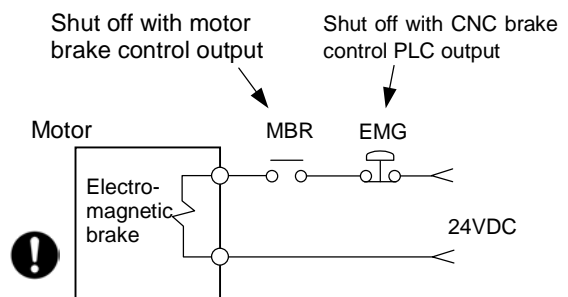





- ⚠ Use a motor with electromagnetic brakes or establish an external brake mechanism for the purpose of holding; this serves as countermeasures for possible hazardous situation caused by power failure or product fault.
- ⚠ Use a double circuit structure for the electromagnetic brake's operation circuit so that the brakes will activate even when the external emergency stop signal is issued.



- ⚠ The machine could suddenly restart when the power is restored after an instantaneous power failure, so stay away from the machine. (Design the machine so that the operator safety can be ensured even if the machine restarts.)
- ⚠ To secure the absolute position, do not shut off the servo drive unit's control power supply when its battery voltage drops (warning 9F) in the servo drive unit side.
- ⚠ If the battery voltage drop warning alarm occurs in the controller side, make sure to back up the machining programs, tool data and parameters, etc. with the input/output device before replacing the battery.  
Depending on the level of voltage drop, memory loss could have happened. In that case, reload all the data backed up before the alarm occurrence.



## (6) Maintenance, inspection and part replacement

### CAUTION

-  Periodically back up the programs, tool data and parameters to avoid potential data loss. Also, back up those data before maintenance and inspections.
-  When replacing the battery on the controller side, the machining programs, tool data and parameters should be backed up with the input/output device beforehand.  
In case the memory is damaged in replacing the batteries, reload all the data backed up before replacing the battery.
-  The electrolytic capacitor's capacity will drop due to deterioration. To prevent secondary damage due to capacitor's faults, Mitsubishi recommends the electrolytic capacitor to be replaced approx. every five years even when used in a normal environment. Contact the Service Center or Service Station for replacements.
-  Do not perform a megger test (insulation resistance measurement) during inspection.
-  Do not replace parts or devices while the power is ON.
-  Do not short-circuit, charge, overheat, incinerate or disassemble the battery.
-  The hard disk unit has a service life, and must be replaced before its expiration.
-  As a precautionary measure, always back up the customer's data stored in the hard disk unit. The safety of the customer's data stored in the hard disk unit cannot be guaranteed.
-  There may be a unit filled with substitute Freon in the heat radiating fins of the 37kW or smaller unit. Be careful not to break the heat radiating fins during maintenance or replacement.

## (7) Disposal

### CAUTION

-  Take the batteries and backlights for LCD, etc., off from the controller, drive unit and motor, and dispose of them as general industrial wastes.
-  Do not alter or disassemble controller, drive unit, or motor.
-  Collect and dispose of the spent batteries and the backlights for LCD according to the local laws.

## (8) General precautions

To explain the details, drawings given in the instruction manual, etc., may show the unit with the cover or safety partition removed. When operating the product, always place the cover or partitions back to their original position, and operate as indicated in the instruction manual, etc.

# CONTENTS

<b>1. Introduction .....</b>	<b>1</b>
<b>2. System Configuration.....</b>	<b>2</b>
2.1 System Basic Configuration Drawing .....	2
2.2 General Connection Diagram .....	3
2.2.1 Display Unit: FCU7-DA201-11/FCU7-DA211-11 .....	3
2.2.2 Display Unit: FCU7-DA315-11/FCU7-DA415-11/FCU7-DA445-11/FCU7-DA335-11/FCU7-DA435-11 ...	4
2.3 List of Configuration Units.....	5
2.3.1 Control Unit: FCU7-MU001/FCU7-MU002/FCU7-MU011/FCU7-MA011 .....	5
2.3.2 Display Unit: FCU7-DA201/FCU7-DA211/FCU7-DA315 /FCU7-DA415/FCU7-DA445/FCU7-DA335/FCU7-DA435 .....	6
2.3.3 Operation Panel I/O Unit: FCU7-DX670/FCU7-DX671/FCU7-DX770/FCU7-DX771 .....	7
2.3.4 Keyboard Unit : FCU7-KB021/FCU7-KB022/FCU7-KB041 .....	7
2.3.5 Remote I/O Unit: FCUA-DX100/DX110/DX120/DX140/DX101/DX111/DX121/DX141 .....	8
2.3.6 Scan I/O: HR357/HR347 .....	8
2.3.7 Card-sized I/O Card: HR361/HR371/HR381/HR383 .....	8
2.3.8 Extended I/O Card: QY231 .....	9
2.3.9 Front IC Card Interface: FCU7-EP102-1 (option) .....	9
2.3.10 Hard Disk Unit: FCU7-HD001-1 .....	9
2.3.11 Floppy Disk Unit: FCU7-FD221.....	9
2.3.12 Expansion Unit: FCU7-EX891 .....	10
2.3.13 Expansion Card .....	10
2.3.14 External Power Supply Unit: PD25/PD27 .....	10
<b>3. General Specifications (Environment Conditions) .....</b>	<b>11</b>
3.1 Environment Conditions in Operation Box.....	11
3.2 Environment Specifications in Electric Cabinet.....	12
3.3 Remote I/O Unit.....	13
3.4 Servo / Spindle.....	13
3.5 Heat Radiation Countermeasures .....	14
3.6 Noise Countermeasures .....	17
3.6.1 Connection of FG (Frame Ground).....	17
3.6.2 Shield Clamping of Cables .....	18
3.6.3 Connecting Spark Killers.....	18
<b>4. Outline Drawing .....</b>	<b>19</b>
4.1 Control Unit.....	19
4.2 Display Unit.....	24
4.2.1 FCU7-DA201 (8.4-type).....	24
4.2.2 FCU7-DA211 / FCU7-DA315 / FCU7-DA415 / FCU7-DA445 (10.4-type) .....	25
4.2.3 FCU7-DA335 / FCU7-DA435 (15-type) .....	27
4.2.4 FCU7-DA201 (8.4-type) / FCU7-DA211 (10.4-type) Rear View.....	29
4.2.5 FCU7-DA315 / FCU7-DA415 / FCU7-DA445 / FCU7-DA335 / FCU7-DA435 Rear View ..	30
4.2.6 FCU7-EP102 (Front IC Card I/F Unit).....	31
4.3 Operation Panel I/O Unit.....	32
4.3.1 FCU7-DX670 / FCU7-DX671 / FCU7-DX770 / FCU7-DX771 Outline Drawing.....	32
4.4 Keyboard Unit.....	33
4.4.1 FCU7-KB021 / FCU7-KB022 (ONG Layout).....	33
4.4.2 FCU7-KB041 (ABC Layout).....	33
4.5 Hard Disk Unit.....	34
4.5.1 FCU7-HD001-1 .....	34
4.6 Floppy Disk Unit.....	35
4.6.1 FCU7-FD221-1 .....	35

4.7 Card-sized I/O Card.....	36
4.7.1 HR361 / HR371 / HR381 / HR383.....	36
4.8 Remote I/O Unit Outline.....	38
4.8.1 FCUA-DX100 / FCUA-DX110 / FCUA-DX120 / FCUA-DX140 / FCUA-DX101 / FCUA-DX111 / FCUA-DX121 / FCUA-DX141 .....	38
4.9 Grounding Plate and Clamp Fitting.....	39
<b>5. Panel Cut Dimension Drawing / Installation Dimension Drawing .....</b>	<b>40</b>
5.1 Control Unit.....	40
5.2 Display Unit.....	41
5.2.1 FCU7-DA201 (8.4-type).....	41
5.2.2 FCU7-DA211 / FCU7-DA315 / FCU7-DA415 / FCU7-DA445 (10.4-type) .....	42
5.2.3 FCU7-DA335 / FCU7-DA435 (15-type) .....	43
5.3 Operation Panel I/O Unit.....	44
5.3.1 FCU7-DX670 / FCU7-DX671 / FCU7-DX770 / FCU7-DX771 .....	44
5.4 Keyboard Unit.....	45
5.4.1 FCU7-KB021 / FCU7-KB022 (ONG Layout).....	45
5.4.2 FCU7-KB041 (ABC Layout).....	46
5.5 Hard Disk Unit.....	47
5.5.1 FCU7-HD001 .....	47
5.5.2 Mounting on a Keyboard Unit .....	48
5.6 External Power Supply Unit.....	49
5.6.1 PD25.....	49
5.6.2 PD27.....	50
5.6.3 Mounting Direction and Clearance .....	50
5.7 Remote I/O Unit.....	51
5.7.1 FCUA-DX100 / FCUA-DX110 / FCUA-DX120 / FCUA-DX140 / FCUA-DX101 / FCUA-DX111 / FCUA-DX121 / FCUA-DX141 .....	51
5.8 Manual Pulse Generator.....	52
5.8.1 UFO-01-2Z9.....	52
5.8.2 HD60.....	53
5.9 Synchronous Feed Encoder .....	54
5.9.1 OSE-1024-3-15-68 .....	54
5.10 F Installation Plate .....	55
<b>6. Connections of Control Unit .....</b>	<b>56</b>
6.1 Control Unit Connection System Drawing .....	56
6.2 Connecting with Power Supply .....	57
6.2.1 When Using General-Purpose 24VDC Stabilized Power Supply.....	57
6.2.2 When Using PD25/PD27 Power Supply Unit.....	58
6.3 Connecting with Operation Panel I/O Unit .....	59
6.4 Connecting with Remote I/O Unit .....	60
6.5 Connecting with Scan I/O Card and Card-sized I/O Card .....	60
6.6 Connecting with Optical Communication Servo Drive Unit.....	61
6.7 Connecting with Auxiliary Axis Servo Drive Unit: MR-J2-CT .....	63
6.8 Connecting with Expansion Unit.....	64
6.8.1 Connecting with I/O Device Using PROFIBUS-DP .....	64
6.8.2 Expanding Optical Servo Communication I/F .....	65
6.8.3 Connecting I/O Devices via CC-Link .....	66
6.9 Connecting with RS-232C Device .....	68
6.10 Connecting with Skip Signal (Sensor) .....	70
6.11 Connecting with Synchronous Feed Encoder/Manual Pulse Generator .....	72
6.12 Connections of Emergency Stop Signal .....	73
6.13 Connecting with Safety Observing I/O Device: SDIO Connector .....	75

<b>7. Connections of Operation Panel I/O Unit.....</b>	<b>78</b>
7.1 Operation Panel I/O Unit Connection System Drawing .....	79
7.2 Connecting with Power Supply .....	80
7.3 Connecting with Display Unit.....	81
7.4 Connecting with Keyboard Unit .....	82
7.5 Connections of Emergency Stop Signal .....	83
7.6 Connecting with Manual Pulse Generator .....	85
7.6.1 Connecting with 12V Manual Pulse Generator (Maximum Cable Length: 50m) .....	85
7.6.2 Connecting with 5V Manual Pulse Generator (Maximum Cable Length: 20m) .....	86
7.7. Connecting with Remote I/O Unit .....	87
7.8. Connecting with Scan I/O Card and Card-sized I/O Card .....	87
7.9 Connecting with Machine Operation Panel.....	88
7.9.1 Wiring the Input Side DI Connector (CG31/CG33) .....	88
7.9.2 Wiring the Output Side DO Connector (CG32/CG34) .....	88
7.9.3 Outline of Digital Signal Input Circuit .....	89
7.9.4 Outline of Digital Signal Output Circuit .....	91
7.9.5 Wiring for Sink Type Output (FCU7-DX670/DX770).....	92
7.9.6 Wiring for Source Type Output (FCU7-DX671/DX771).....	93
<b>8. Connections of I/O Interface .....</b>	<b>94</b>
8.1 Types of I/O Interface .....	94
8.2 Connecting with Remote I/O Unit .....	95
8.2.1 Outline of Remote I/O Unit.....	95
8.2.2 Names of Each Remote I/O Unit Section .....	96
8.2.3 Setting of Station No. When Using Multiple Remote I/O Units.....	97
8.2.4 Outline of Digital Signal Input Circuit .....	99
8.2.5 Outline of Digital Signal Output Circuit .....	101
8.2.6 Outline of Analog Signal Output Circuit .....	102
8.2.7 Outline of Analog Signal Input Circuit .....	103
8.2.8 Connection of FCUA-DX10 □ /14 □ Unit and Machine Control Signal.....	104
8.2.9 Connection of FCUA-DX14 □ Unit and Analog Input/Output Signal.....	106
8.2.10 Connection of FCUA-DX11 □ Unit and Machine Control Signal.....	107
8.2.11 Connection of FCUA-DX12 □ Unit and Machine Control Signal.....	109
8.2.12 Cables.....	111
8.3 Connecting with Scan I/O Card .....	112
8.3.1 Outline .....	112
8.3.2 Hardware Interface .....	113
8.3.3 Connections.....	117
8.4 Connecting with Card-sized I/O Card .....	122
8.4.1 Connection Example.....	122
8.4.2 DI/DO Type Specifications .....	123
8.4.3 AI/AO Type Specifications.....	128
8.4.4 Precautions for Wiring .....	131
8.5 Connecting with Expansion I/O Card QY231 .....	133
8.5.1 Outline .....	133
8.5.2 Hardware Interface .....	133
8.5.3 Connections.....	136
<b>9. Connections of Display Unit .....</b>	<b>141</b>
9.1 Display Unit Connection System Drawing .....	141
9.1.1 FCU7-DA201-11 / FCU7-DA211-11 .....	141
9.1.2 FCU7-DA315-11 / FCU7-DA415-11 / FCU7-DA445-11 .....	142
9.2 Connecting with Power Supply .....	143
9.2.1 FCU7-DA201-11 / FCU7-DA211-11	
(When using general-purpose 24VDC stabilized power supply) .....	144
9.2.2 FCU7-DA201-11 / FCU7-DA211-11 (When using PD25/PD27 power supply unit).....	145

9.2.3 FCU7-DA315-11 / FCU7-DA415-11 / FCU7-DA445-11 (Connections of PD25/PD27 power supply unit) .....	146
9.3 Connecting with Operation Panel I/O Unit .....	147
9.4 Connecting with Keyboard Unit .....	147
9.5 Connecting with Front IC Card I/F Unit.....	148
9.6 Connecting with Hard Disk Unit: FCU7-DA315-11 / FCU7-DA415-11 / FCU7-DA445-11.....	149
9.7 Connecting with Floppy Disk Unit: FCU7-DA315-11 / FCU7-DA415-11 / FCU7-DA445-11....	150
<b>10. Basic Wiring for Servo Drive Unit.....</b>	<b>152</b>
10.1 Basic Wiring for MDS-D/DH Series .....	152
10.2 Basic Wiring for MDS-D-SVJ3/SPJ3 Series .....	153
<b>11. Turning the Power ON/OFF .....</b>	<b>154</b>
<b>Appendix 1. EMC Installation Guidelines .....</b>	<b>156</b>
1.1 Introduction.....	156
1.2 EMC Directives .....	156
1.3 EMC Measures .....	157
1.4 Panel Structure .....	157
1.4.1 Measures for Control Panel Body.....	157
1.4.2 Measures for Door .....	158
1.4.3 Measures for Power Supply.....	158
1.5 Measures for Wiring in Panel.....	159
1.5.1 Precautions for Wiring in Panel .....	159
1.5.2 Shield Treatment of Cables .....	160
1.6 EMC Countermeasure Parts.....	161
1.6.1 Shield Clamp Fitting.....	161
1.6.2 Ferrite Core.....	161
1.6.3 Surge Absorber .....	163
1.6.4 Selection of Stabilized Power Supply .....	165
<b>Appendix 2. Cable.....</b>	<b>166</b>
2.1 G014 Cable.....	168
2.2 G015 Cable.....	168
2.3 F020/F021/F022 Cable.....	169
2.4 G020/G021/G022 Cable .....	170
2.5 G023/G024 Cable .....	170
2.6 FCUA-R030 Cable.....	171
2.7 FCUA-R031 Cable.....	172
2.8 G031/G032 Cable.....	173
2.9 F034/F035 Cable .....	174
2.10 FCUA-R050/R054 Cable .....	175
2.11 F070 Cable .....	176
2.12 F110 Cable .....	176
2.13 F120 Cable .....	177
2.14 G123 Cable.....	177
2.15 F130 Cable .....	178
2.16 F140 Cable .....	179
2.17 G170 Cable.....	180
2.18 G171 Cable.....	180
2.19 F170 Cable .....	181
2.20 FCUA-R211 Cable .....	181
2.21 G291 Cable.....	182
2.22 G300 Cable.....	183
2.23 G301 Cable.....	183
2.24 R300 Cable.....	184
2.25 R301 Cable.....	184



2.26 G310 Cable.....	185
2.27 G380 Cable.....	185
2.28 G395 Cable.....	186
2.29 G396 Cable.....	186
2.30 G430 Cable.....	187
2.31 SH21 Cable .....	188
2.32 SH41 Cable .....	188
2.33 E-TM Terminator Connector .....	189
2.34 R-TM Terminator Connector .....	189
<b>Appendix 3. Connectors.....</b>	<b>190</b>
3.1 Connectors for Control Unit .....	190
3.1.1 Operation Panel I/O Unit Connecting Connector (OPI) .....	190
3.1.2 Auxiliary Axis Servo Drive Unit Connecting Connector (SV1).....	190
3.1.3 Auxiliary Axis Servo Drive Unit Connecting Connector (SV2).....	191
3.1.4 Skip Input Connector (SKIP).....	191
3.1.5 Serial Communication Connector (SIO) .....	192
3.1.6 Encoder / Manual Pulse Generator Connecting Connector (ENC).....	192
3.1.7 Optical Communication Connecting Connector (OPT1) .....	192
3.1.8 Remote I/O Unit Connecting Connector (RI01) .....	193
3.1.9 Remote I/O Unit Connecting Connector (RI02) .....	193
3.1.10 Emergency Stop Input Connector (EMGIN).....	193
3.1.11 Power OFF Input Connector (CFO1) .....	194
3.1.12 24VDC Input Connector (DCIN) .....	194
3.1.13 Ethernet Connector (LAN) .....	194
3.1.14 DIO Input/Output Connector (SDIO).....	195
3.2 Connectors for Operation Panel I/O Unit .....	196
3.2.1 Manual Pulse Generator Connecting Connector (MPG) .....	196
3.2.2 24VDC Input Connector (DCIN) .....	196
3.2.3 Remote I/O Unit Connecting Connector (RIO3) .....	196
3.2.4 Machine Input/Output Connector (CG31/CG32/CG33/CG34).....	197
3.2.5 Reset Switch Input Connector (NCRST) .....	198
3.2.6 Emergency Stop Input Connector (EMGIN).....	198
3.2.7 Ethernet Connector (LAN) .....	199
3.2.8 24VDC Input Connector (DCIN) .....	199
3.3 Connectors for Display Unit .....	200
3.3.1 Ethernet Connector (LAN) .....	200
3.3.2 ON/OFF Switch Connector (ON/OFF) .....	200
3.3.3 USB Connector (USB1, USB2).....	200
3.3.4 Remote ON/OFF Connector (CF24).....	201
3.3.5 Emergency Stop Input Connector (EMGIN).....	201
3.3.6 Power OFF Input Connector (CFO1).....	201
3.3.7 24VDC Input Connector (DCIN) .....	202
3.3.8 Serial Communication Connector (SIOPC) .....	202
3.4 Connectors for Power Supply Unit.....	203
3.4.1 24VDC Output Connector (DCOUT).....	203
3.4.2 AC Power Input Connector (ACIN) .....	203
3.4.3 ON/OFF Input Connector (ON/OFF).....	203
<b>Appendix 4. Servo/Spindle Cable and Connector Specifications (MDS-D/DH Series) .....</b>	<b>204</b>
4.1 Selection of Cable.....	204
4.1.1 Cable Wire and Assembly.....	204
4.2 Cable Connection Diagram.....	206
4.2.1 Battery Cable .....	206
4.2.2 Power Supply Communication Cable and Connector.....	207
4.2.3 Servo Detector Cable .....	208

4.2.4 Brake Connector (Brake Connector for Motor Brake Control Output) .....	212
4.2.5 Spindle Detector Cable .....	213
4.2.6 C axis Detector Cable (For Serial Interface Conversion Unit APE391M Connection) .....	215
4.3 Main Circuit Cable Connection Diagram.....	216
4.3.1 DRSV1 cable, DRSV2 cable.....	216
4.4 Connector Outline Dimension Drawings.....	217
4.4.1 Optical Communication Cable .....	217
4.4.2 Battery Connector.....	219
4.4.3 Power Supply Communication Connector .....	220
4.4.4 Servo Detector Connector .....	221
4.4.5 Brake Connector.....	224
4.4.6 Power Connector.....	225
4.4.7 Spindle Detector Connector.....	227
<b>Appendix 5. Servo/Spindle Cable and Connector Specifications</b> <b>(MDS-D-SVJ3/SPJ3 Series) .....</b>	<b>229</b>
5.1 Selection of Cable.....	229
5.1.1 Cable Wire and Assembly.....	229
5.2 Cable Connection Diagram.....	231
5.2.1 Servo Detector Cable .....	231
5.2.2 Spindle Detector Cable .....	234
5.2.3 C Axis Detector Cable (For Serial Interface Conversion Unit APE391M Connection).....	236
5.3 Connector Outline Dimension Drawings.....	237
5.3.1 Optical Communication Cable .....	237
5.3.2 Servo Detector Connector .....	239
5.3.3 Brake Connector.....	241
5.3.4 Power Connector.....	242
5.3.5 Drive Unit Side Main Circuit Connector .....	243
5.3.6 Spindle Detector Connector.....	245
<b>Appendix 6. Precautions for Wiring M700 Series .....</b>	<b>247</b>
6.1 Connecting the Optical Fiber Cable.....	247
6.1.1 Outline of Optical Fiber Cable and Names of Each Part .....	247
6.1.2 Precautions for Handling Optical Fiber Cable.....	247
6.1.3 Precautions for Laying Optical Fiber Cable .....	248
6.2 Precautions for Connecting Peripheral Devices .....	248
6.3 Precautions for Connecting 24V Power Supply.....	248
6.4 Connection Example When Not Using Operation Panel I/O Unit .....	249
6.5 Ferrite Core Installation Method .....	251
6.6 Example of Handy Terminal Connections.....	252
6.6.1 Environment Specifications for Handy Terminal .....	252
6.6.2 Outline Drawing of Handy Terminal .....	253
6.6.3 Connections of Handy Terminal.....	255
6.6.4 Explanation of Handy Terminal Signals and Connection Cables .....	256
<b>Appendix 7. Transportation Restrictions for Lithium Batteries.....</b>	<b>259</b>
7.1 Restriction for Packing.....	259
7.1.1 Target Products.....	260
7.1.2 Handling by User .....	261
7.1.3 Reference .....	262
7.2 Issuing Domestic Law of the United States for Primary Lithium Battery Transportation .....	263
7.2.1 Outline of regulation.....	263
7.2.2 Target products .....	263
7.2.3 Handling by user.....	263
7.2.4 Reference .....	264
7.3 Example of Hazardous Goods Declaration List.....	265

**Appendix 8. Precautions for Use of Peripheral Devices and Commercially Available  
Devices..... 267**

**Appendix 9. Precautions for Use of Peripheral Devices and Commercially Available Devices  
..... 268**

### 1. Introduction

This manual explains the items required for installing and connecting the MITSUBISHI CNC 700 Series. Read this manual thoroughly and understand the product's functions and performance before starting to use. This manual is written on the assumption that all option functions are added, but the actually delivered device may not have all functions.

The unit names, cable names and various specifications are subject to change without notice. Please confirm these before placing an order.

## 2. System Configuration

### 2.1 System Basic Configuration Drawing

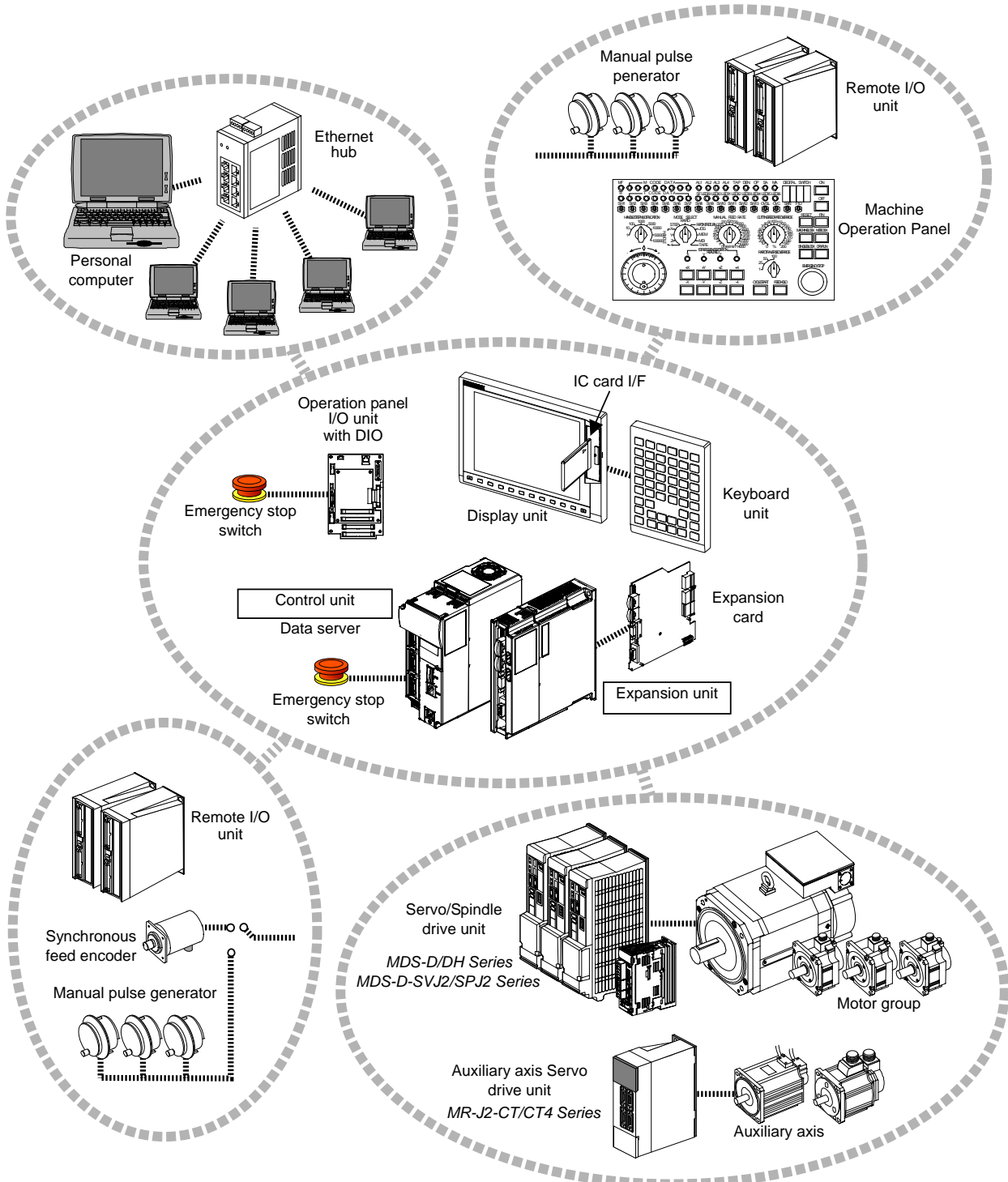

2.2 General Connection Diagram

2.2.1 Display Unit: FCU7-DA201-11/FCU7-DA211-11

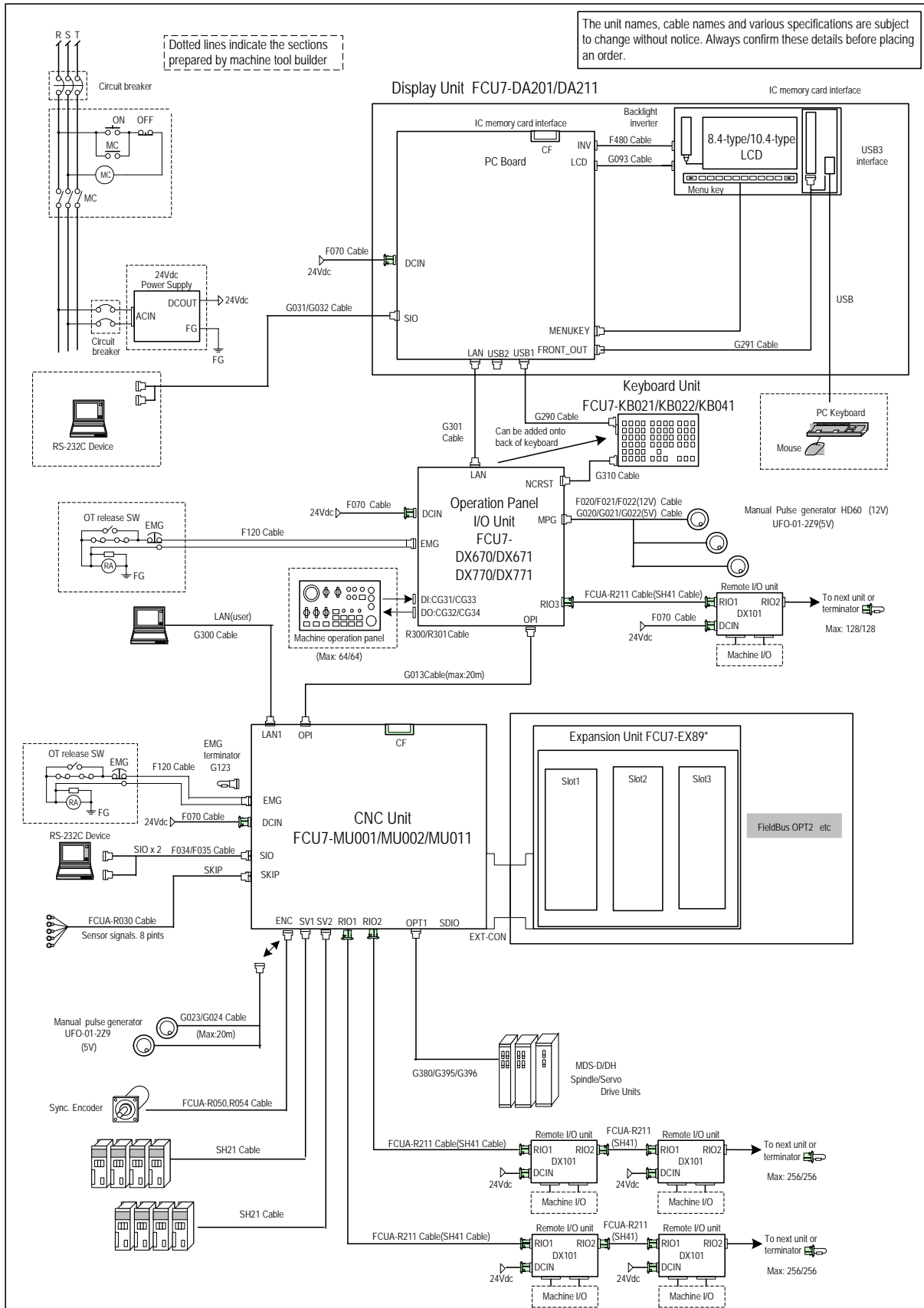

## 2. System Configuration

### 2.2 General Connection Diagram

#### 2.2.2 Display Unit:

#### FCU7-DA315-11/FCU7-DA415-11/FCU7-DA445-11/FCU7-DA335-11/FCU7-DA435-11

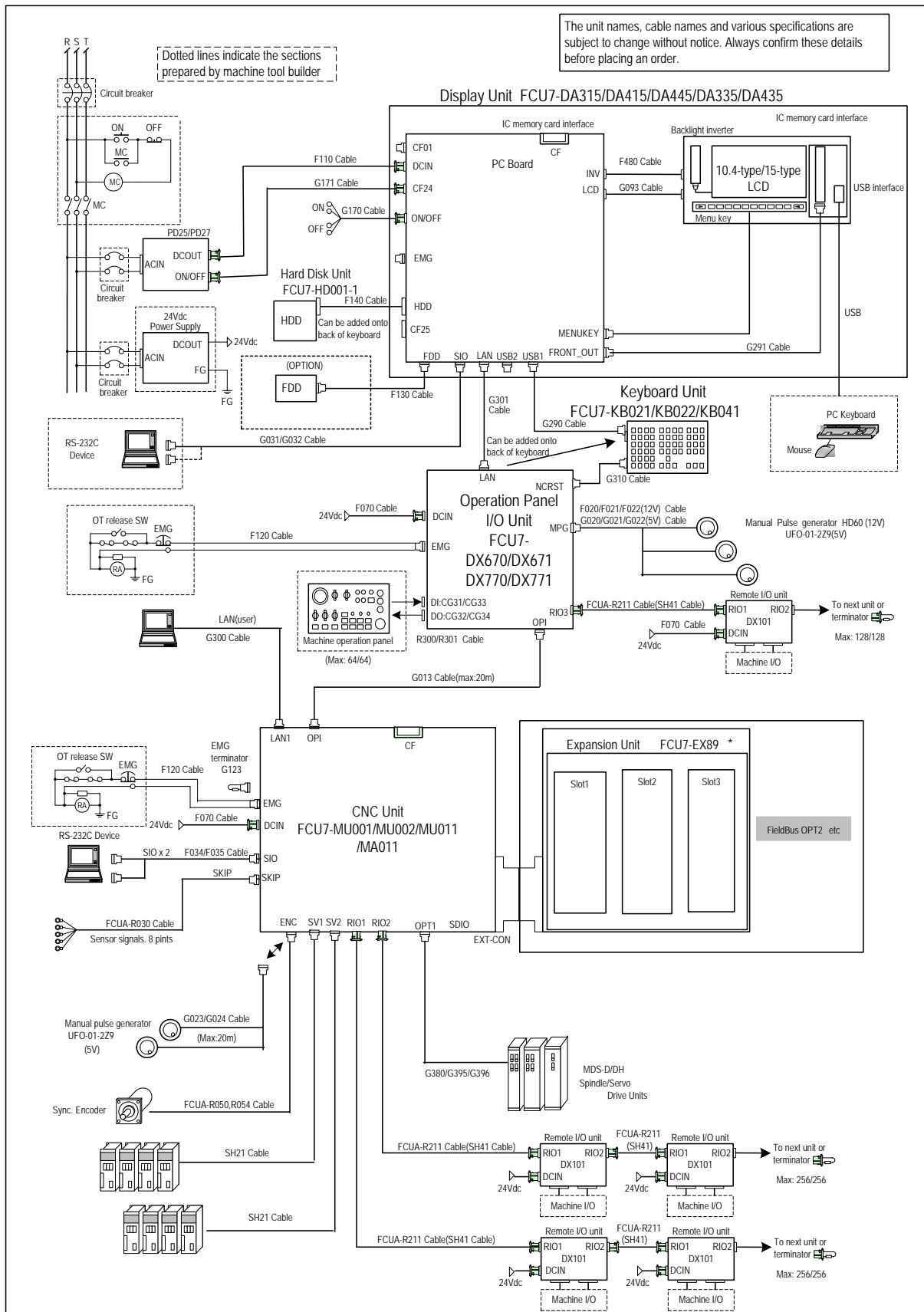

## 2.3 List of Configuration Units

## 2.3.1 Control Unit: FCU7-MU001/FCU7-MU002/FCU7-MU011/FCU7-MA011

Type	Function	Configuration element	Details
FCU7-MU001	M700 control unit set  M720 system compatible unit	Main control card (HN115) CPU card (HN122) Display/setting card (HN091)  24V input power supply card (HN081) Memory card (HN482) G123 cable Case set	Export Trade Control Ordinance and Foreign Trade Ordinance noncompliant unit
FCU7-MU002	M700 control unit set  M720 system compatible unit	Main control card (HN116) (CPU card section is within HN116.) Display/setting card (HN091)  24V input power supply card (HN081) Memory card (HN482) G123 cable Case set	Export Trade Control Ordinance and Foreign Trade Ordinance noncompliant unit
FCU7-MU011	M700 control unit set  M730 system compatible unit	Main control card (HN115) CPU card (HN123) Display/setting card (HN091)  24V input power supply card (HN081) Memory card (HN484) G123 cable Case set	Export Trade Control Ordinance and Foreign Trade Ordinance noncompliant unit
FCU7-MA011	M700 control unit set  M750 system compatible unit	Main control card (HN145) CPU card (HN123) Display/setting card (HN091)  24V input power supply card (HN081) Memory card (HN484) G123 cable Case set	Export Trade Control Ordinance and Foreign Trade Ordinance compliant unit



## 2. System Configuration

### 2.3 List of Configuration Units

#### 2.3.2 Display Unit:

#### FCU7-DA201/FCU7-DA211/FCU7-DA315/FCU7-DA415/FCU7-DA445/FCU7-DA335/FCU7-DA435

Type	Function	Configuration element	Details
FCU7-DA201-xx	8.4-type color LCD display unit WindowsCE compatible (separated type)	8.4-type (VGA) LCD, Escutcheon Control card (ROD-6204-MIT1CE) G093 cable G291 cable F480 cable with front IC card (FCU7-EP102)	Control card 24VDC input Mounting method: Mount on front panel
FCU7-DA211-xx	10.4-type color LCD display unit WindowsCE compatible (separated type)	10.4-type (VGA) LCD, Escutcheon Control card (ROD-6204-MIT1CE) G093 cable G291 cable F480 cable with front IC card (FCU7-EP102)	Control card 24VDC input Mounting method: Mount on front panel
FCU7-DA315-xx	10.4-type color LCD display unit WindowsXPe compatible (separated type)	10.4-type (VGA) LCD, Escutcheon Control card (MIC73M2) G093 cable G291 cable F480 cable with front IC card (FCU7-EP102)	Celeron 733MHz Control card: 24VDC input Mounting method: Mount on front panel Use PD25/PD27 for power supply
FCU7-DA415-xx	10.4-type color LCD display unit High-performance version WindowsXPe compatible (separated type)	10.4-type (VGA) LCD, Escutcheon Control card (MIP12M2) G093 cable G291 cable F480 cable with front IC card (FCU7-EP102)	Pentium III 1.26GHz Control card: 24VDC input Mounting method: Mount on front panel Use PD25/PD27 for power supply
FCU7-DA445-xx	10.4-type color LCD display unit (Wide view angle) High-performance version WindowsXPe compatible (separated type)	10.4-type (VGA) LCD, Escutcheon Control card (MIP12M2) G093 cable G291 cable F480 cable with front IC card (FCU7-EP102)	Pentium III 1.26GHz Control card: 24VDC input Mounting method: Mount on front panel Use PD25/PD27 for power supply
FCU7-DA335-xx	15-type color LCD display unit WindowsXPe compatible (separated type)	15-type (XGA)LCD, Escutcheon Control card (MIC73M2) with front IC card (FCU7-EP102)	Celeron733MHz Control card: 24VDC input Mounting method: Mount on front panel Use PD25/PD27 for power supply
FCU7-DA435-xx	15-type color LCD display unit High-performance version WindowsXPe compatible (separated type)	15-type (XGA)LCD, Escutcheon Control card (MIC73M2) with front IC card (FCU7-EP102)	Pentium III 1.26GHz Control card: 24VDC input Mounting method: Mount on front panel Use PD25/PD27 for power supply

**(Note 1)** FCU7-DAxxx-01: without MITSUBISHI logo; without touch panel; with menu key  
 FCU7-DAxxx-11: with MITSUBISHI logo; without touch panel; with menu key  
 FCU7-DAxxx-21: without MITSUBISHI logo; with touch panel; with menu key  
 FCU7-DAxxx-31: with MITSUBISHI logo; with touch panel; with menu key  
 (FCU7-DA201-xx: without touch panel type only)  
 FCU7-DAxxx-61: without MITSUBISHI logo; with touch panel: without menu key  
 FCU7-DAxxx-71: with MITSUBISHI logo; with touch panel: without menu key

**(Note 2)** OS and S/W are not included for the types of display units listed above.

2.3.3 Operation Panel I/O Unit: FCU7-DX670/FCU7-DX671/FCU7-DX770/FCU7-DX771

Type	Function	Configuration element	Details
FCU7-DX670	Sink/source input + sink output	HN391  Mounting bracket G301 cable G310 cable Terminator R-TM	DI/DO = 32 points/32 points (output 60mA) Output insulation type (Note 1) Display-main body relay I/F Manual pulse generator 3ch Emergency stop input Remote I/O 1ch (160 points/160 points)
FCU7-DX671	Sink/source input + source output	HN392  Mounting bracket G301 cable G310 cable Terminator R-TM	DI/DO = 32 points/32 points (output 60mA) Output insulation type (Note 1) Display-main body relay I/F Manual pulse generator 3ch Emergency stop input Remote I/O 1ch (160 points/160 points)
FCU7-DX770	Sink/source input + sink output	HN391+HN396  Mounting bracket G301 cable G310 cable Terminator R-TM	DI/DO = 64 points/64 points (output 60mA) Output insulation type (Note 1) Display-main body relay I/F Manual pulse generator 3ch Emergency stop input Remote I/O 1ch (128 points/128 points)
FCU7-DX771	Sink/source input + source output	HN392+HN397  Mounting bracket G301 cable G310 cable Terminator R-TM	DI/DO = 64 points/64 points (output 60mA) Output insulation type (Note 1) Display-main body relay I/F Manual pulse generator 3ch Emergency stop input Remote I/O 1ch (128 points/128 points)

**(Note 1)** All points of the DO are insulated with a photo coupler. Thus, 24V must be input from an external source for the DO output. Refer to "7.9 Connecting with Machine Operation Panel" for details.

**(Note 2)** Operation panel I/O unit can be mounted on the back side of the keyboard unit FCU7-KB021/KB022/KB041.

2.3.4 Keyboard Unit : FCU7-KB021/FCU7-KB022/FCU7-KB041

Type	Function	Configuration element	Details
FCU7-KB021	8.4-type display keyboard	Escutcheon, key switch	Connect with G290 cable from display unit.
	ONG layout for machining center	Control card, G290 cable	Mounting method: Mount on front panel
FCU7-KB022	8.4-type display keyboard	Escutcheon, key switch	Connect with G290 cable from display unit.
	ONG layout for lathe	Control card, G290 cable	Mounting method: Mount on front panel
FCU7-KB041	10.4-type display keyboard	Escutcheon, key switch	Connect with G290 cable from display unit.
	ABC layout	Control card, G290 cable	Mounting method: Mount on front panel

## 2. System Configuration

### 2.3 List of Configuration Units

#### 2.3.5 Remote I/O Unit: FCUA-DX100/DX110/DX120/DX140/DX101/DX111/DX121/DX141

Type	Function	Configuration element	Details
FCUA-DX100	Sink/source input + sink output	RX311	DI/DO = 32 points/32 points
FCUA-DX110	Sink/source input + sink output	RX311+RX321-1	DI/DO = 64 points/48 points
FCUA-DX120	Sink/source input + sink output + analog output	RX311+RX321	DI/DO = 64 points/48 points + analog output 1 point
FCUA-DX140	Sink/source input + sink output + analog input/output	RX311+RX341	DI/DO = 32 points/32 points + analog input 4 points + analog output 1 point
FCUA-DX101	Sink/source input + source output	RX312	DI/DO = 32 points/32 points
FCUA-DX111	Sink/source input + source output	RX312+RX322-1	DI/DO = 64 points/48 points
FCUA-DX121	Sink/source input + source output + analog output	RX312+RX322	DI/DO = 64 points/48 points + analog output 1 point
FCUA-DX141	Sink/source input + source output + analog input/output	RX312+RX341	DI/DO = 32 points/32 points + analog input 4 points + analog output 1 point

#### 2.3.6 Scan I/O: HR357/HR347

Type	Function	Configuration element	Details
HR357	Scan I/O (source)	HR357	Scan DI/DO = 64 points/64 points DI/DO = 32 points/32 points
HR347	Scan I/O (sink)	HR347	Scan DI/DO = 64 points/64 points DI/DO = 32 points/32 points

#### 2.3.7 Card-sized I/O Card: HR361/HR371/HR381/HR383

Type	Function	Configuration element	Details
HR361	DI16 (sink/source) +DO16 (sink)	HR361	DI/DO = 16 points/16 points
HR371	DI32 (sink/source) +DO16 (source)	HR371	DI/DO = 16 points/16 points
HR381	AO x 1	HR381	AO x 1
HR383	AI x 4+AO x 1	HR383	AI x 4+AO x 1

2.3.8 Extended I/O Card: QY231

Type	Function	Configuration element	Details
QY231	Sink/source input + source output	QY231	Sink/source input 64 points + source output 48 points

2.3.9 Front IC Card Interface: FCU7-EP102-1 (option)

Type	Function	Configuration element	Details
FCU7-EP102-1	Memory card slot x 1ch USB x 1ch (Ver1.1, Series "A" Connectors)	Front IC card I/F (USB-PC-CARD-TYPE-A)	Connect with G291 cable from display unit. PC Card Standard ATA compliant memory card TYPEI, TYPEII only 5VDC: max 220mA USB(Ver1.1)I/F (5VDC, max 100mA)

2.3.10 Hard Disk Unit: FCU7-HD001-1

Type	Function	Configuration element	Details
FCU7-HD001-1	External memory device	Hard disk Mounting plate, cushioning rubber F140 cable (50cm)	Display unit Connect with FCU7-DA315/DA415/DA445. Installation method: Mount on the back of FCU7-KB041 ( <b>Note 1</b> )

**(Note 1)** When not mounting the hard disk unit onto the back of the FCU7-KB041, face the cable lead-out side vertically to a side with no vibration, and mount within  $\pm 15^\circ$ .

**(Note 2)** OS and S/W are not included for the types of display units listed above.

2.3.11 Floppy Disk Unit: FCU7-FD221

Type	Function	Configuration element	Details
FCU7-FD221-1	External memory device	Floppy disk drive Mounting plate for pendant box F130 cable (1m)	Display unit Connect with FCU7-DA315/DA415/DA445

#### 2.3.12 Expansion Unit: FCU7-EX891

Type	Function	Configuration element	Details
FCU7-EX891	Expansion unit x 1slot	HR891 Mounting plate, case set	One expansion card HN5xx can be mounted additionally. Installation method: Mount on the side of NC unit

**(Note1)** Only one expansion unit can be mounted.

#### 2.3.13 Expansion Card

Type	Function	Configuration element	Details
FCU7-HN551	Optical servo communication I/F × 1ch	HN551	Expansion unit Connect with FCU7-EX891. Installation method: Insert in expansion unit and fix with front cover
FCU7-HN552	Optical servo communication I/F × 2ch	HN552	
FCU7-HN571	PROFIBUS-DP × 1ch	HN571	
FCU7-HN576	CC-Link × 1ch	HN576	

#### 2.3.14 External Power Supply Unit: PD25/PD27

Type	Function	Configuration element	Details
PD25	External power supply with power supply ON/OFF function	Power supply card Case set	Input 200VAC Output 24VDC (3A)
PD27	External power supply with power supply ON/OFF function	Power supply card Case set	Input 200V to 400VAC Output 24VDC (8A)

### 3. General Specifications (Environment Conditions)

#### 3.1 Environment Conditions in Operation Box

### 3. General Specifications (Environment Conditions)

#### 3.1 Environment Conditions in Operation Box

Item	Unit name		Display unit (Note 5) (Including keyboard and front IC card I/F unit)					Operation panel I/O unit		
	Type		FCU7 -DA201	FCU7 -DA211	FCU7 -DA315	FCU7 -DA415/ DA445	FCU7 -DA335	FCU7 -DA435	FCU7 -DX670/ DX671	FCU7 -DX770/ DX771
General specifications	Ambient temperature	During operation	0 to 55°C (Note 1)							
		During storage	-20 to 60°C							
	Ambient humidity	Long term	10 to 75% RH (with no dew condensation)							
		Short term	10 to 95% RH (with no dew condensation) (Note 2)							
	Vibration resistance	During operation	4.9m/s <sup>2</sup> [0.5G] or less							
	Shock resistance	During storage	29.4m/s <sup>2</sup> [3.0G] or less							
	Working atmosphere		No corrosive gases, dust or oil mist							
Required power specifications	Power voltage		24VDC ± 5%, ripple noise 240mV (P-P)							
	Power capacity	(max.)	2A (max.)	2.5A (max.)	3A (max.)	2.8A (max)	3.3A (max)	0.5A (Note 3) 2.9A (Max.) (Note 4)	0.7A (Note 3) 5.0A (max.) (Note 4)	
	Instantaneous stop tolerance time		AC: 20ms or less (when using external power supply unit PD25/PD27), 24VDC: 2ms or less							
Others	Heating value		25W (max.) 15W (Typ)	46W (max.) 37W (Typ)	60W (max.) 48W (Typ)	53.5W (max) 43W (Typ)	67.5W (max) 54W (Typ)	30W (max.) (Note 4)	50W (max.) (Note 4)	
	Mass	Display	3.5 kg	4.0 kg			6kg		0.6 kg	
Others	Keyboard unit FCU7-KB021/KB022 : 1.0 kg FCU7-KB041 : 1.5 kg Front IC card I/F unit FCU7-EP102-1 : 0.3 kg Hard disk unit FCU7-HD001-1 : 0.6kg									

**(Note 1)** The display grade (contrast/brightness) will drop at 45°C or more.

**(Note 2)** The period is within one month.

**(Note 3)** Current consumed by control circuit section.

**(Note 4)** Differs according to the number of machine input operation points and the load and number of points connected to the machine output. The maximum value applies when all points are ON.

**(Note 5)** Panel front is equivalent to IP65F.

### 3. General Specifications (Environment Conditions)

#### 3.2 Environment Specifications in Electric Cabinet

#### 3.2 Environment Specifications in Electric Cabinet

Item	Unit name		Control unit	Expansion unit	External power supply unit	
	Type		FCU7- MU001/MU002/MU011/MA011	FCU7-EX891	PD25	PD27
General specifications	Ambient temperature	During operation	0 to 55°C			
		During storage	-20 to 60°C			
	Ambient humidity	Long term	10 to 75% RH (with no dew condensation)			
		Short term	10 to 95% RH (with no dew condensation) (Note 1)			
	Vibration resistance	During operation	4.9m/s <sup>2</sup> [0.5G] or less			
	Shock resistance	During storage	29.4m/s <sup>2</sup> [3.0G] or less			
	Working atmosphere		No corrosive gases, dust or oil mist			
Required power specifications	Input power voltage		24VDC ± 5% Ripple noise 240mV (P-P)	200V to 230VAC +10%-15%, 50/60Hz ± 1Hz	200V to 480VAC +10%-15%, 50/60Hz ± 3Hz	
	Power capacity	(max.)	3A (max) (control unit: 1.3A, expansion unit: 1.7A)	-	-	
	Input current	(max.)	—	1.0A (200VAC at rated load)	1.5A (240VAC at rated load) 0.76A (480VAC at rated load)	
	Output current	(max.)	—	3A	8A	
	Instantaneous stop tolerance time		AC: 20ms or less, 24VDC: 2ms or less			
Others	Heating value		27W (max) 15W(Typ)	34W (max) 17W(Typ)	35W (max)	58W (max)
	Mass		1.1kg	0.6kg	1.5kg	2kg

**(Note 1)** The period is within one month.

## 3.3 Remote I/O Unit

Item	Unit name		Remote I/O unit			
	Type		FCUA-DX10□	FCUA-DX11□	FCUA-DX12□	FCUA-DX14□
General specifications	Ambient temperature	During operation	0 to 55°C			
		During storage	-20 to 60°C			
	Ambient humidity	Long term	10 to 75% RH (with no dew condensation)			
		Short term	10 to 95% RH (with no dew condensation) <b>(Note 1)</b>			
	Vibration resistance		4.9m/s <sup>2</sup> or less (during operation)			
	Shock resistance		29.4m/s <sup>2</sup> or less (during operation)			
	Working atmosphere		No corrosive gases, dust			
Required Power specification	Input power voltage		24VDC±5% Ripple noise 200mV (P-P)			
	Power capacity		24V 0.7A <b>(Note 2)</b>	24V 1.5A <b>(Note 2)</b>	24V 0.7A <b>(Note 2)</b>	
	Instantaneous stop tolerance time		—			
Others	Heating value (Max.)		25W <b>(Note 3)</b>	30W <b>(Note 3)</b>	30W <b>(Note 3)</b>	
	Mass		0.5kg	0.6kg	0.6kg	0.6kg

**(Note 1)** The period is within one month.

**(Note 2)** Amount consumed by control circuit

**(Note 3)** Differs according to the number of machine input operation points and the load and number of points connected to the machine output. The maximum value applies when all points are ON.

## 3.4 Servo / Spindle

Refer to the following manuals for details on the servo and spindle system.

MDS-D Series	Specification Manual	(IB-1500011)
MDS-DH Series	Specification Manual	(IB-1500003)
MDS-D-SVJ3/SPJ3 Series	Specification Manual	(IB-1500158)



3.5 Heat Radiation Countermeasures

Please refer to the following method for heat radiation countermeasures.

Example of heat radiation countermeasures

<Hypothetical conditions>

- (1) Average internal temperature of operation panel:  $T \leq 55^{\circ}\text{C}$
- (2) Peripheral temperature of operation panel :  $T_a \leq 0^{\circ}\text{C to } 45^{\circ}\text{C}$
- (3) Internal temperature rise value :  $\Delta T = T - T_a (\text{max}) = 10^{\circ}\text{C}$

Procedures for heat design and verification

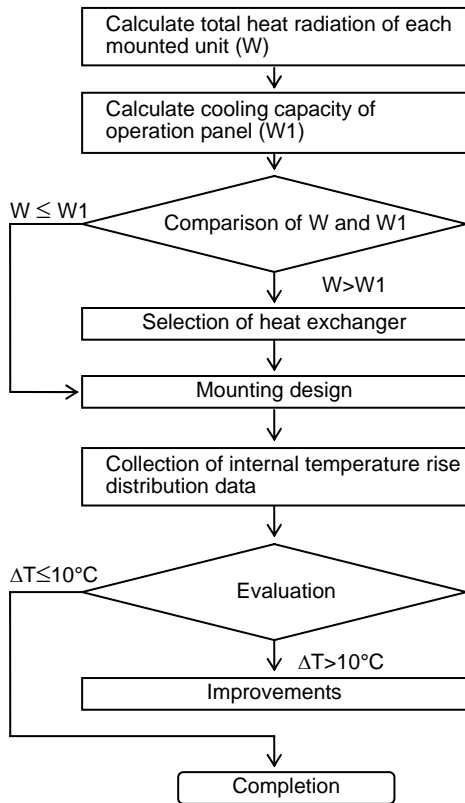

<Supplement>

(1) Refer to "3. General Specification" for the heat generated by each unit.

(2) Enclosed cabinet (thin steel plate) cooling capacity calculation equation

$$W1 = U \times A \times \Delta T$$

$$U: 6 \text{ W/m}^2\text{C}$$

A: Effective heat radiation area (m<sup>2</sup>)

ΔT: Internal temperature rise value (10°C)

(Area where heat can be radiated from operation panel)

<Caution>

8 W/m<sup>2</sup>C can be applied only when the operation panel is so small that the internal temperature stays uniform.

(3) Points of caution for heat radiation countermeasures when designing mounting state

\* Consider convection in operation panel (eliminate heat spots)

\* Collect hot air at suction port of heat exchanger in operation panel.

(4) Criterion for internal temperature rise distribution data

$$\Delta T (\text{average value}) \leq 10^{\circ}\text{C}$$

$$\Delta T_{\text{max}} (\text{maximum value}) \leq 15^{\circ}\text{C}$$

$$R (\text{inconsistency } \Delta T_{\text{max}} - \Delta T_{\text{min}}) \leq 6^{\circ}\text{C}$$

(Evaluate existence of heat spots)

### 3. General Specifications (Environment Conditions)

#### 3.5 Heat Radiation Countermeasures

The following shows an example of calculation applied to heat radiation countermeasures for the operation panel. Because heat will accumulate in the upper portions of the unit, install an agitating fan as required.

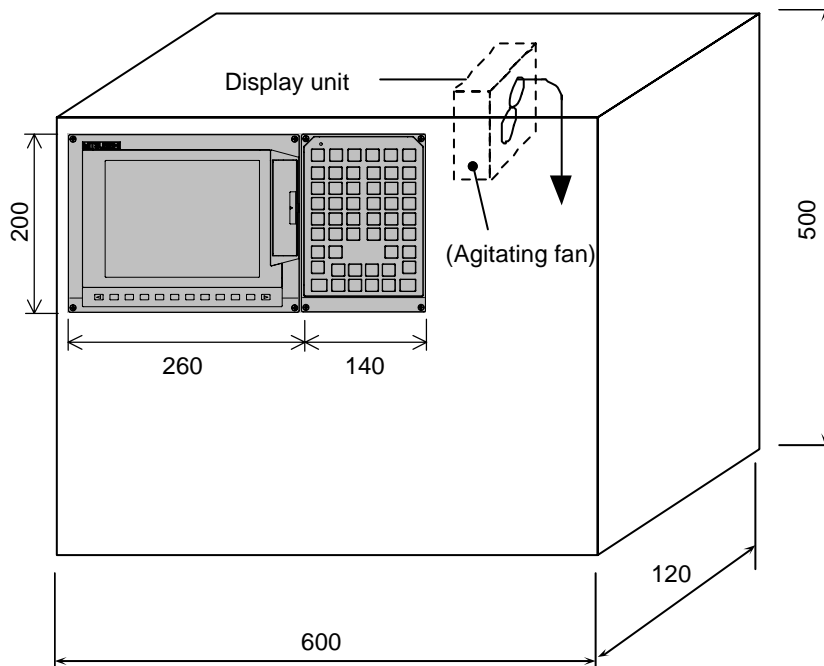

#### <Calculation example of heating value in operation panel>

(1) Calculation of unit heating value

Heating value (W)

Total heating value of units (W):

27W (= display unit + operation panel I/O unit)

Total heating value (W) by machine input (D1):

5.6W (= 24V; total heating value when the 32 points are simultaneously turned ON  $\times 7.3\text{mA} \times 32$ )

... 24V; current consumption per point of the operation panel I/O unit  $D1 \div 3.3\text{k}\Omega \doteq 7.3\text{mA}$

Total heating value W = 32.6W (27 + 5.6)

(2) Calculation of operation panel cooling capacity

Tolerance value for temperature rise ( $\Delta t$ )

Panel internal temperature (according to each unit's specification)  $T \leq 55\text{C}^\circ$

Panel peripheral temperature (according to machine's specification)  $T_a \leq 45\text{C}^\circ$

Tolerance value for internal temperature rise  $\Delta T = \boxed{10\text{C}^\circ}$  ( $T - T_a$ )

Heat radiation area (A)

The surface of the molded unit, which has lower radiation capacity than the metal plate surface, should be excluded for the heat radiation area in principle.

The bottom of the operation panel, which has difficulty in radiating due to the temperature distribution, should also be excluded for the heat radiation area in principle.

Heat radiation area  $A = \boxed{0.71\text{mm}^2}$

$$\left( \begin{array}{l} \doteq \\ \text{(Top surface)} \end{array} 0.6 \times 0.12 + \begin{array}{l} \doteq \\ \text{(Front, rear surface)} \end{array} 0.6 \times 0.5 \times 2 - \begin{array}{l} \doteq \\ \text{(Unit surface)} \end{array} (0.26 + 0.14) \times 0.2 + \begin{array}{l} \doteq \\ \text{(Both sides surface)} \end{array} 0.12 \times 0.5 \times 2 \right)$$

Operation panel cooling capacity (W1)

Calculate the cooling capacity to keep the temperature rise in the operation panel less than  $10\text{C}^\circ$ .

Cooling capacity  $W1 = \boxed{42.6\text{W}}$  ( $6 \times A \times \Delta T$ )

(3) Comparison of heating value and operation panel cooling capacity

The operation panel cooling capacity is over the heating value, which presumed no need to install the heat exchanger.

(4) Confirmation with the actual machine

The result of the calculation above is only a rough indication. The actual temperature rise may differ according to the structure of the operation panel.

Be sure to confirm the temperature rise value in the operation panel when the machine is running.

### 3.6 Noise Countermeasures

#### 3.6.1 Connection of FG (Frame Ground)

The frame should basically be grounded at one ground point.  
 Connect the control unit's 0V (RG) to the FG on the +24V stabilized power supply.

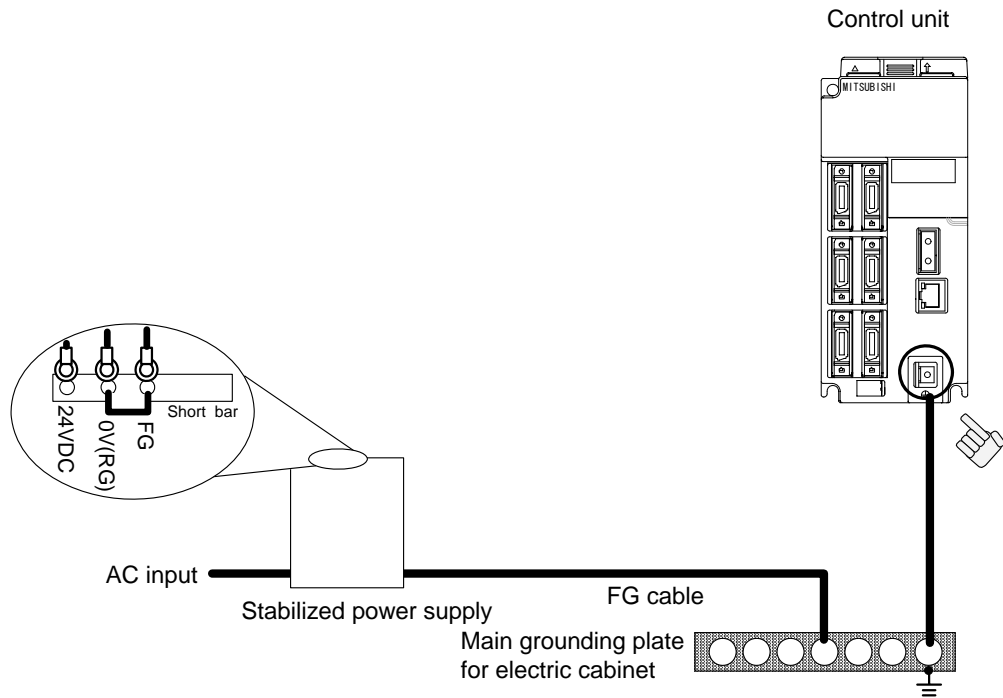

### 3.6.2 Shield Clamping of Cables

The shield cables connected to the units must be connected to the ground by using clamp fittings to stabilize the operation while preventing malfunctioning due to noise. (Refer to Appendix 1.6.1.)

### 3.6.3 Connecting Spark Killers

Connect a spark killer on the coil or the contact in parallel for noise countermeasures. Use spark killers which are 0.33 to 0.1  $\mu\text{F}$ , 10 to 120  $\Omega$ .

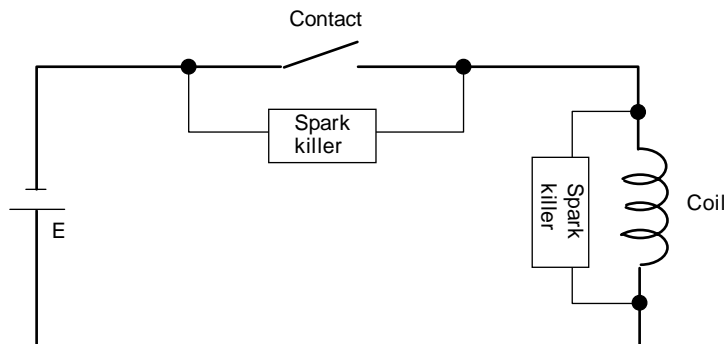

## 4. Outline Drawing

### 4.1 Control Unit

#### (1) Control unit only

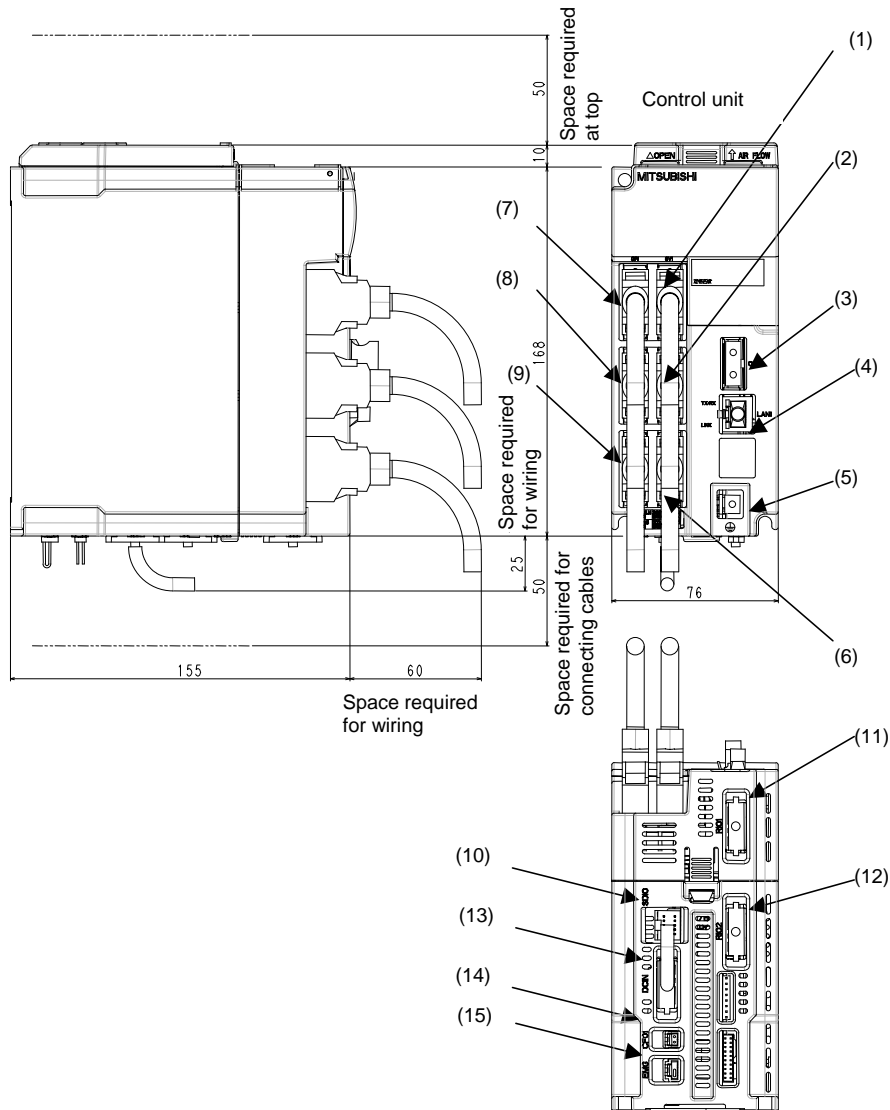

(2) With expansion unit

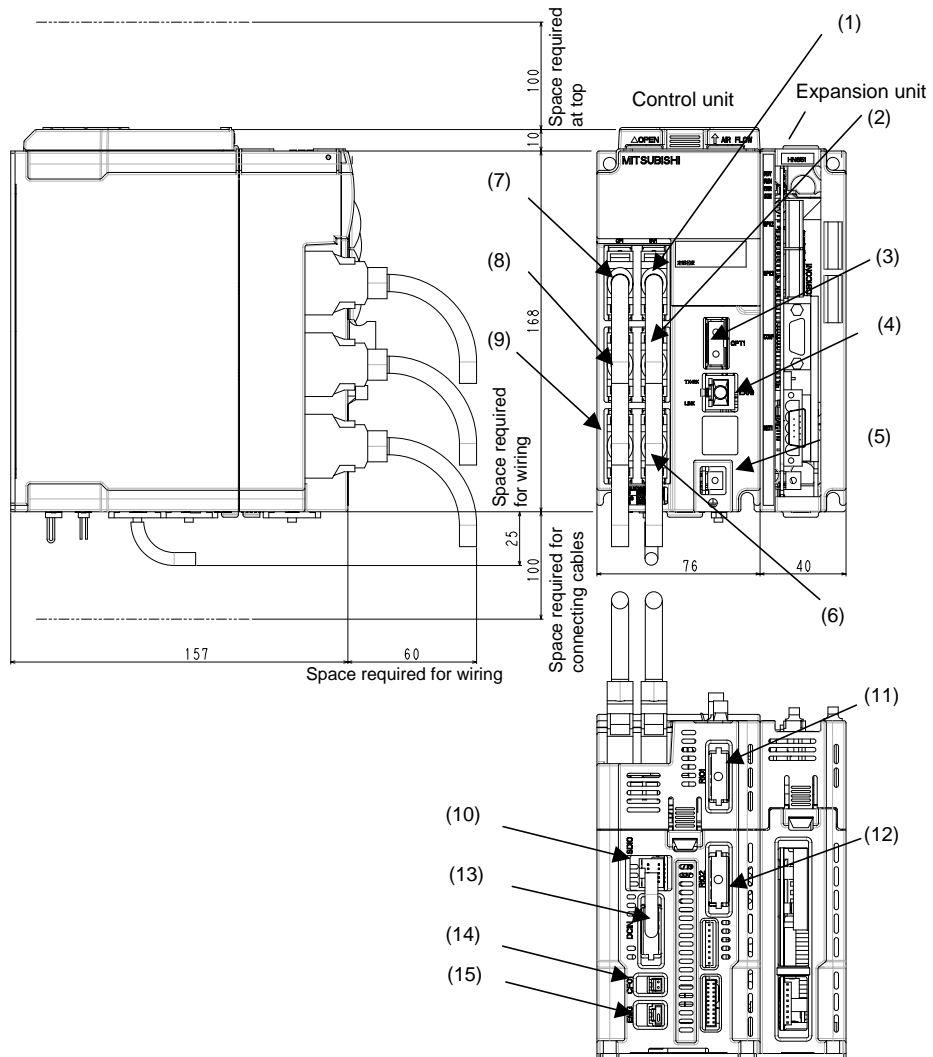

**(3) Explanation of control unit and connector functions**

No.	Connector name	Function	No.	Connector name	Function
(1)	SV1	Auxiliary axis servo communication I/F	(9)	ENC	Encoder input 1ch (5V manual pulse generator input 2ch)
(2)	SV2	Auxiliary axis servo communication I/F	(10)	SDIO	Input/output I/F for safety monitoring
(3)	OPT1	Optical servo communication I/F	(11)	RIO1	Remote IO unit I/F
(4)	LAN1	NC LAN communication I/F	(12)	RIO2	Remote IO unit I/F
(5)	FG	Frame ground	(13)	DCIN	24VDC input
(6)	SKIP	Skip input 8ch	(14)	CF01	Power OFF input
(7)	OPI	Operation panel I/O unit I/F (Note 1)	(15)	EMG	External emergency stop input (Note 2)
(8)	SIO	RS-232C communication I/F 2ch			

**(Note 1)** When not using OPI connector, connect the terminator connector E-TM (optional).

**(Note 2)** Use this when not using the Operation panel I/O unit, or when installing an emergency stop switch in the electric cabinet. Connect a terminator (G123 cable) when not using.



**(4) Explanation of expansion unit and connector functions**

Expansion unit connector differs depending on the expansion card integrated into the unit.

[FCU7-HN551/FCU7-HN552 (Optical servo communication I/F)]

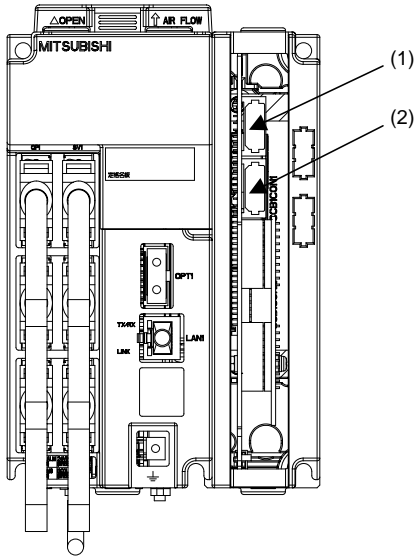

No.	Connector name	Function
(1)	OPT2	Optical servo communication I/F
(2)	OPT3	Optical servo communication I/F

(Note) OPT3 is mounted on FCU7-HN552 only.

[FCU7-HN571 (PROFIBUS-DP 1ch)]

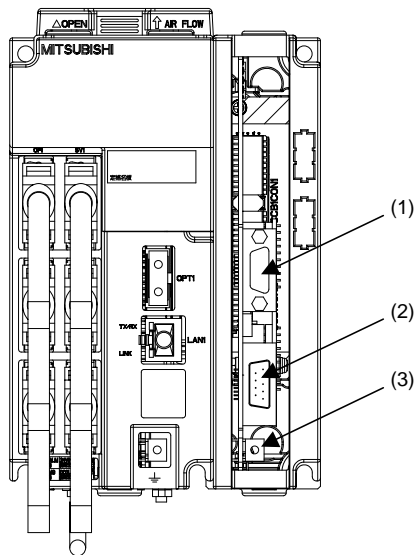

No.	Connector name	Function
(1)	CONF	PROFIBUS-DP configuration I/F
(2)	NET	PROFIBUS-DP communication I/F
(3)	FG	Frame ground



## 4.2 Display Unit

## 4.2.1 FCU7-DA201 (8.4-type)

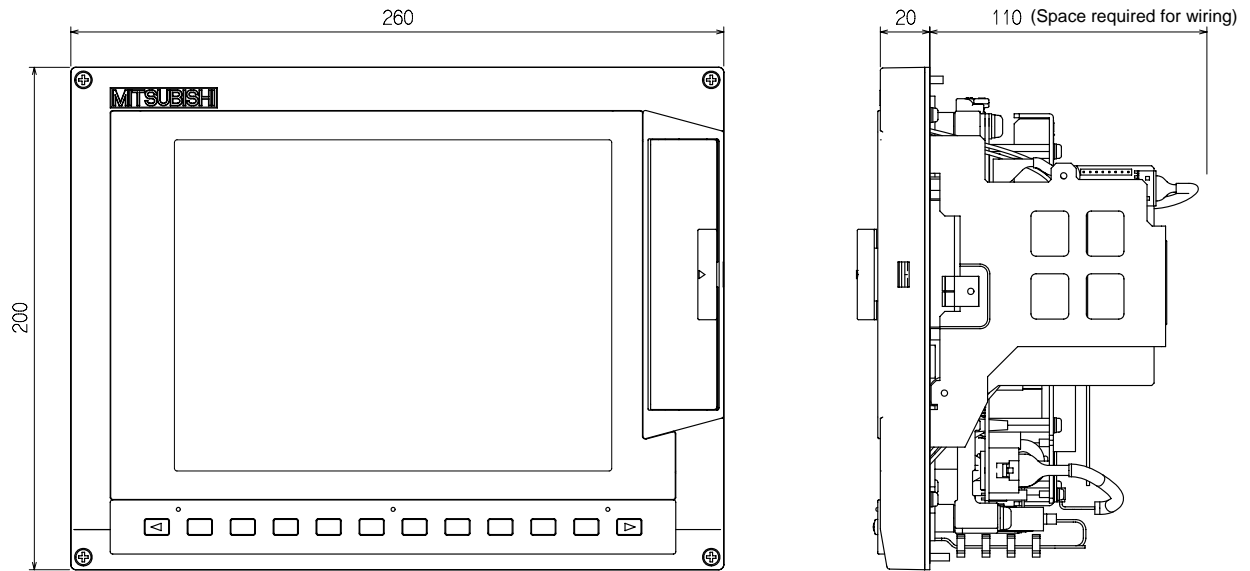

**(Note)** The space of 40mm or more should be provided above the display unit for maintenance.

4.2.2 FCU7-DA211 / FCU7-DA315 / FCU7-DA415 / FCU7-DA445 (10.4-type)

(1) 10.4-type (WindowsCE compatible)

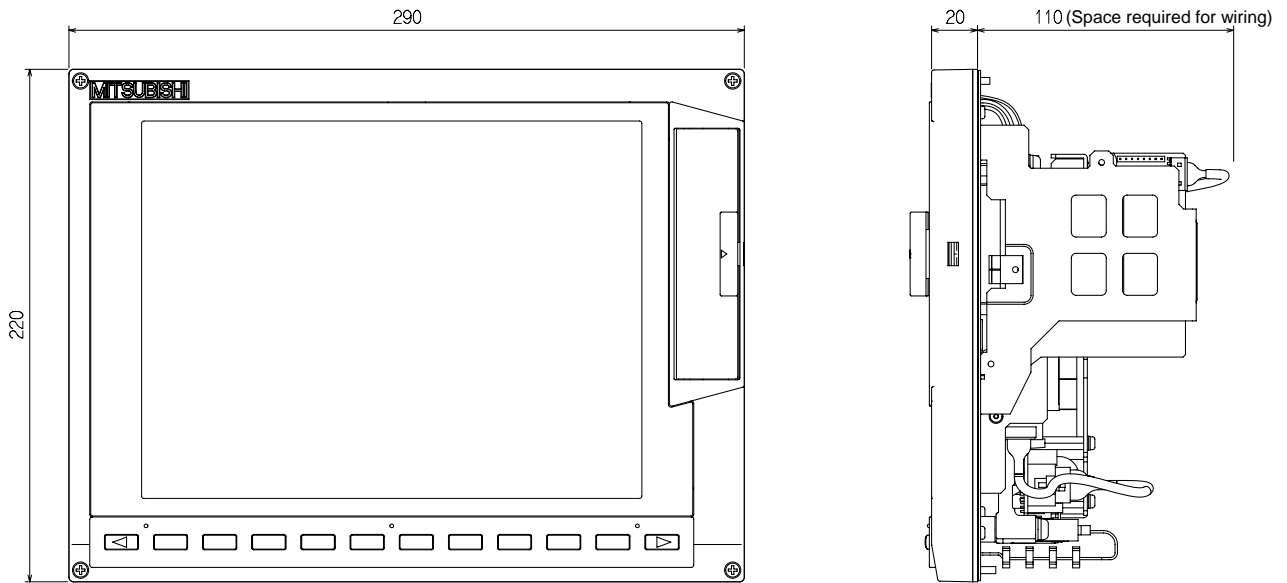

**(Note)** The space of 30mm or more should be provided above the display unit for maintenance.

(2) 10.4-type (WindowsXP compatible)

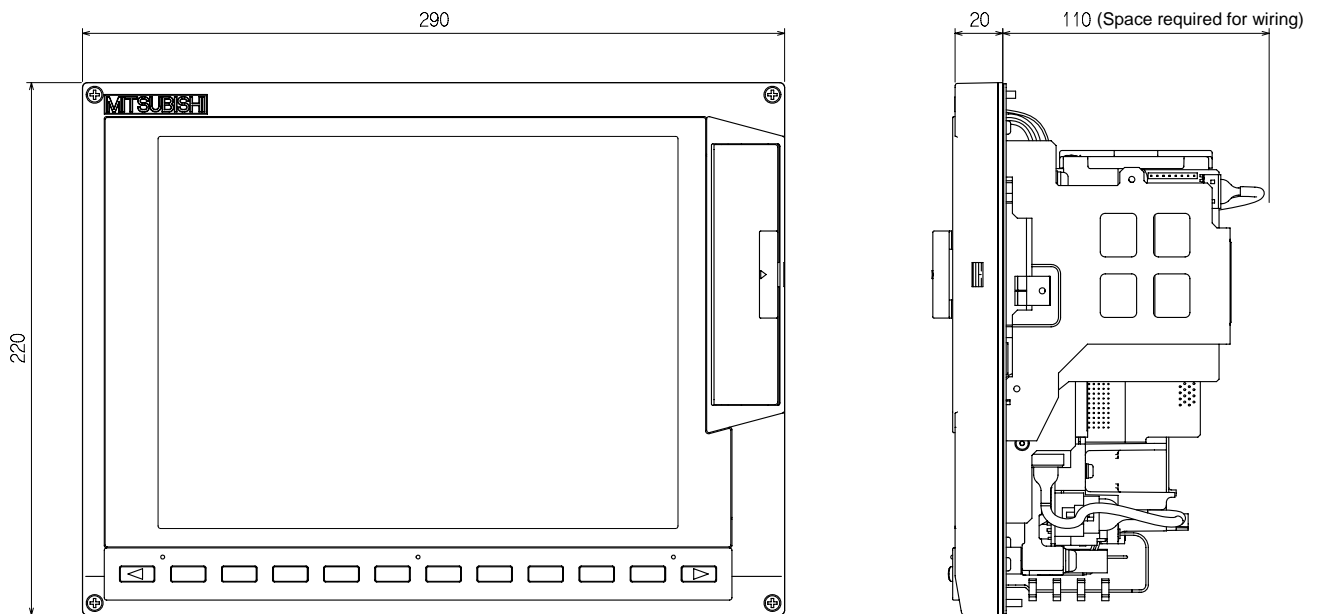

**(Note)** The space of 30mm or more should be provided above the display unit for maintenance.

(3) 10.4-type (WindowsCE compatible) with touch-panel display

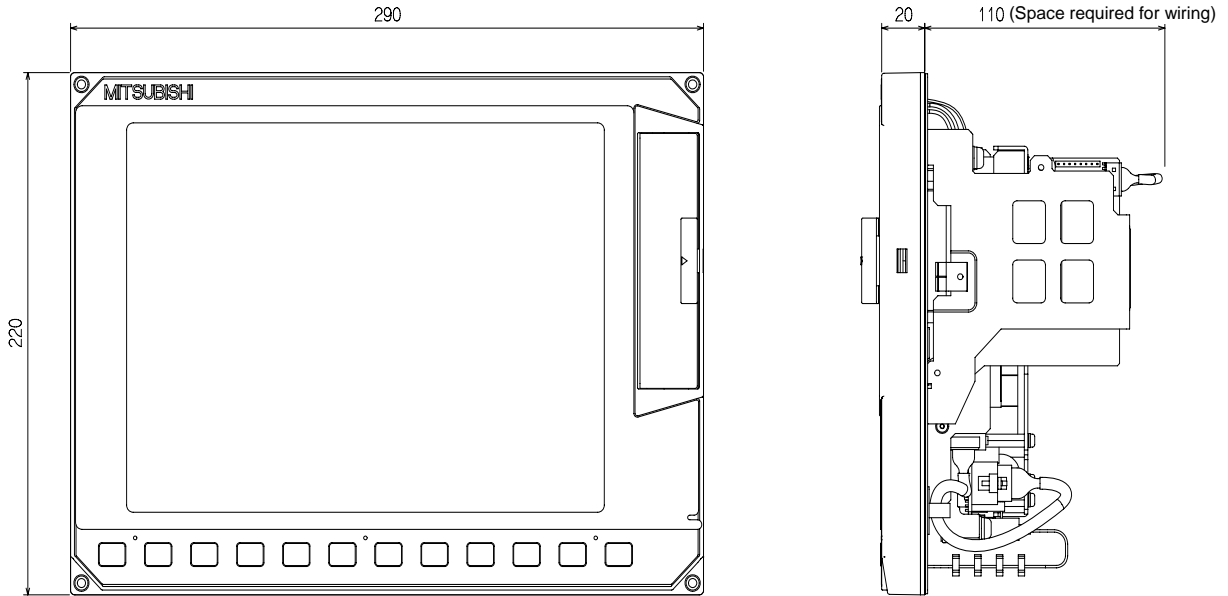

**(Note)** The space of 30mm or more should be provided above the display unit for maintenance.

(4) 10.4-type (WindowsXP compatible) with touch-panel display

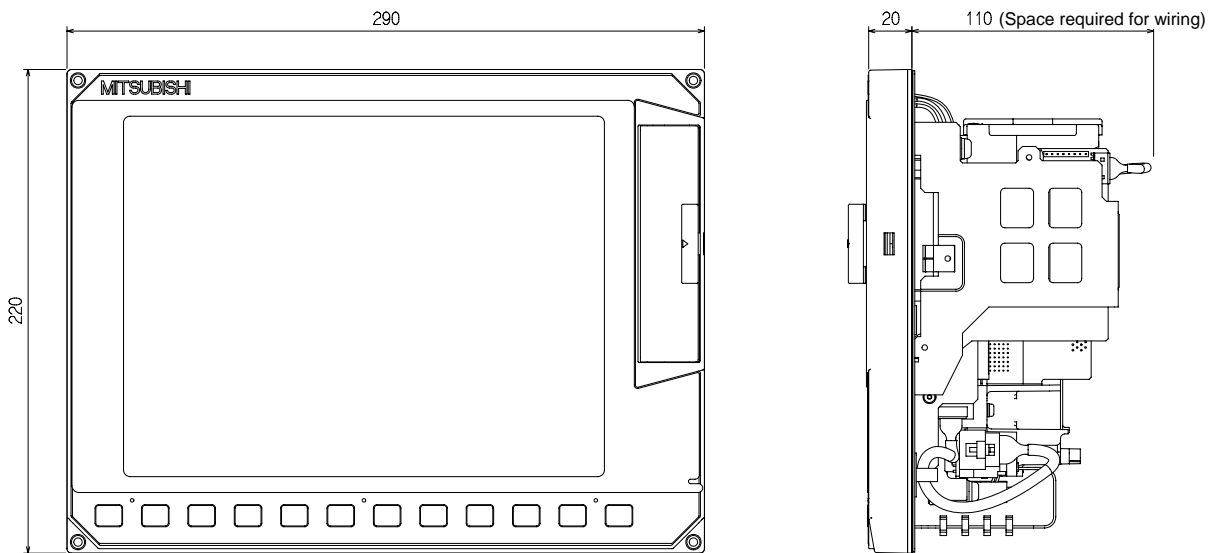

**(Note)** The space of 30mm or more should be provided above the display unit for maintenance.

4.2.3 FCU7-DA335 / FCU7-DA435 (15-type)

(1) 15-type

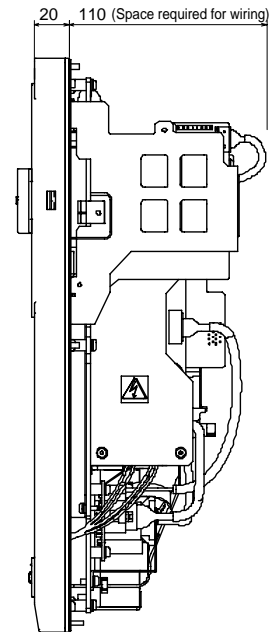
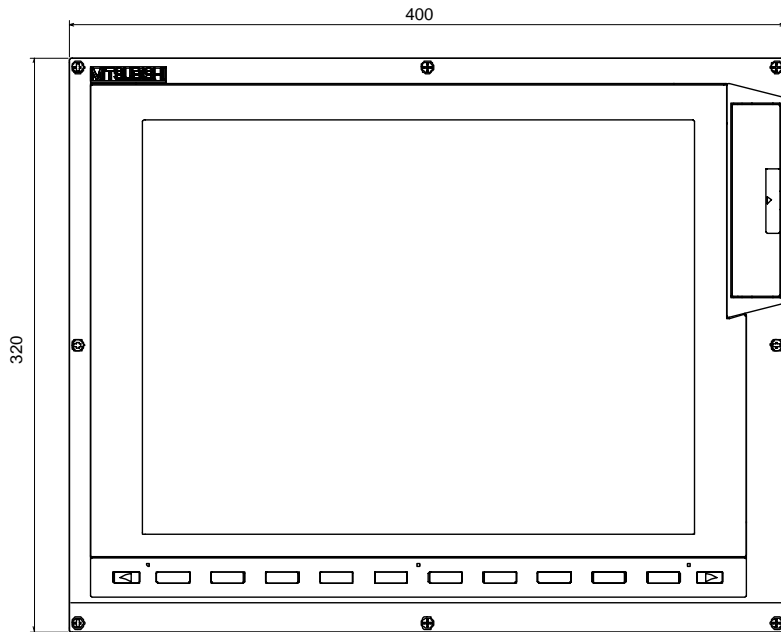

(2) 15-type : with touch panel ; with menu key

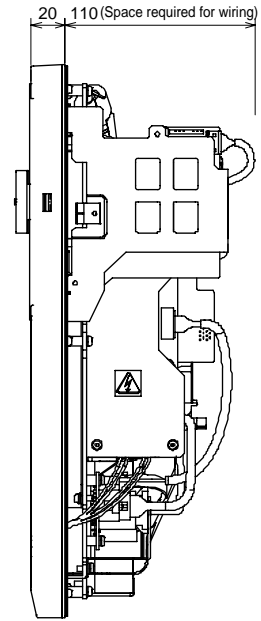
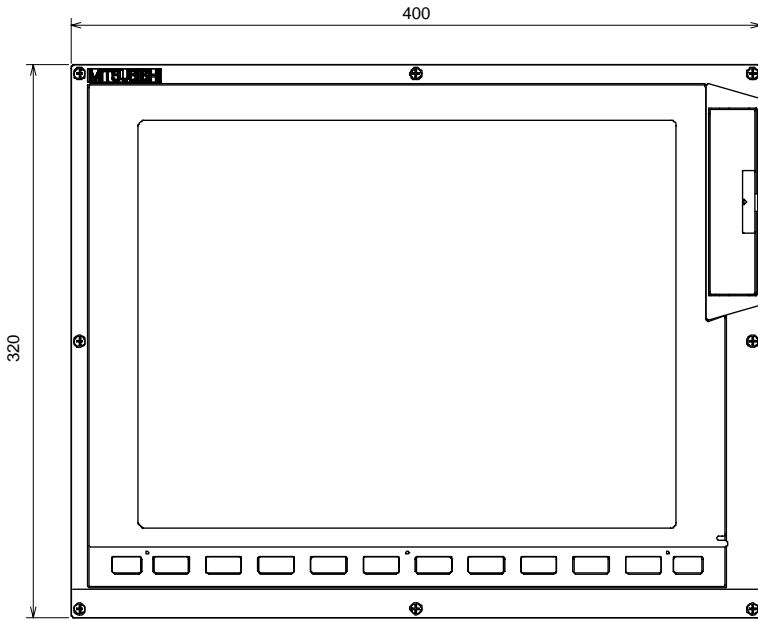

(3) 15-type : with touch panel ; without menu key

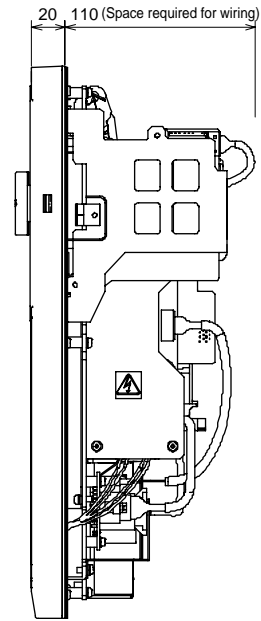
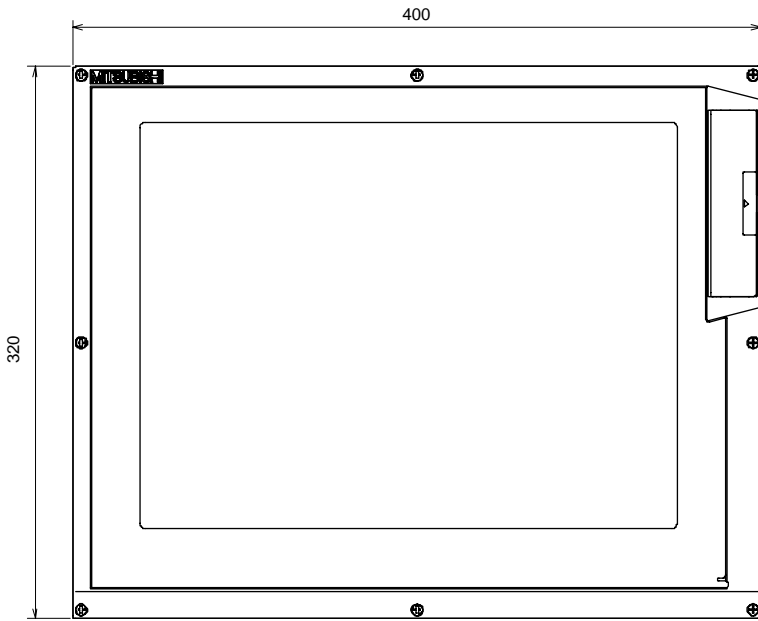

4.2.4 FCU7-DA201 (8.4-type) / FCU7-DA211 (10.4-type) Rear View

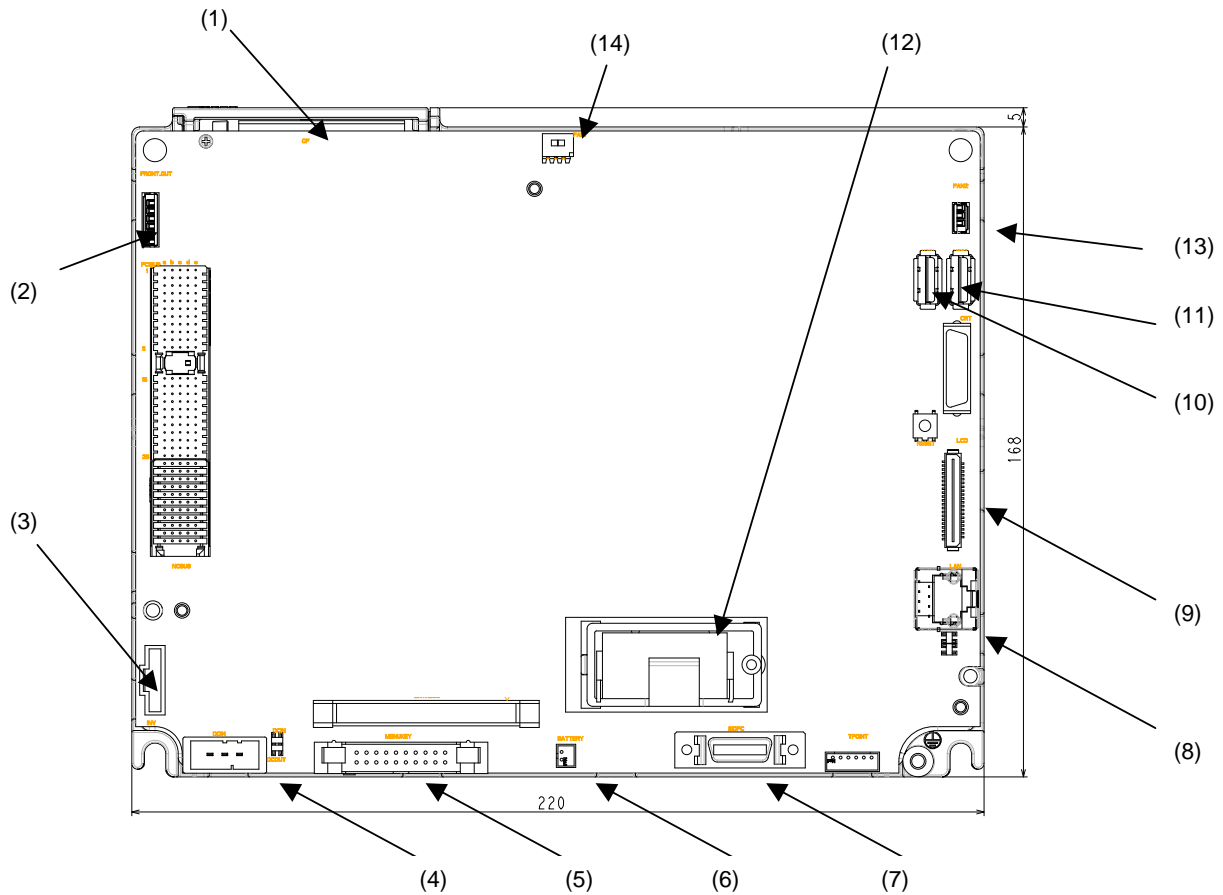

Explanation of display unit and connector functions

No.	Connector name	Function
(1)	CF	Compact flash card I/F (ATA connection specifications)
(2)	FRONT_OUT	Front IC card I/F
(3)	INV	LCD inverter power output
(4)	DCIN	24VDC input
(5)	MENUKEY	Menu key connector
(6)	BAT	Battery connector
(7)	SIO	RS-232C communication I/F 2ch

No.	Connector name	Function
(8)	PCLAN	Personal computer LAN I/F
(9)	LCD	LCD I/F
(10)	USB1	USB (Ver1.1) I/F (5V, max 500mA)
(11)	USB2	USB (Ver1.1) I/F (5V, max 500mA)
(12)	BATTERY	Battery holder Battery: Q6BAT
(13)	FAN2	External fan I/F (24V, max 270mA)
(14)	FAN1	Internal fan I/F (24V)



4.2.5 FCU7-DA315 / FCU7-DA415 / FCU7-DA445 / FCU7-DA335 / FCU7-DA435 Rear View

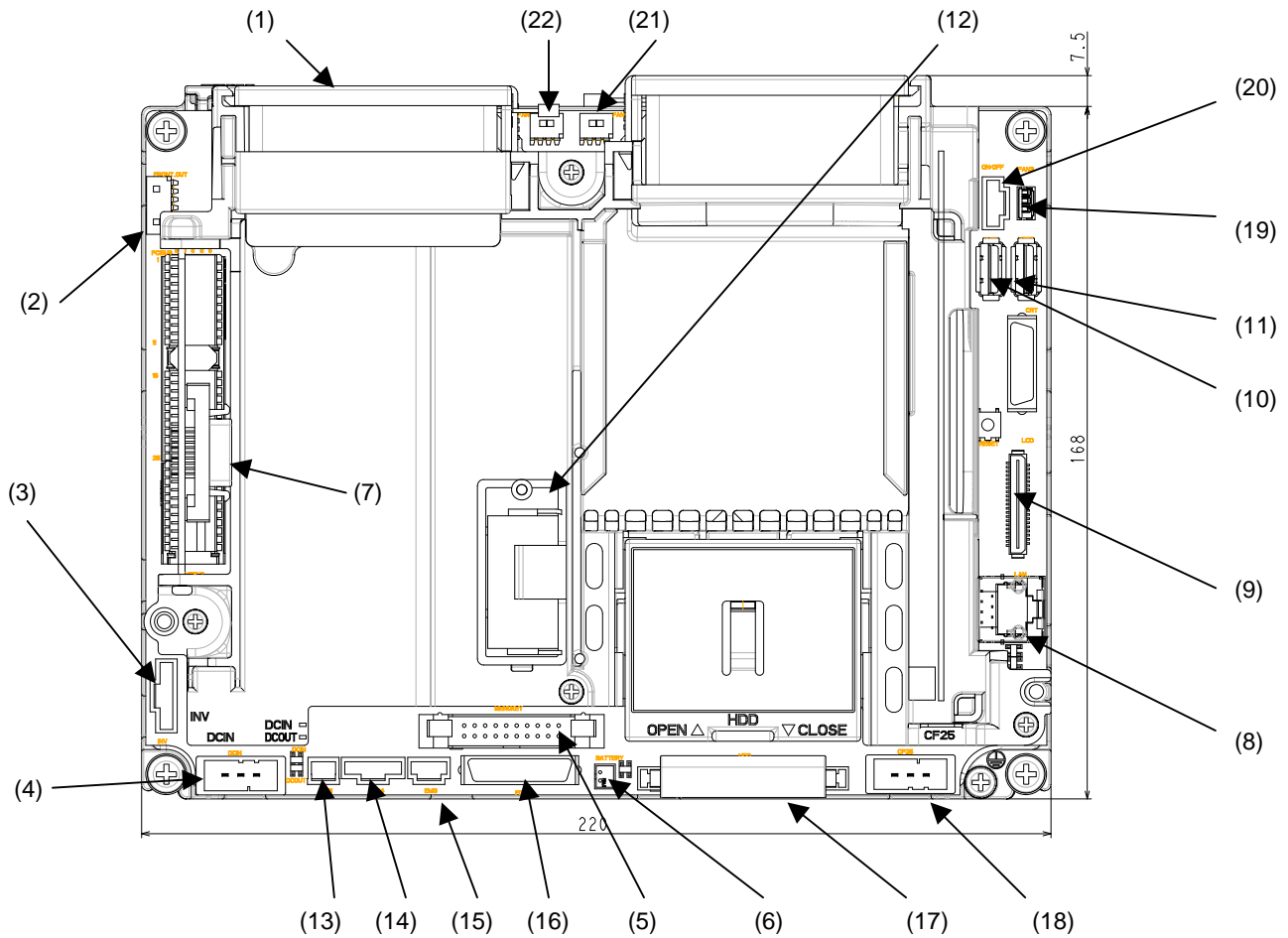

Explanation of display unit and connector functions

No.	Connector name	Function
(1)	CF	Compact flash card I/F (IDE connection specifications)
(2)	FRONT_OUT	Front IC card I/F
(3)	INV	LCD inverter power output
(4)	DCIN	PD25/PD27 power supply I/F 24VDC input
(5)	MENUKEY	Menu key connector
(6)	BAT	Battery connector
(7)	SIO	RS-232C communication I/F 1ch (2ch)
(8)	PCLAN	Personal computer LAN I/F
(9)	LCD	LCD I/F
(10)	USB1	USB (Ver1.1) I/F (5V, max 500mA)
(11)	USB2	USB (Ver1.1) I/F (5V, max 500mA)

No.	Connector name	Function
(12)	BATTERY	Battery holder Battery: Q6BAT
(13)	CF01	PD25/PD27 power supply I/F ACFAIL input
(14)	CF24	PD25/PD27 power supply I/F ON/OFF input/output
(15)	EMG	Not used.
(16)	FDD	Floppy disk I/F
(17)	HDD	Hard disk I/F
(18)	CF25	Not used.
(19)	FAN3	External fan I/F (24V, max 270mA)
(20)	ONOFF	ON/OFF switch I/F
(21)	FAN2	Fan 2 I/F (24V)
(22)	FAN1	Fan 1 I/F (24V)

## 4.2.6 FCU7-EP102 (Front IC Card I/F Unit)

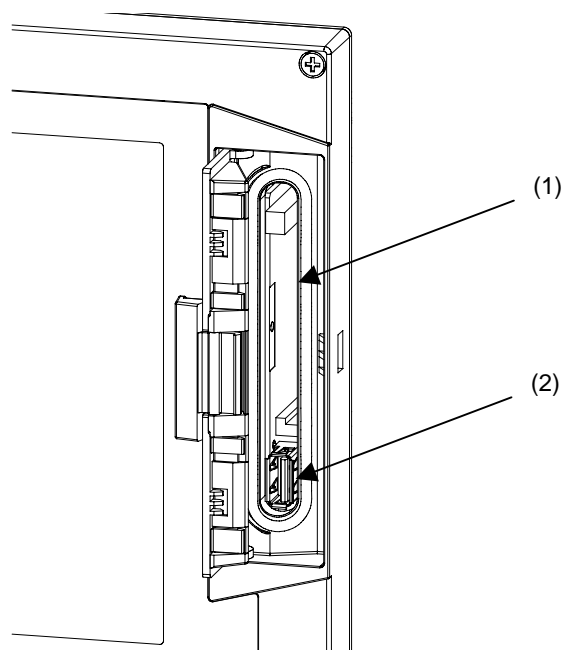

## Explanation of front IC card I/F unit and connector functions

No.	Connector name	Function
(1)	Memory card I/F	PC Card Standard ATA compliant memory card TYPEI, TYPEII only (5VDC : max 220mA)
(2)	USB I/F	USB(Ver1.1)I/F (5V, max 100mA)

4.3 Operation Panel I/O Unit

4.3.1 FCU7-DX670 / FCU7-DX671 / FCU7-DX770 / FCU7-DX771 Outline Drawing

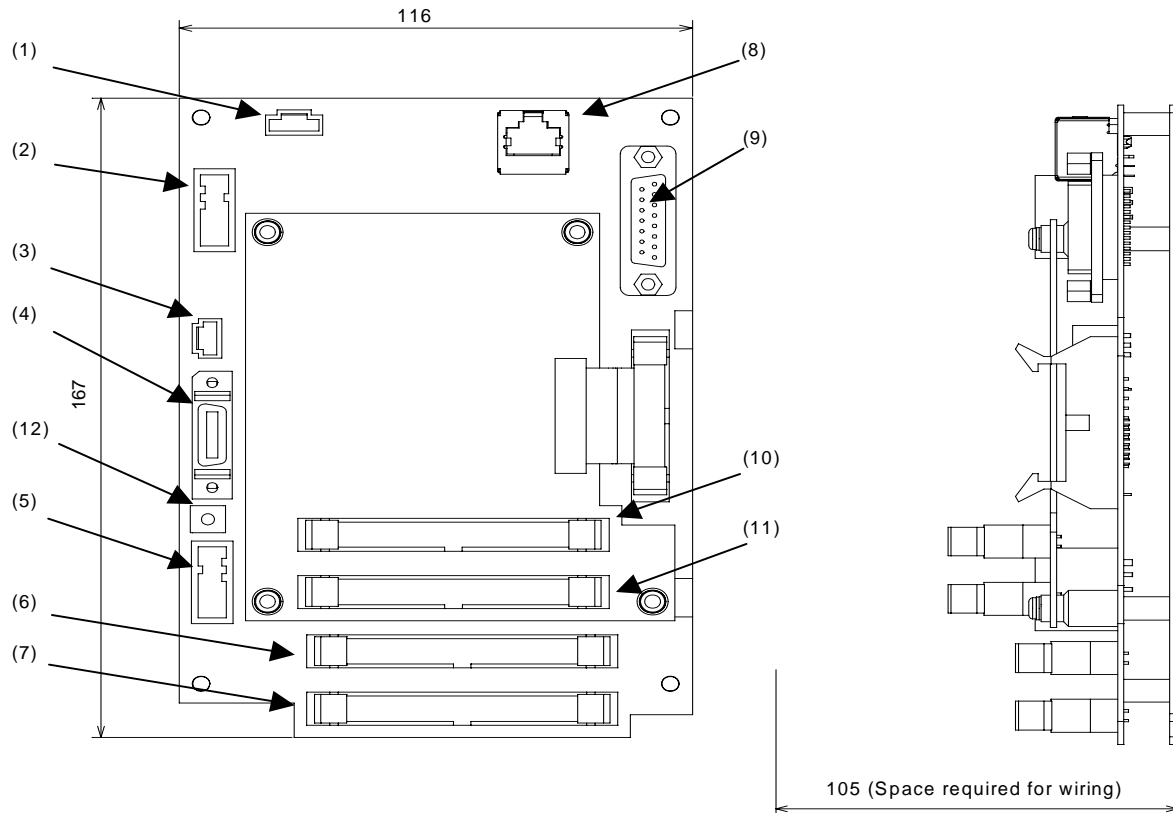

Explanation of Operation panel I/O unit and connector functions

No.	Connector name	Function
(1)	NCRST	NC keyboard → Control unit Reset I/F (DI: 1 point used)
(2)	DCIN	24VDC input
(3)	EMGIN	External emergency stop input for operation panel
(4)	OPI	Control unit connection I/F
(5)	RIO3	Remote I/O Connection I/F for 3rd channel expansion

No.	Connector name	Function
(6)	CG32	DO: 32 points 60mA
(7)	CG31	DI: 32 points
(8)	PCLAN	Display side LAN connection I/F
(9)	MPG	Manual pulse generator 3ch
(10)	CG34	DO: 32 points 60mA
(11)	CG33	DI: 32 points
(12)	FG	RIO3 cable clamp FG

4.4 Keyboard Unit

4.4.1 FCU7-KB021 / FCU7-KB022 (ONG Layout)

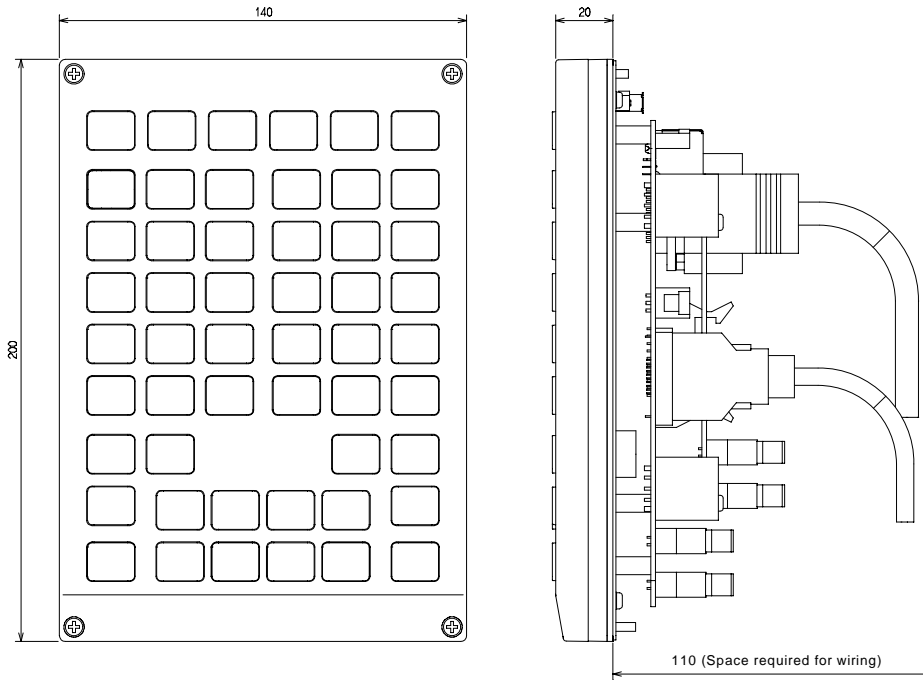

(Note) The above side view shows the state with the Operation panel I/O unit mounted.

4.4.2 FCU7-KB041 (ABC Layout)

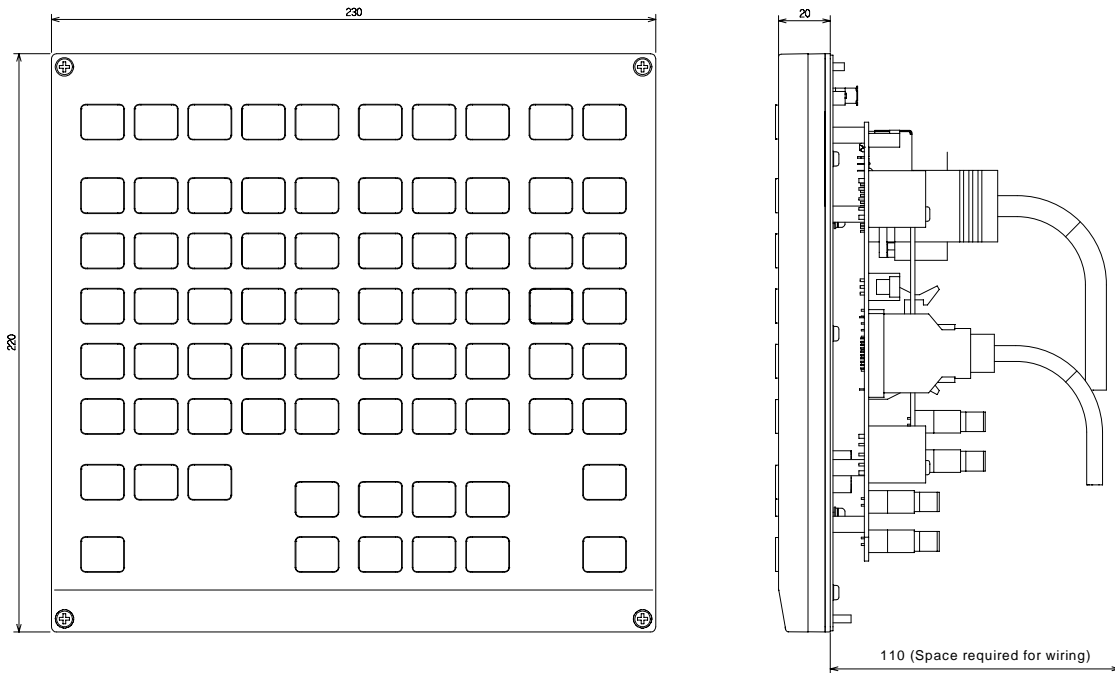

(Note) The above side view shows the state with the Operation panel I/O unit mounted.

## 4.5 Hard Disk Unit

## 4.5.1 FCU7-HD001-1

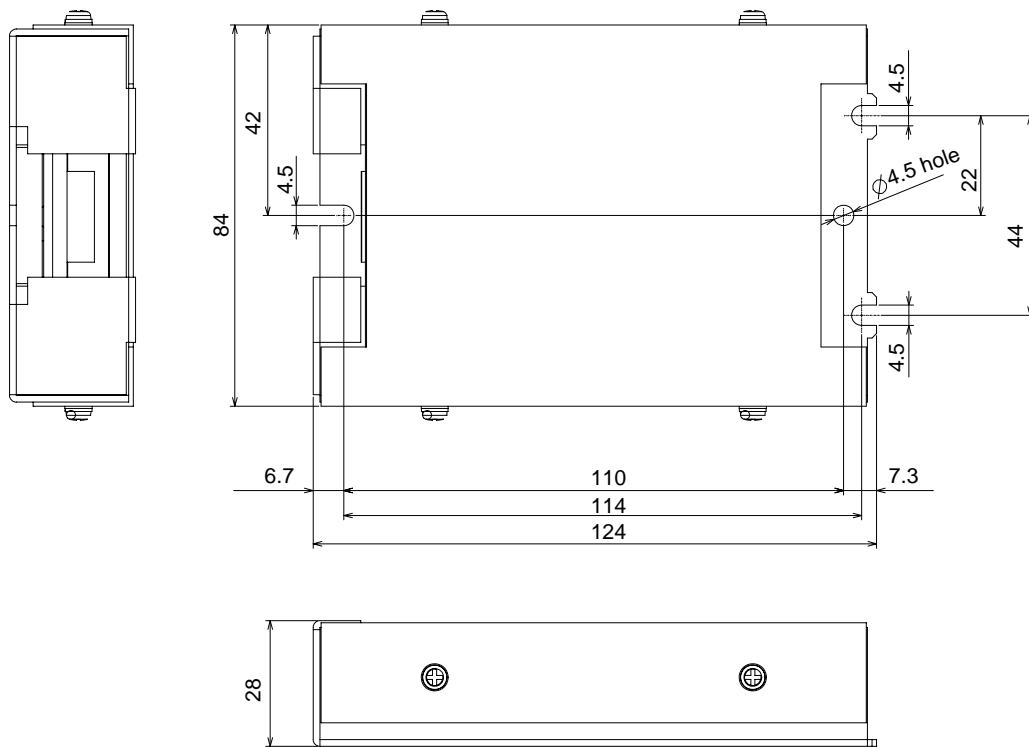

The flat cable (F140) is enclosed.

4.6 Floppy Disk Unit

4.6.1 FCU7-FD221-1

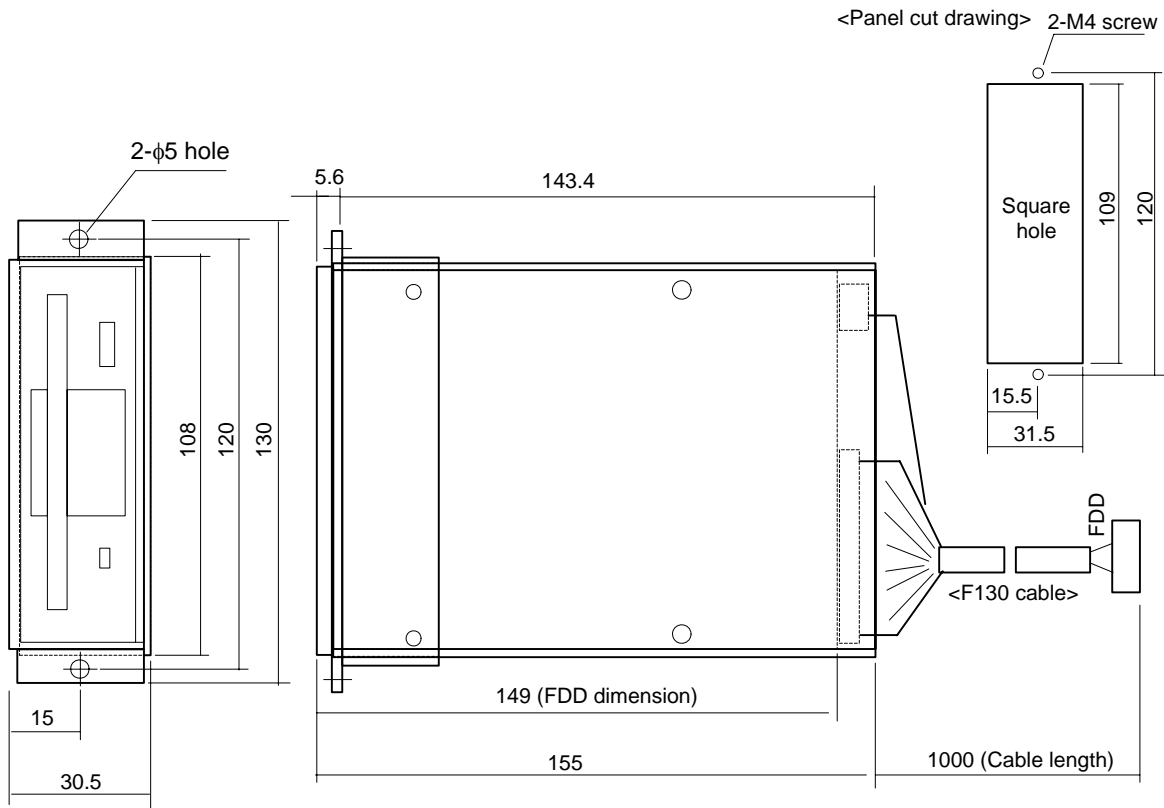

F130 cable is enclosed.

4.7 Card-sized I/O Card

4.7.1 HR361 / HR371 / HR381 / HR383

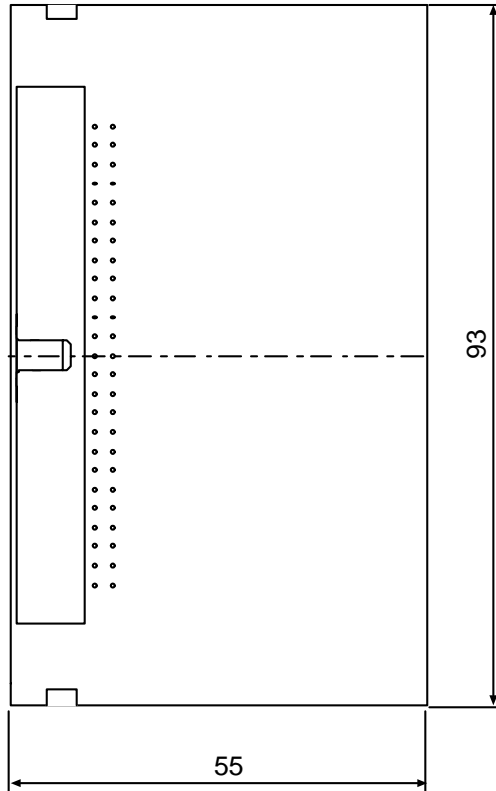

(1) Card corner holder

Use a card corner holder for fixing card-sized I/O card.

Recommended card corner holder: KGCH-20-0 (KITAGAWA INDUSTRIES)

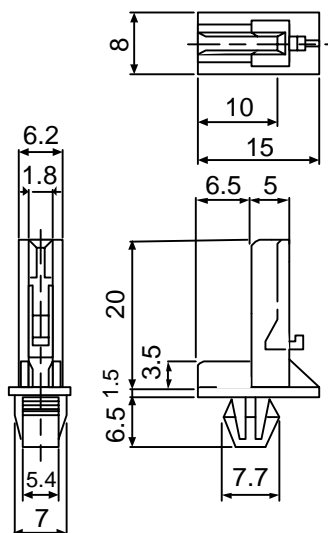

(2) Example of card-sized I/O card connector PCB

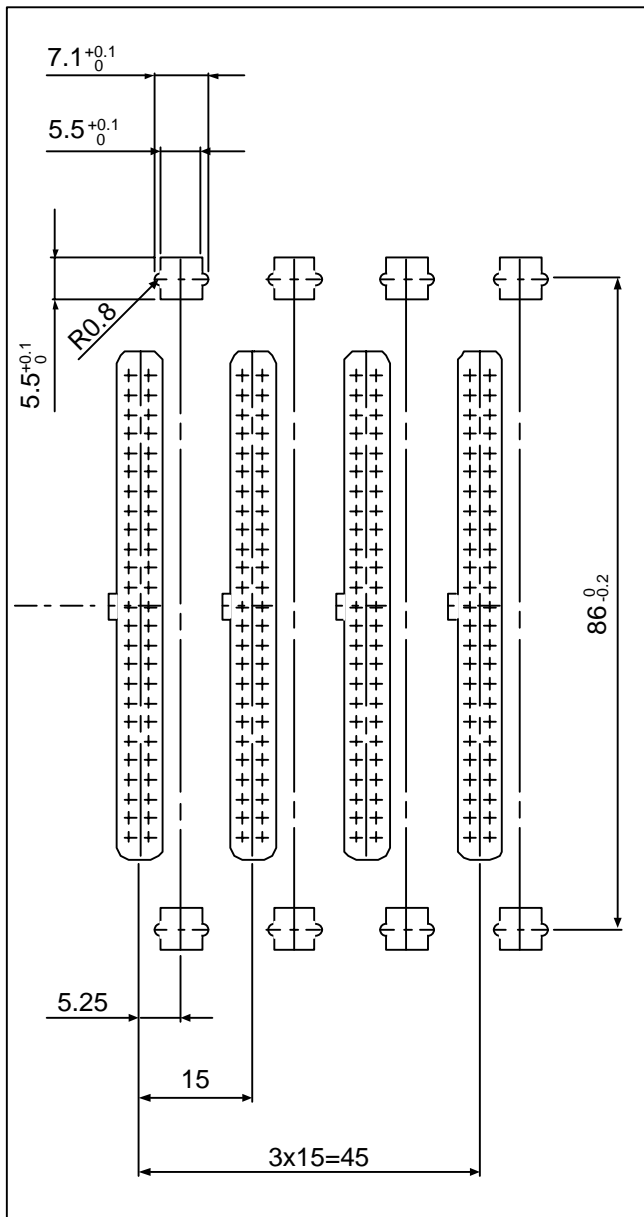



4.8 Remote I/O Unit Outline

4.8.1 FCUA-DX100 / FCUA-DX110 / FCUA-DX120 / FCUA-DX140 / FCUA-DX101 / FCUA-DX111 / FCUA-DX121 / FCUA-DX141

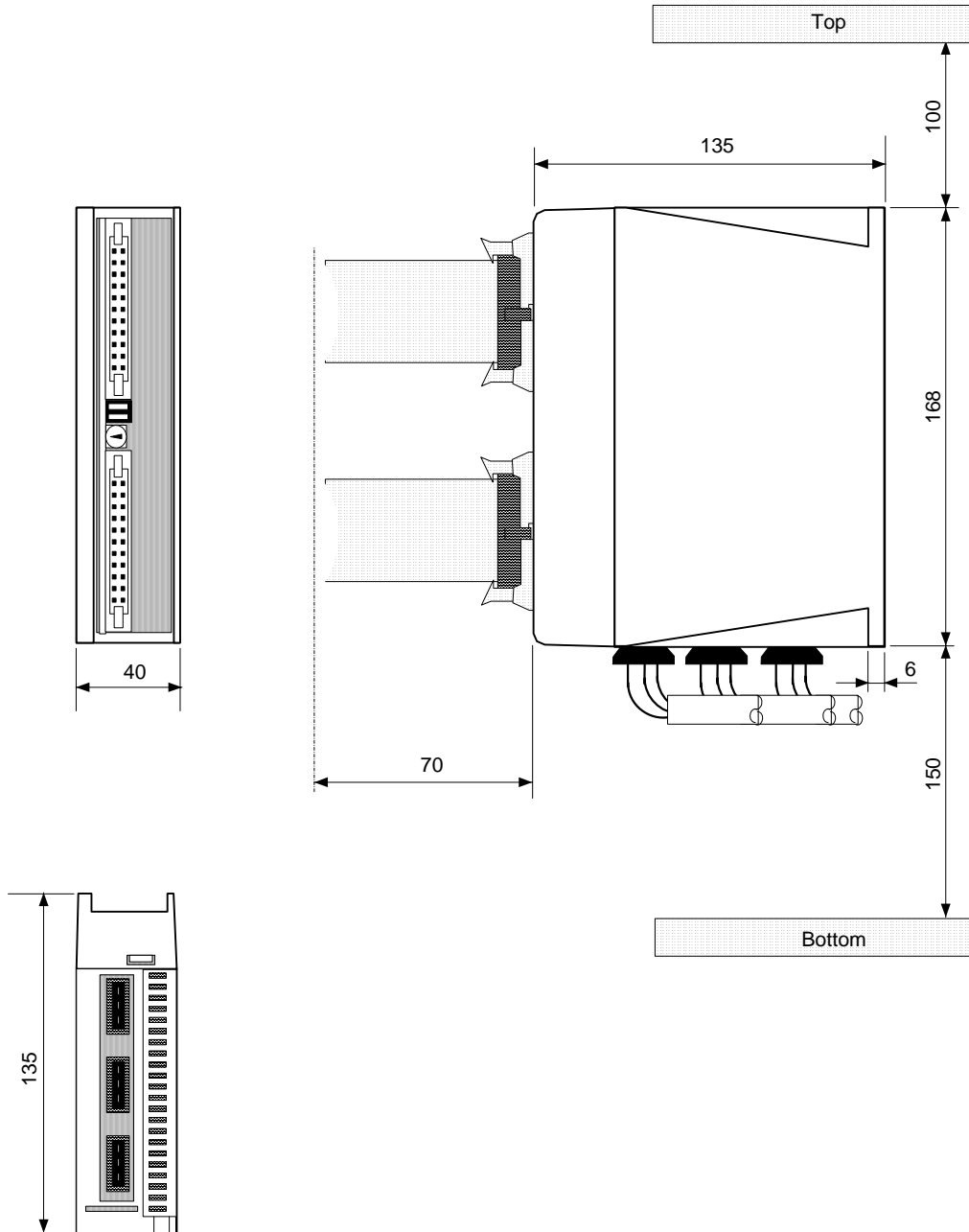

4.9 Grounding Plate and Clamp Fitting

The shield wire generally only needs to be grounded to the connector's case frame. However, the effect can be improved by directly grounding to the grounding plate as shown on the right.

Install the grounding plate near each unit. Peel part of the cable sheath as shown on the right to expose the shield sheath. Press that section against the grounding plate with the clamp fitting. Note that if the cable is thin, several can be clamped together.

Install the grounding plate directly onto the cabinet or connect a grounding wire so that sufficient frame grounding is achieved.

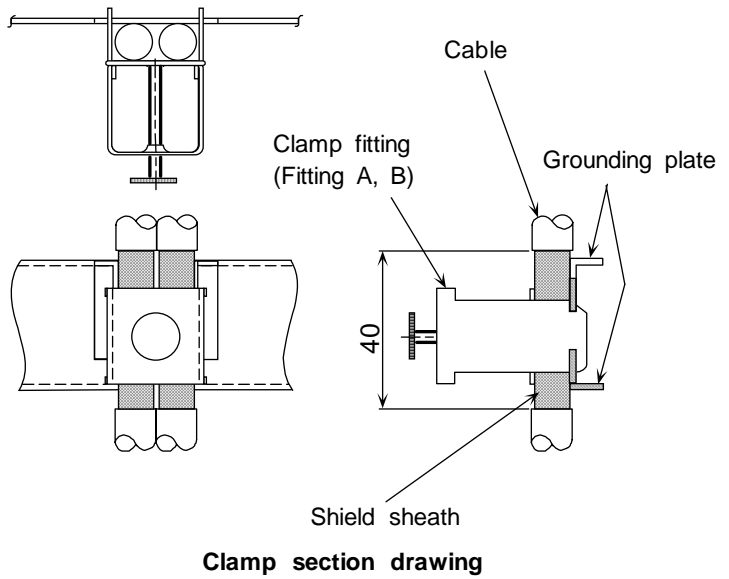

Clamp section drawing

Parts name	Model	Remark
Grounding plate	Grounding plate D	With two clamp fittings A
	Grounding plate E	With one clamp fitting B
Clamp set	Clamp set A	Clamp fittings A, holding parts and fitting threads are enclosed
	Clamp set B	Clamp fitting B, holding parts and fitting threads are enclosed

Outline drawing

Grounding plate

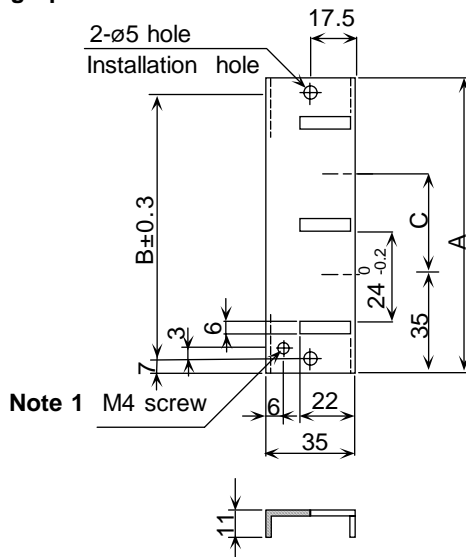

Note 1 M4 screw

Clamp fitting

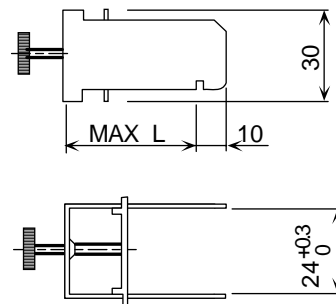

	A	B	C
Grounding plate D	100	86	30
Grounding plate E	70	56	-

	L
Clamp fitting A	70
Clamp fitting B	45

(Note 1) Screw hole for wiring to cabinet's grounding plate

(Note 2) The grounding plate thickness is 1.6mm

## 5. Panel Cut Dimension Drawing / Installation Dimension Drawing

### 5.1 Control Unit

#### (1) Control unit only

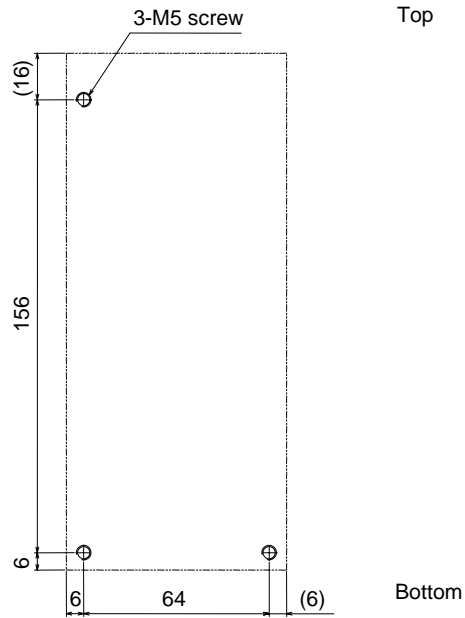

#### (2) With expansion unit

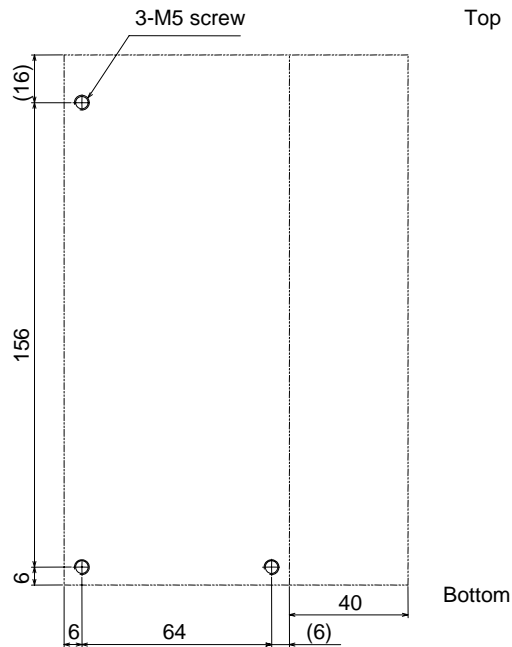

5.2 Display Unit

5.2.1 FCU7-DA201 (8.4-type)

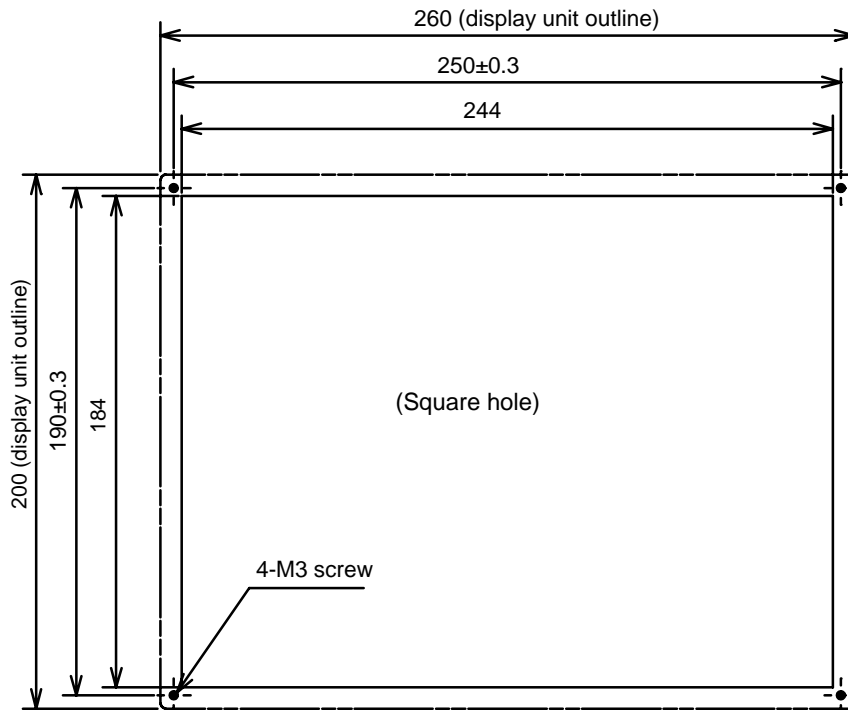

5.2.2 FCU7-DA211 / FCU7-DA315 / FCU7-DA415 / FCU7-DA445 (10.4-type)

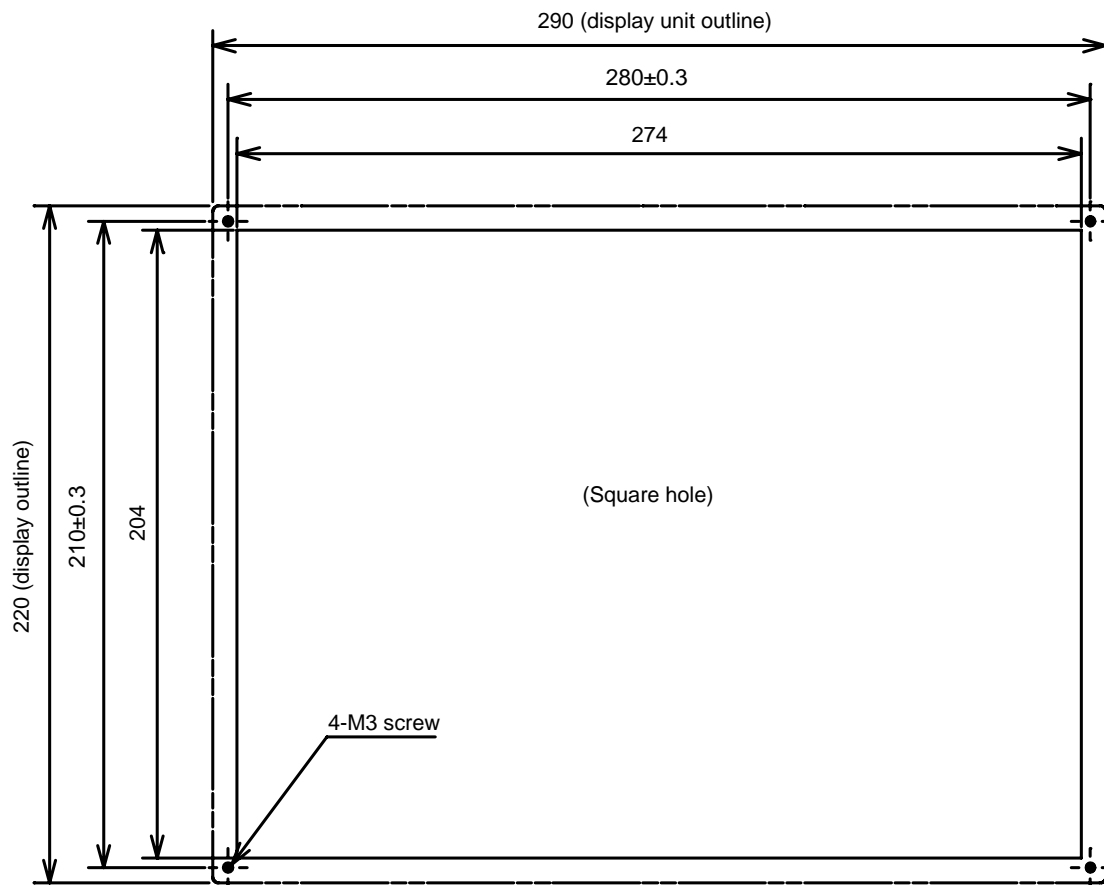

5.2.3 FCU7-DA335 / FCU7-DA435 (15-type)

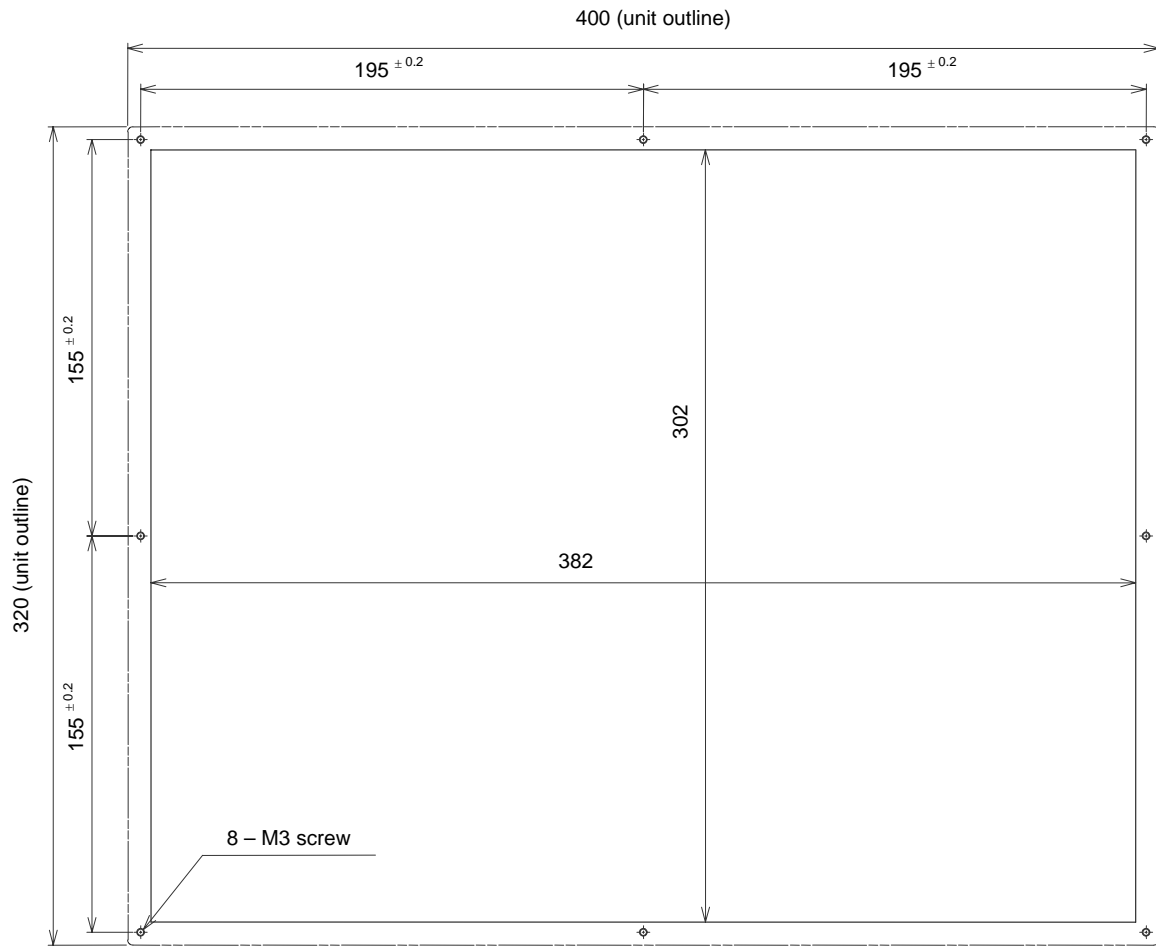

5.3 Operation Panel I/O Unit

5.3.1 FCU7-DX670 / FCU7-DX671 / FCU7-DX770 / FCU7-DX771

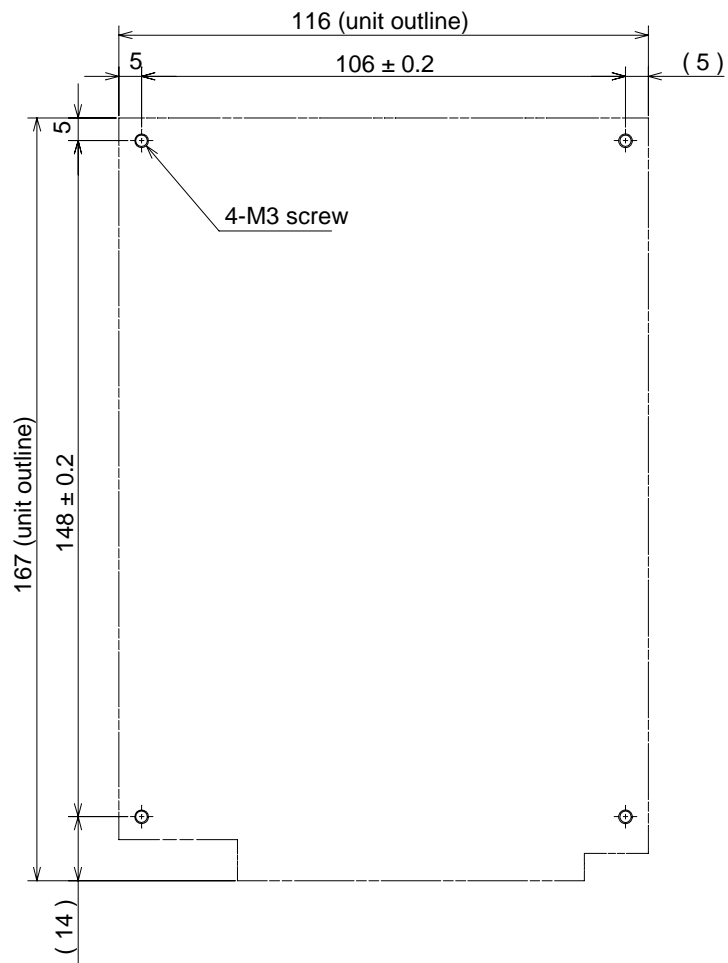

**(Remarks)** When using the Mitsubishi keyboard, the Operation panel I/O unit can be mounted on the back of the keyboard.

5.4 Keyboard Unit

5.4.1 FCU7-KB021 / FCU7-KB022 (ONG Layout)

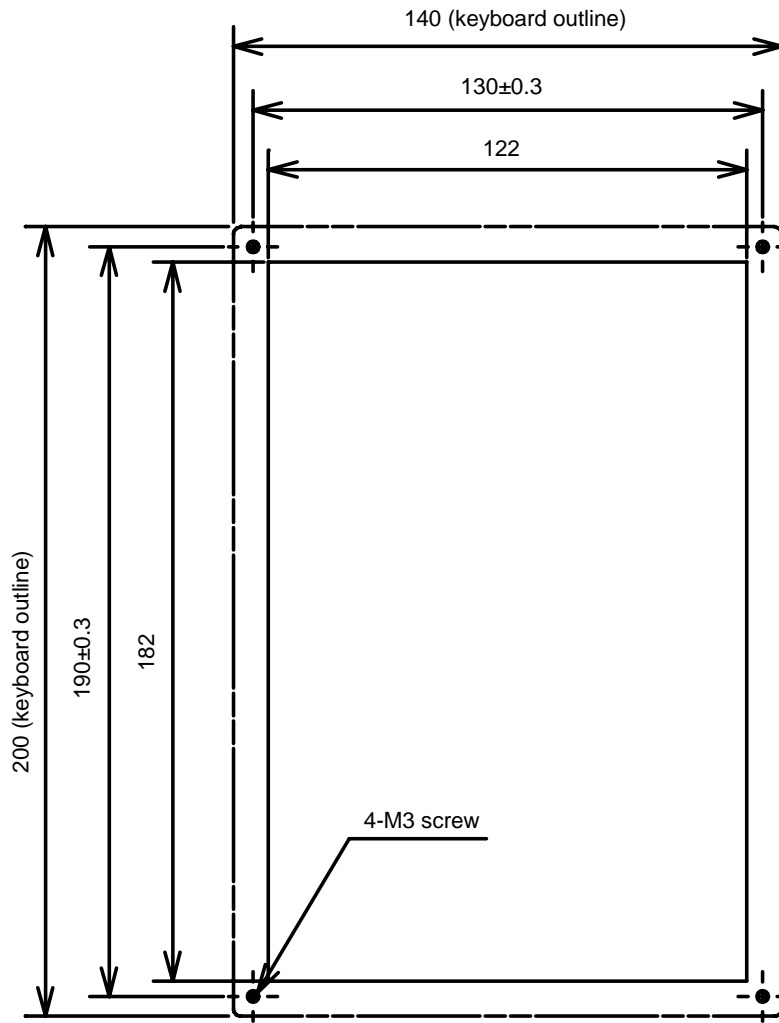



5.4.2 FCU7-KB041 (ABC Layout)

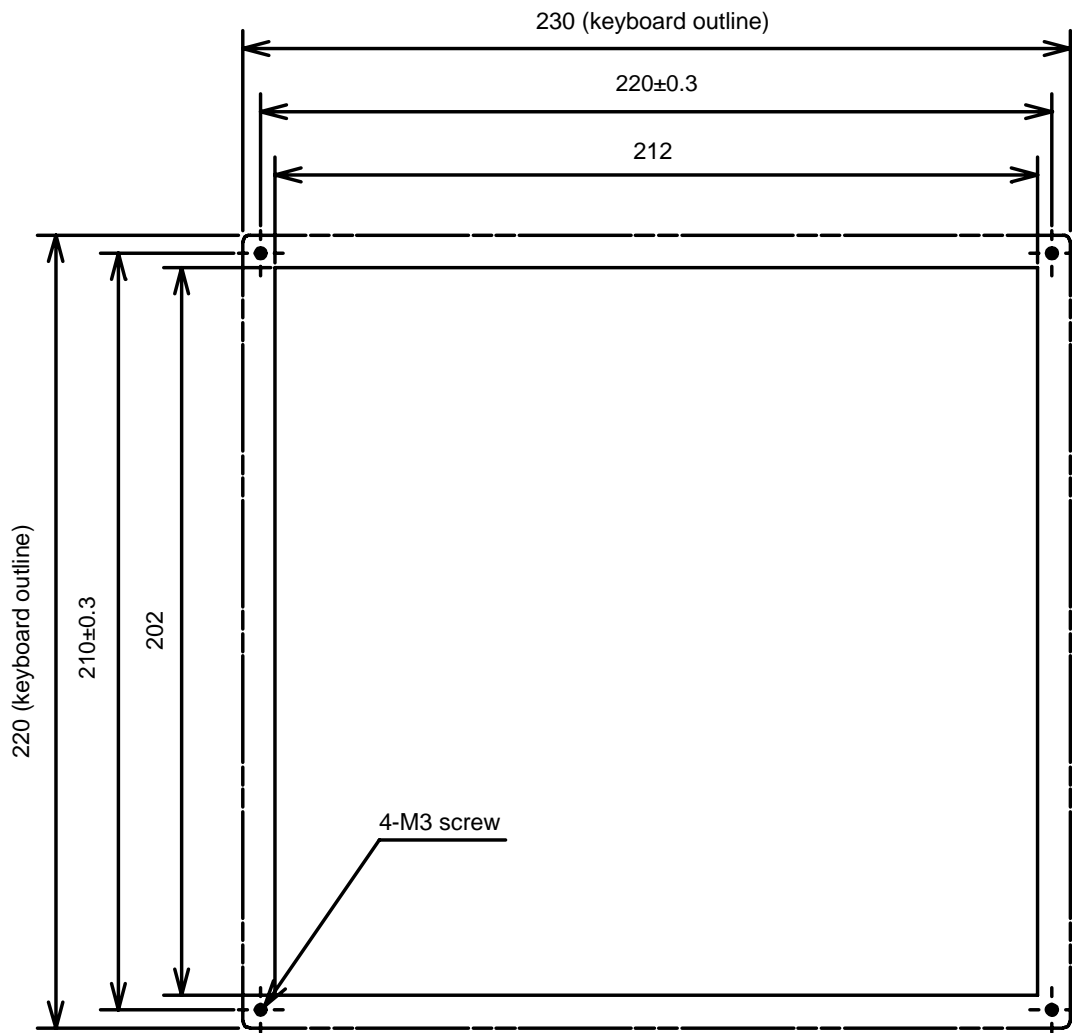

5.5 Hard Disk Unit

5.5.1 FCU7-HD001

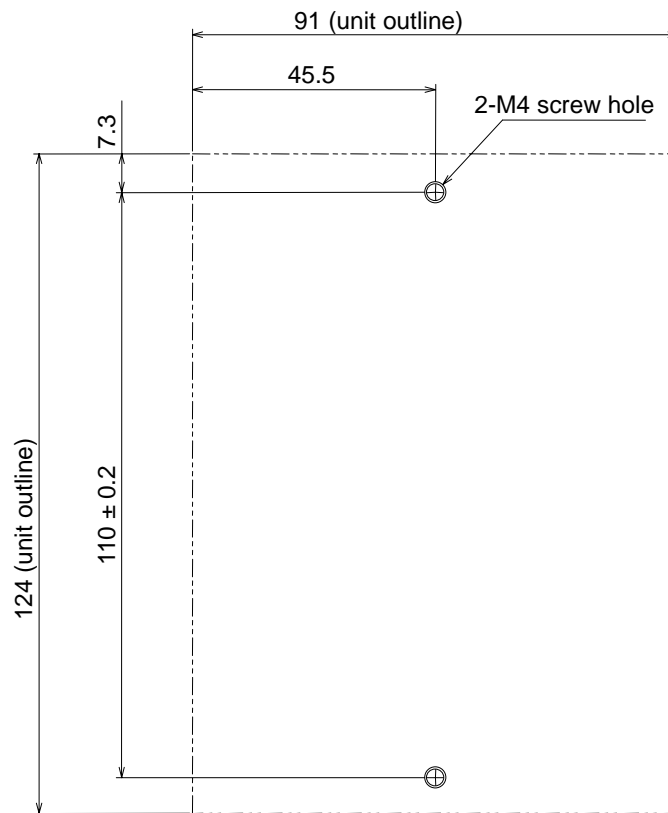

**(Note)** When mounting the hard disk unit, face the cable lead-out side directly straight up, and mount within ±15°.

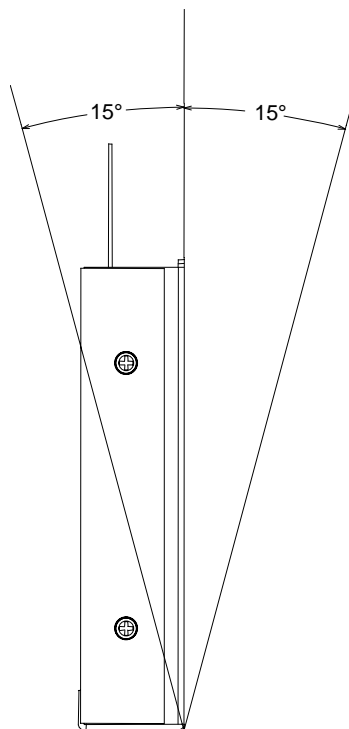

5.5.2 Mounting on a Keyboard Unit

Fix the hard disk unit on the back of the keyboard unit (FCU7-KB041) as follows, with 3 pieces of M4 screws.

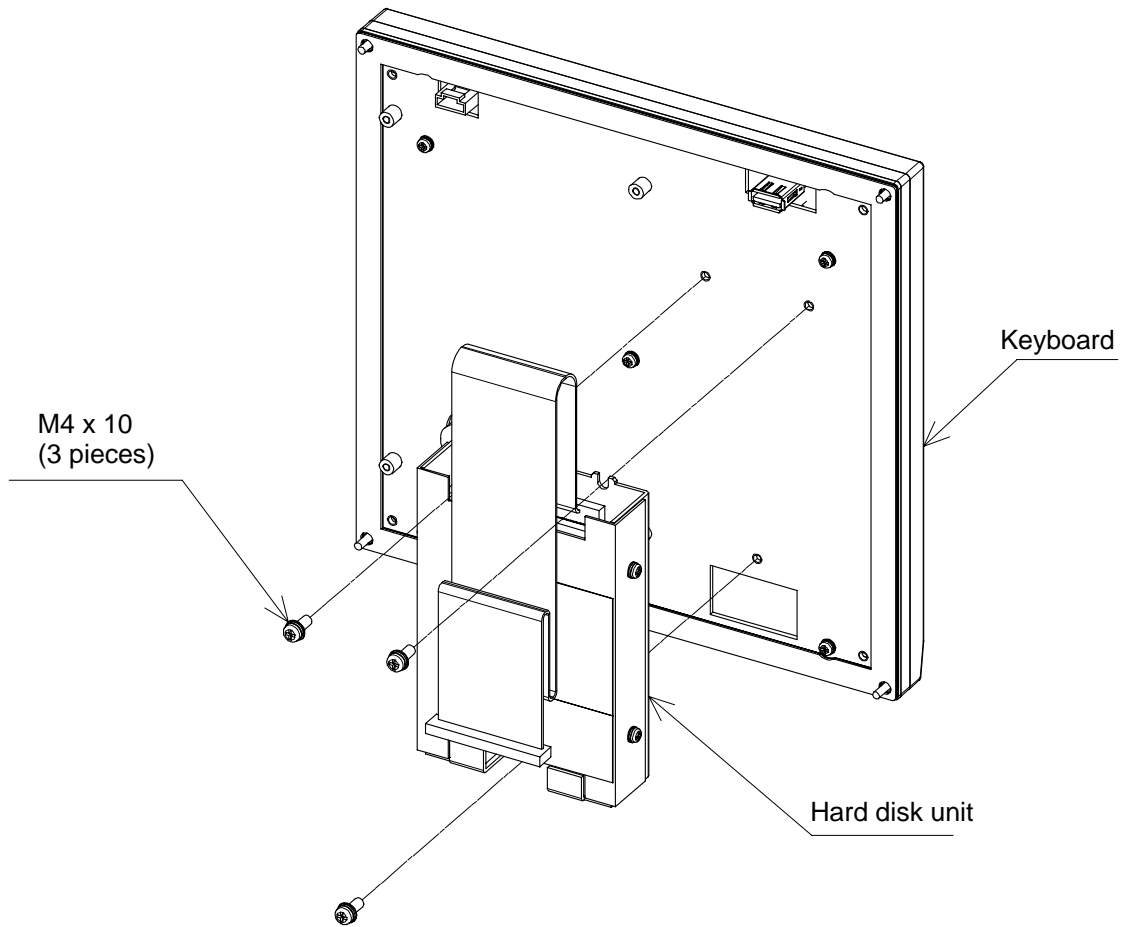

5.6 External Power Supply Unit

5.6.1 PD25

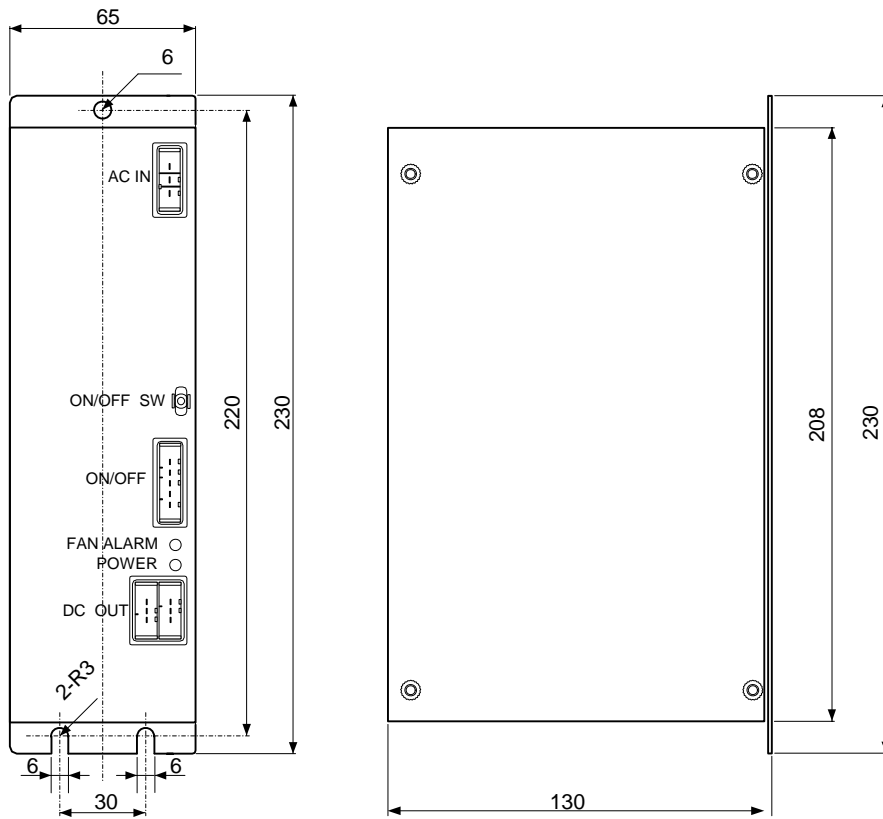

## 5. Panel Cut Dimension Drawing / Installation Dimension Drawing

### 5.6 External Power Supply Unit

#### 5.6.2 PD27

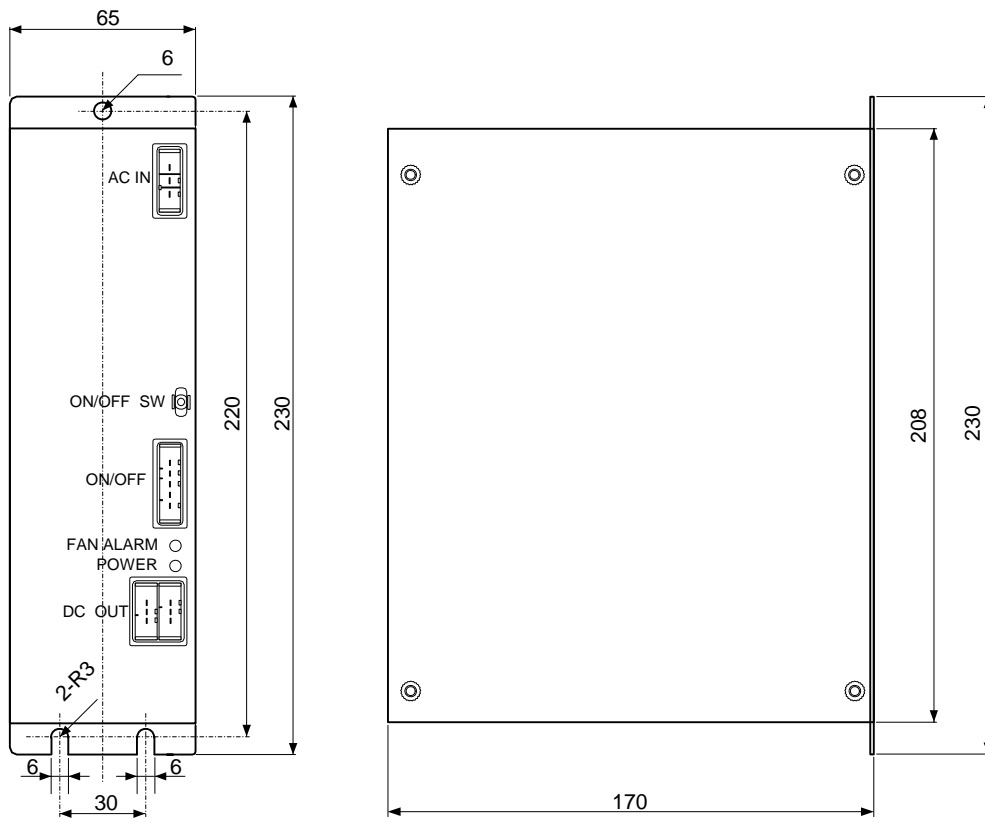

#### 5.6.3 Mounting Direction and Clearance

Mount the external power supply unit vertically and so that it is visible from the front. Provide space for heat dissipation and ventilation.

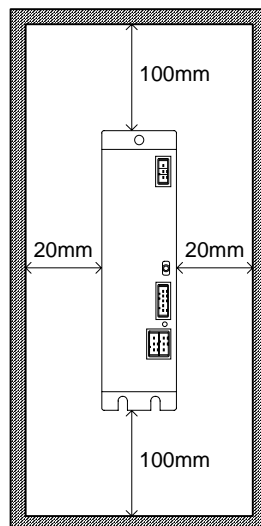

5.7 Remote I/O Unit

5.7.1 FCUA-DX100 / FCUA-DX110 / FCUA-DX120 / FCUA-DX140 / FCUA-DX101 / FCUA-DX111 / FCUA-DX121 / FCUA-DX141

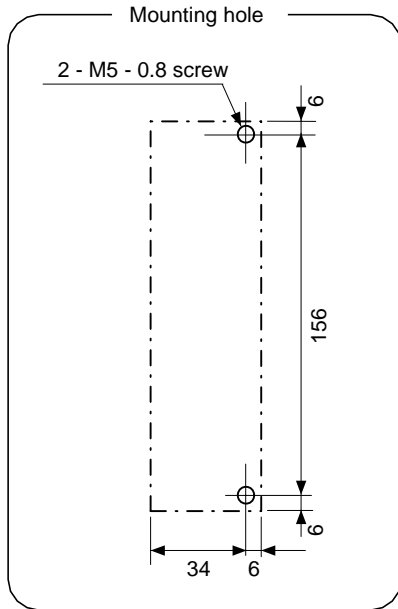

5.8 Manual Pulse Generator

5.8.1 UFO-01-2Z9

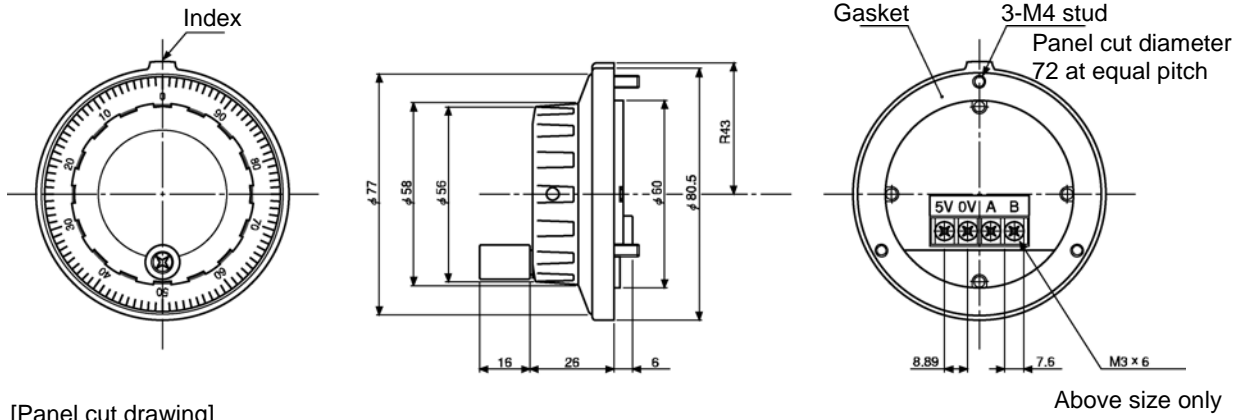

[Panel cut drawing]

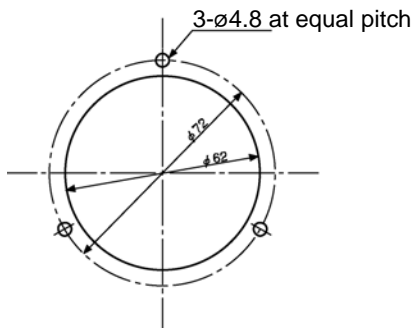

Produced by NIDEC NEMICON CORPORATION

**(Note)** This product does not comply with the MELDAS specifications.

5.8.2 HD60

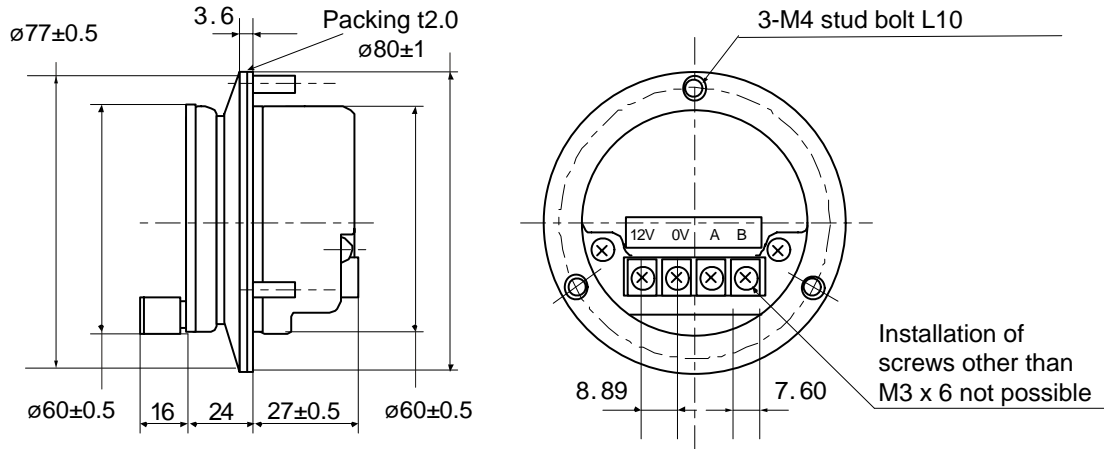

[Panel cut drawing]

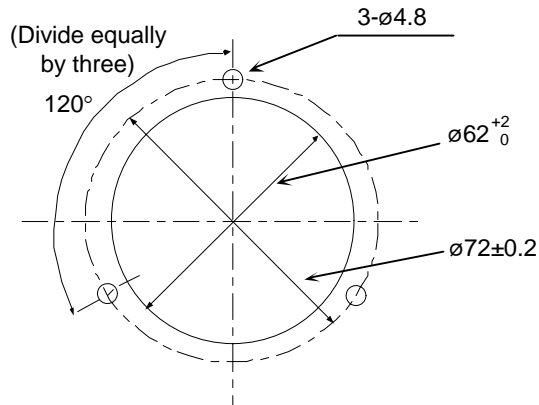



5.9 Synchronous Feed Encoder

5.9.1 OSE-1024-3-15-68

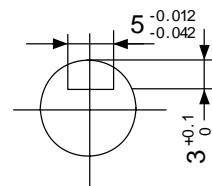
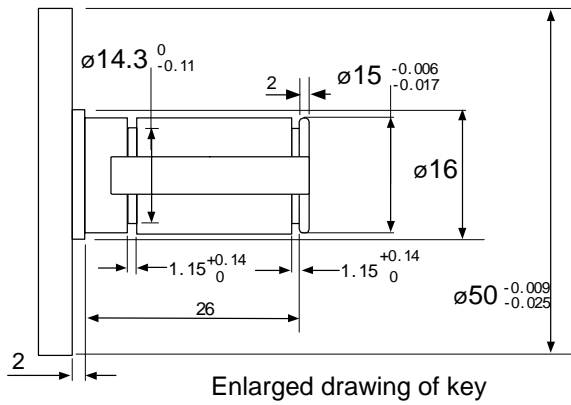
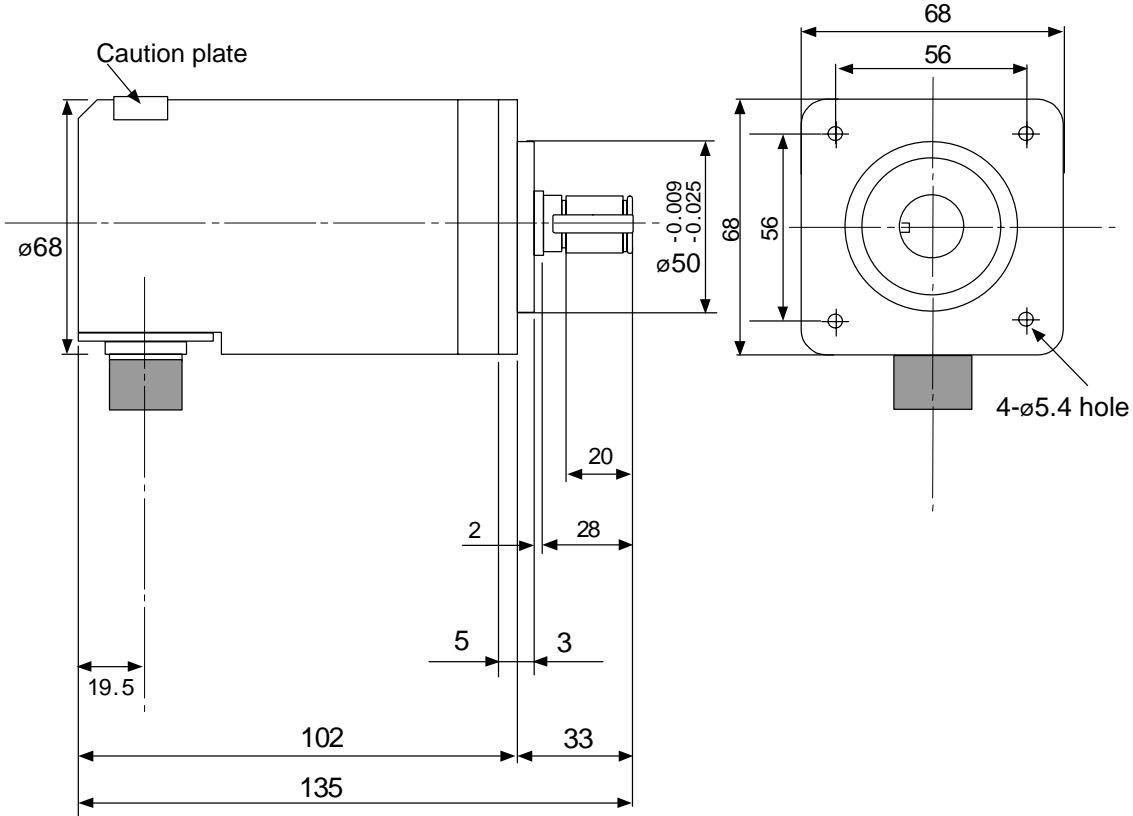

Cross section BB  
Valid depth of key groove is 21mm

5.10 F Installation Plate

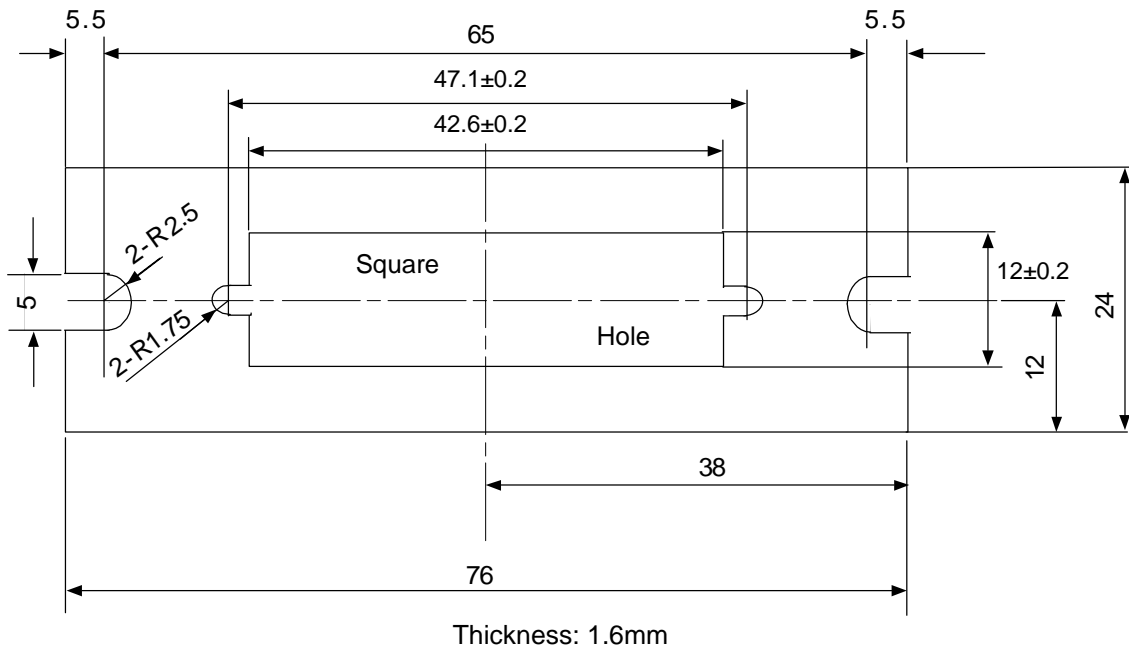

## 6. Connections of Control Unit

The method for connecting to each unit and device from the control unit are briefly explained in this section.

### 6.1 Control Unit Connection System Drawing

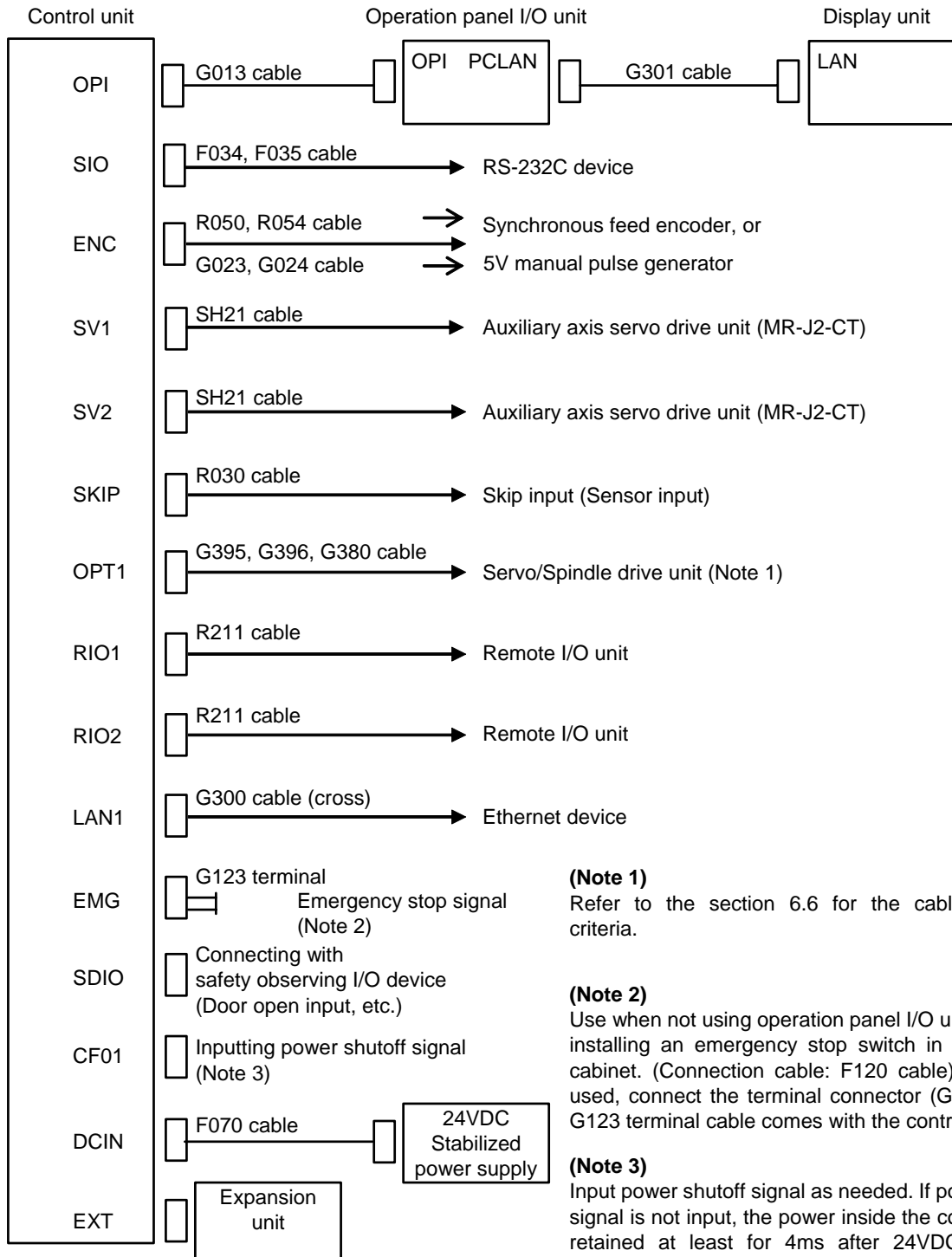

**(Note 1)**  
Refer to the section 6.6 for the cable selection criteria.

**(Note 2)**  
Use when not using operation panel I/O unit, or when installing an emergency stop switch in the electric cabinet. (Connection cable: F120 cable) When not used, connect the terminal connector (G123 cable). G123 terminal cable comes with the control unit.

**(Note 3)**  
Input power shutoff signal as needed. If power shutoff signal is not input, the power inside the control unit is retained at least for 4ms after 24VDC stabilized power supply has been shutoff.

6.2 Connecting with Power Supply

Connect a general-purpose 24VDC stabilized power supply or PD25/PD27 power supply unit to the control unit.

6.2.1 When Using General-Purpose 24VDC Stabilized Power Supply

(1) Connection of power supply

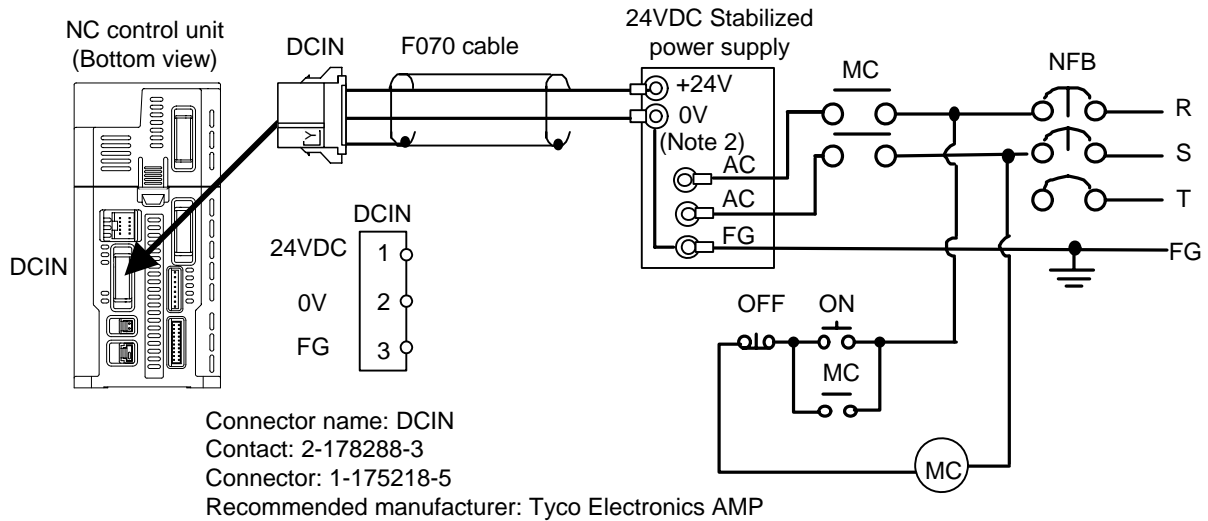

<Related items>

Cable drawing: "Appendix 2 (F070 cable)"

Connector pin assignment: "Appendix 3 (DCIN connector)"

**(Note 1)** Rush current may occur to lead welding on the contacts, when a magnetic switch such as relay directly controls 24VDC's ON/OFF during 24V power supply to the control unit.

Use relay with large heat capacity of contacts to control 24VDC's ON/OFF.

**(Note 2)** Make a short-circuit between OV and FV on the terminal block to cut noise.

(2) Specifications of power supply

Consider the following characteristics when selecting the stabilized power supply (prepared by machine tool builder). Use a power supply that complies with CE Marking or that follows the safety standards given below.

[Stabilized power supply selection items]

Item		Standard setting	Remarks
Output	Voltage fluctuation	±5%	±5% or less of 24VDC output
	Ripple noise	240mV (P-P)	
Output current		--	Refer to the maximum current consumption of the unit in use and calculate.
Output holding time		20ms	Instantaneous power failure time (AC side)

[Standards]

Safety Standards : UL1950, CSA C22.2 No. 234 approved, IEC950 compliant

Noise Terminal Voltage : FCC Class A, VCCI-Class A

High Harmonics Current Restrictions : IEC61000-3-2

6.2.2 When Using PD25/PD27 Power Supply Unit

When using ACFAIL signal for control, use PD25/PD27 power supply unit.

(1) Connection of PD25/PD27 power supply

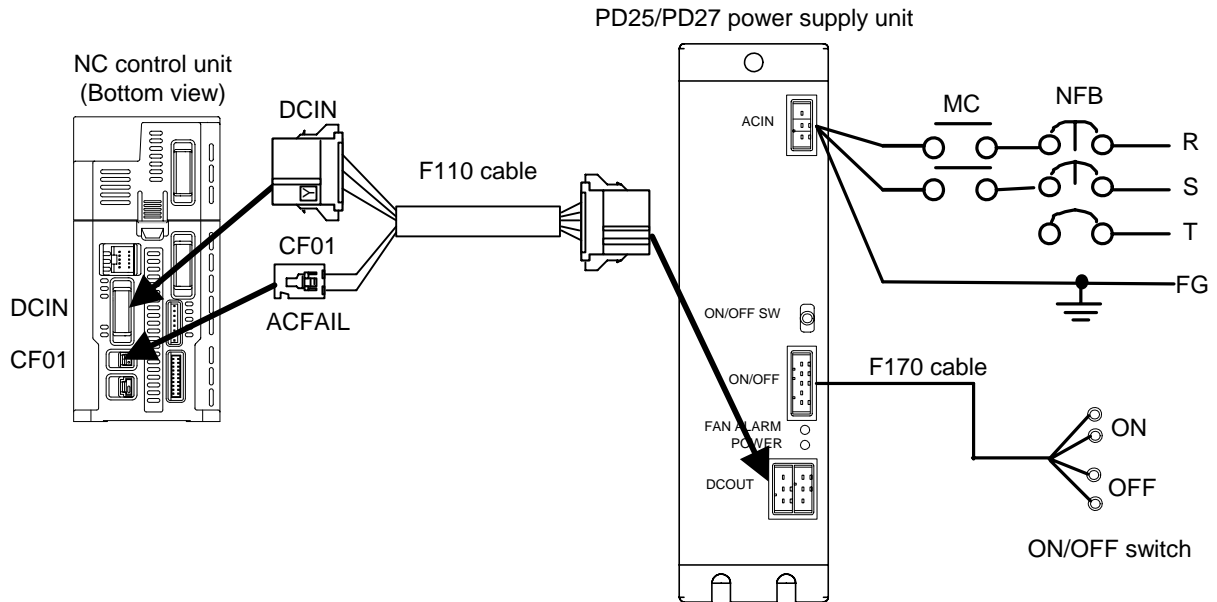

<Related items>

Cable drawing: "Appendix 2 (F110 cable, F170 cable)"

Connector pin assignment: "Appendix 3 (DCIN connector, CF01 connector)"

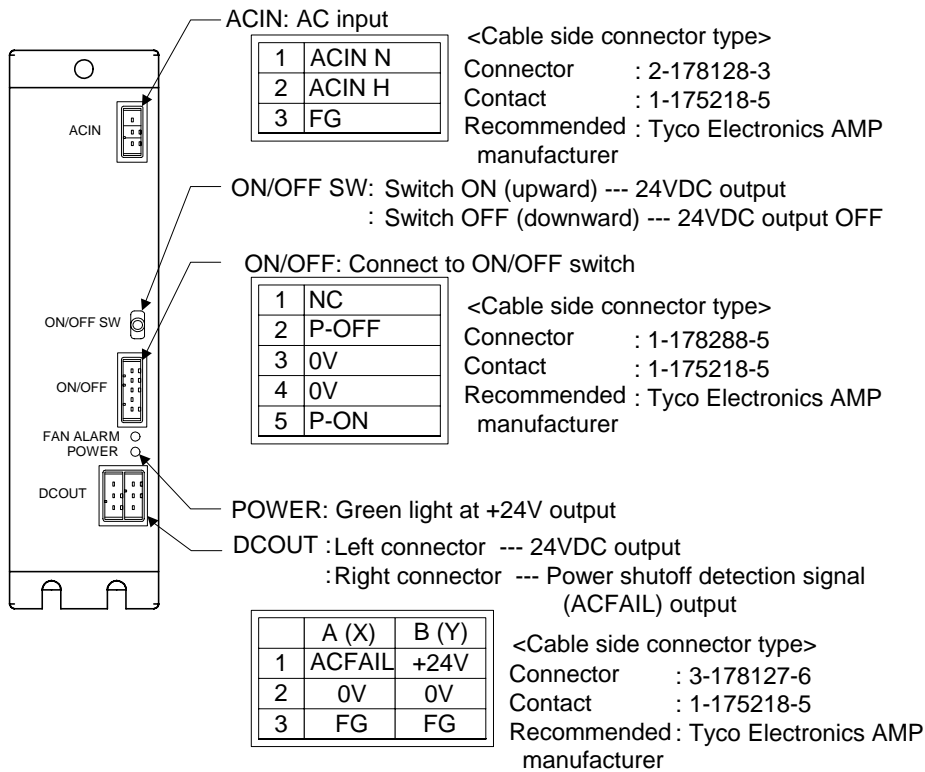

<Related items>

Connector pin assignment: "Appendix 3 (ACIN connector, ON/OFF connector, DCOUT connector)"

(2) Specifications of PD25/PD27 power supply

Item	PD25	PD27
Input power voltage	200V to 230VAC +10%-15% 50/60Hz ± 1Hz	200V to 480VAC +10%-15% 50/60Hz ± 3Hz
Output current	3A	8A
Dimension	130mm x 65mm x 230mm	170mm x 65mm x 230mm
Mass	1.5kg	2.5kg
Output holding time	300ms	300ms

**(Note)** PD25/PD27 cannot be turned ON immediately after it is turned OFF. Wait at least 2 seconds, and then turn the power ON.

### 6.3 Connecting with Operation Panel I/O Unit

Connect operation panel I/O unit to the connector OPI.

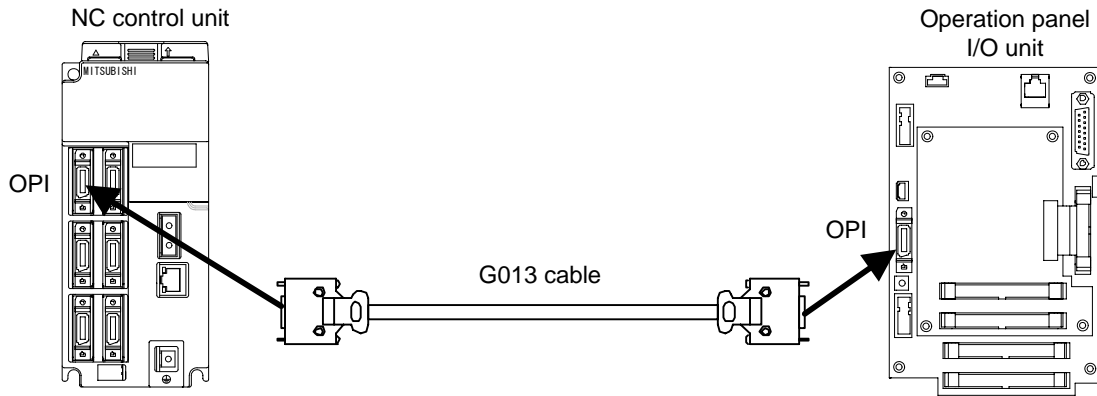

**(Note)** When not using operation panel I/O unit, place terminator E-TM on the OPI connector. If nothing is connected to the OPI connector, emergency stop will be applied. (Even if operation panel I/O unit is connected, if the unit's power is OFF, emergency stop will be applied.)

6.4 Connecting with Remote I/O Unit

Connect remote I/O unit to the connector RIO1, RIO2.  
 For the details on remote I/O, refer to the section "8.2. Connecting with Remote I/O Unit".

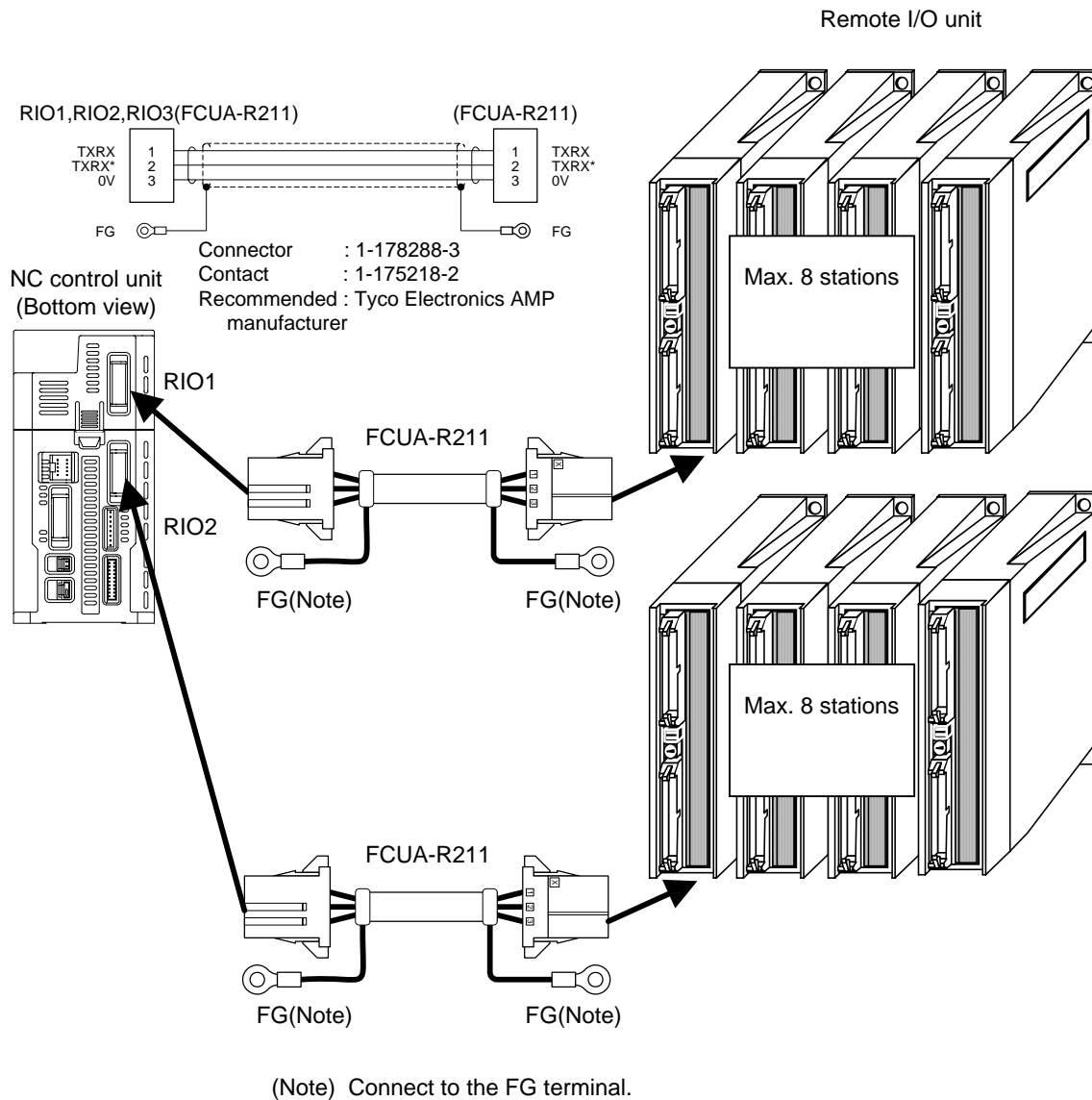

<Related items>

- Cable drawing: "Appendix 2 (FCUA-R211 cable)"
- Connector pin assignment: "Appendix 3 (RIO connector)"

6.5 Connecting with Scan I/O Card and Card-sized I/O Card

Refer to the section "8.3 Connecting with Scan I/O Card" and "8.4 Connecting with Card-sized I/O Card" for the connection of scan I/O card and card-sized I/O card to the control unit.

## 6.6 Connecting with Optical Communication Servo Drive Unit

(1) Connect servo drive unit MDS-D/DH series and MDS-D-SVJ3/SPJ3 series to the connector OPT1.

For the details on servo drive unit, refer to the following section and manuals:

"10. Basic Wiring for Servo Drive Unit"

"MDS-D Series Specifications Manual IB-1500011(ENG)"

"MDS-DH Series Specifications Manual IB-1500003(ENG)"

"MDS-D/DH Series Instruction Manual IB-1500025(ENG)"

"MDS-D-SVJ3/SPJ3 Series Specifications Manual IB-1500158(ENG)"

"MDS-D-SVJ3/SPJ3 Series Instruction Manual IB-1500193(ENG)"

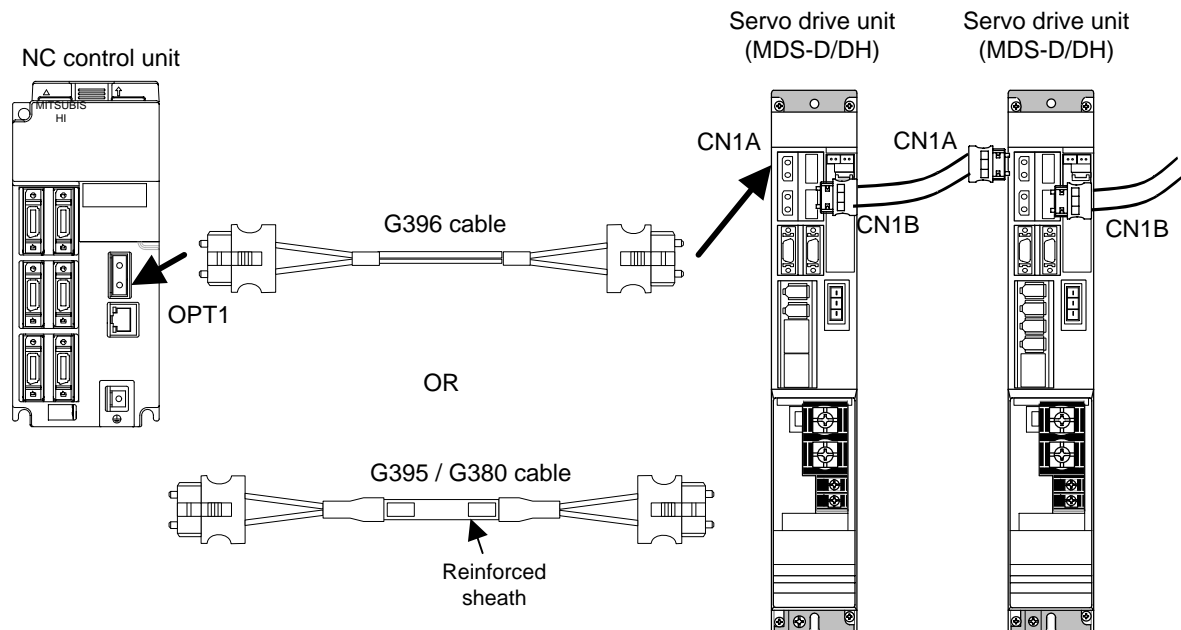

**(Note 1)** Binding the cables too tight with tie-wraps could result in an increased loss or a disconnection. Use a cushioning material such as sponge or rubber when bundling the cables and fix so that the cables do not move.

Recommended clamp material: CKN-13SP KITAGAWA INDUSTRIES

**(Note 2)** Never bundle the cables with vinyl tape. The plasticizing material in the vinyl tape could cause the cable reinforced sheath section to break.



## 6. Connections of Control Unit

### 6.6 Connecting with Optical Communication Servo Drive Unit

**(Note 3)** Loop the excessive cable with twice or more than the minimum bending radius.

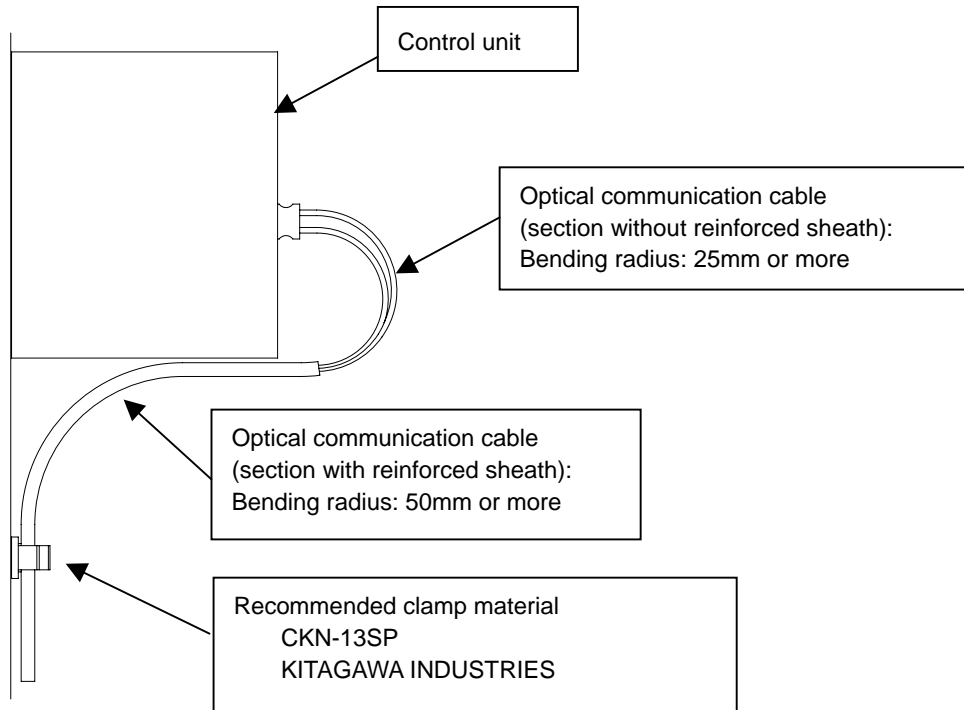

#### <Related items>

Cable drawing: "Appendix 2 (G380 Cable, G395 Cable, G396 Cable)"

Connector pin assignment: "Appendix 3 (OPT1 connector)"

#### (2) Criteria for optical cable selection

##### <G396 Cable>

Wire material : Optical communication cable POF type (Core: Plastic)  
Application : Use when wiring a cable of 10m or less inside the panel.  
Min. bending radius :

Cable	Minimum bending radius
2-core parallel cord	30mm or more

##### <G395 Cable>

Wire material : Optical communication cable POF type (Core: Plastic)  
Application : Use when wiring a cable of 10m or less outside the panel.  
Min. bending radius :

Cable	Minimum bending radius
2-core cable (section with reinforced sheath)	50mm or more
2-core cable (section without reinforced sheath)	30mm or more

##### <G380 Cable>

Wire material : Optical communication cable PCF type (Core: Glass)  
Application : Use when the cable length is 10m or more to 20m or less.  
Min. bending radius :

Cable	Minimum bending radius
2-core cable (section with reinforced sheath)	50mm or more
2-core cable (section without reinforced sheath)	25mm or more

## 6. Connections of Control Unit

### 6.7 Connecting with Auxiliary Axis Servo Drive Unit: MR-J2-CT

#### 6.7 Connecting with Auxiliary Axis Servo Drive Unit: MR-J2-CT

(1) Connect auxiliary axis servo drive unit MR-J2-CT to the connector SV1, SV2.

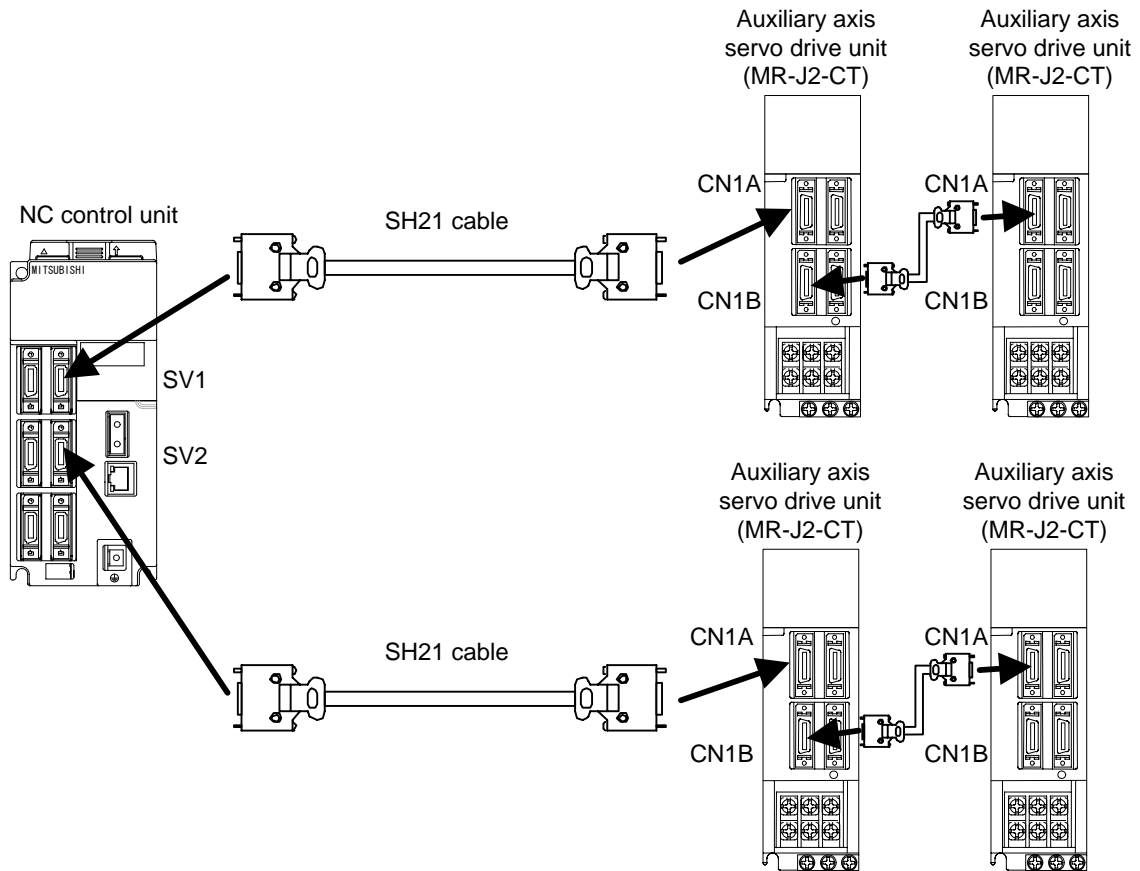

#### <Related items>

Cable drawing: "Appendix 2 (SH21 Cable)"

Connector pin assignment: "Appendix 3 (SV1 connector, SV2 connector)"

6.8 Connecting with Expansion Unit

6.8.1 Connecting with I/O Device Using PROFIBUS-DP

This unit functions as the PROFIBUS-DP master station.

In order to connect with I/O device by using PROFIBUS-DP, expansion unit (FCU7-EX891) and PROFIBUS-DP unit (FCU7-HN571) are required. Mount the expansion unit on the right side of the control unit and PROFIBUS-DP unit in the expansion unit slot.

Use dedicated cable for the PROFIBUS-DP and connect to the NET connector.

When installed at the end of the network, turn the terminator slide switch ON. In all the others cases, the switch must be turned OFF.

When setting parameters in the PROFIBUS-DP unit by using configuration software (parameter setting tool), connect PROFIBUS-DP unit and personal computer (PC/AT compatible) with RS-232C cross cable. At this time, configuration software must be installed in the personal computer.

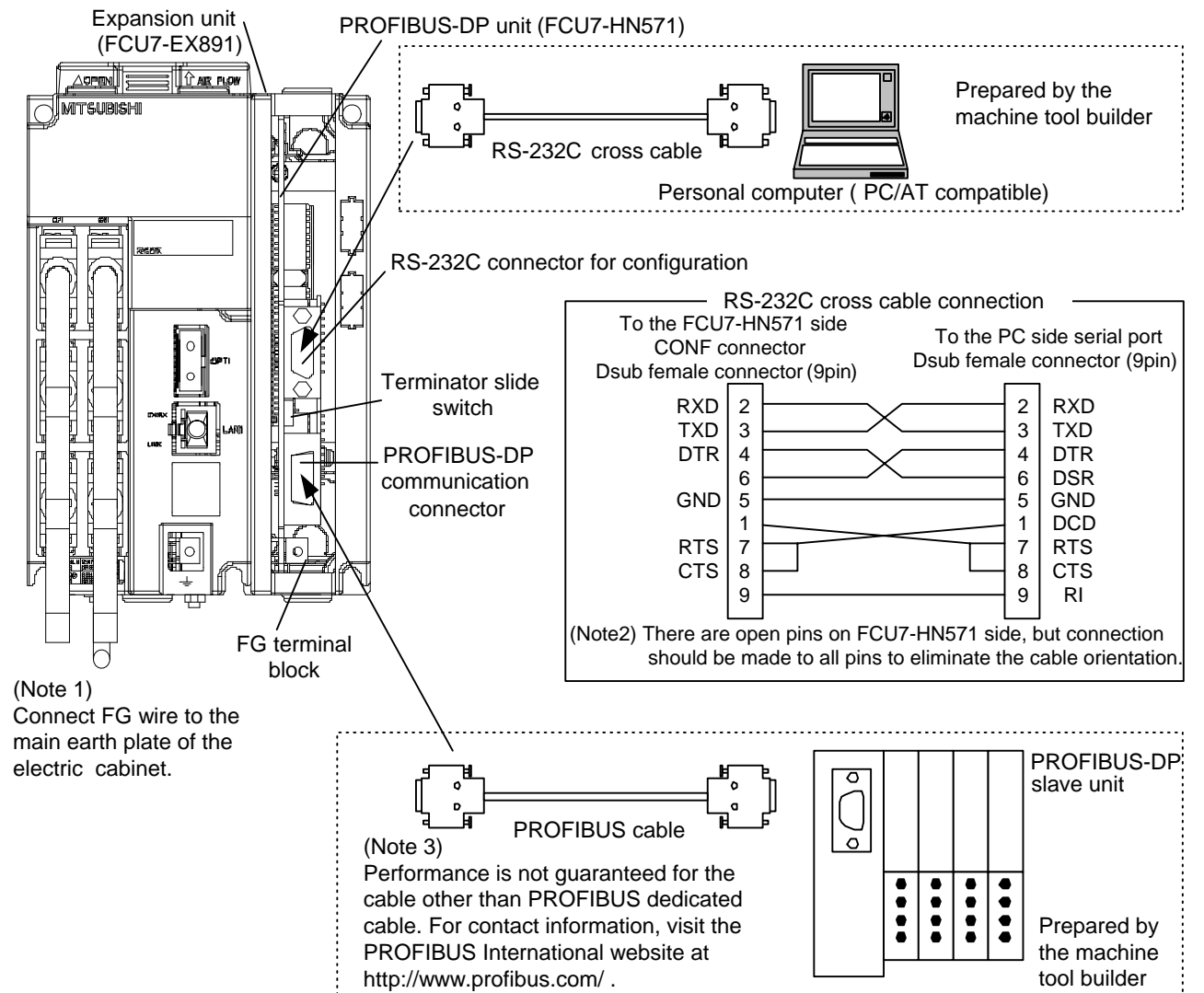

For the inquiries related to configuration software, contact:

Hilscher Gesellschaft für Systemautomation mbH  
 Rheinstraße 78  
 D-65795 Hattersheim Germany  
 TEL: +49-6190-9907-0 FAX: +49-6190-9907-50

6.8.2 Expanding Optical Servo Communication I/F

Usually, control unit OPT1 connector is used for optical servo communication I/F.

For expanding optical servo communication I/F, an expansion unit (FCU7-EX891) and an optical servo communication I/F unit are required. Mount an expansion unit onto the right side of the control unit, and then place an optical communication I/F unit into the expansion unit slot.

There are two types of optical servo communication I/F units available.

- FCU7-HN551 (For 1ch expansion)
- FCU7-HN552 (For 2ch expansion)

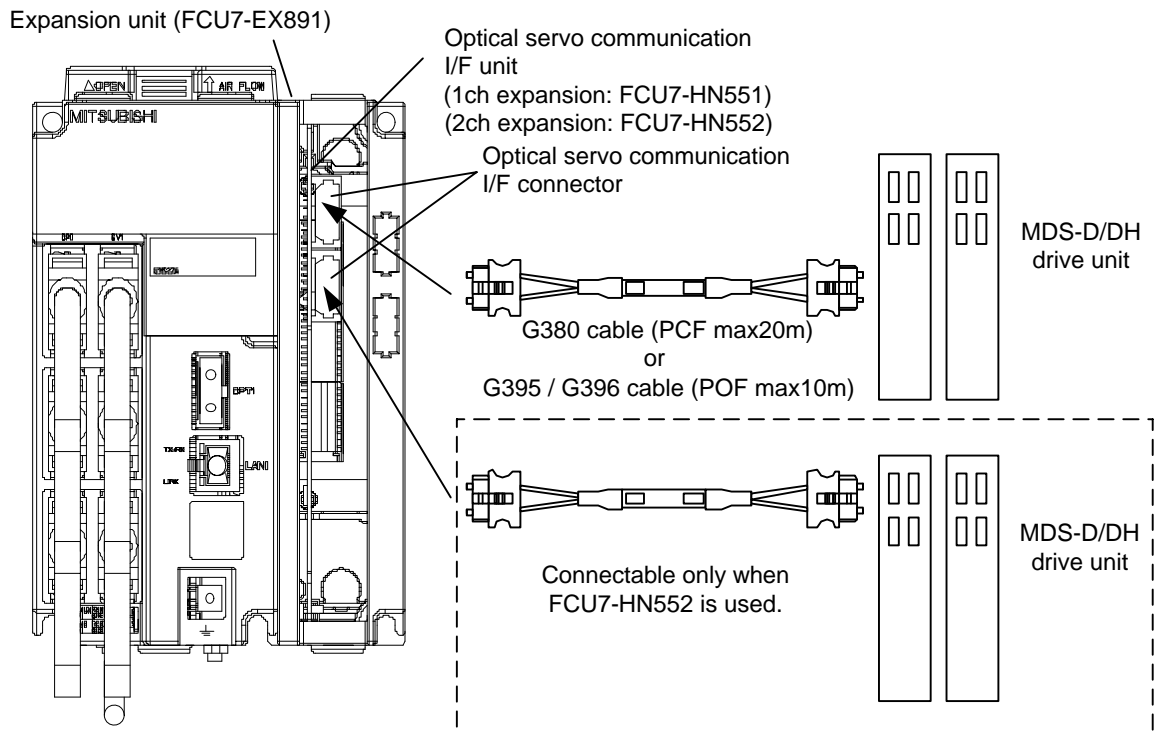

## 6.8.3 Connecting I/O Devices via CC-Link

CC-Link unit works as master station or local station of CC-Link (Ver.2 mode).

Expansion unit (FCU7-EX891) and CC-Link unit (FCU7-HN576) are required to connect I/O devices via CC-Link. Mount the expansion unit on the right side of the control unit, and install the CC-Link unit in the slot of the expansion unit.

CC-Link uses the dedicated cable. Connect the cable to the terminal block provided with the CC-Link unit. Make sure to attach the terminator, provided with the CC-Link unit, to the final station unit.

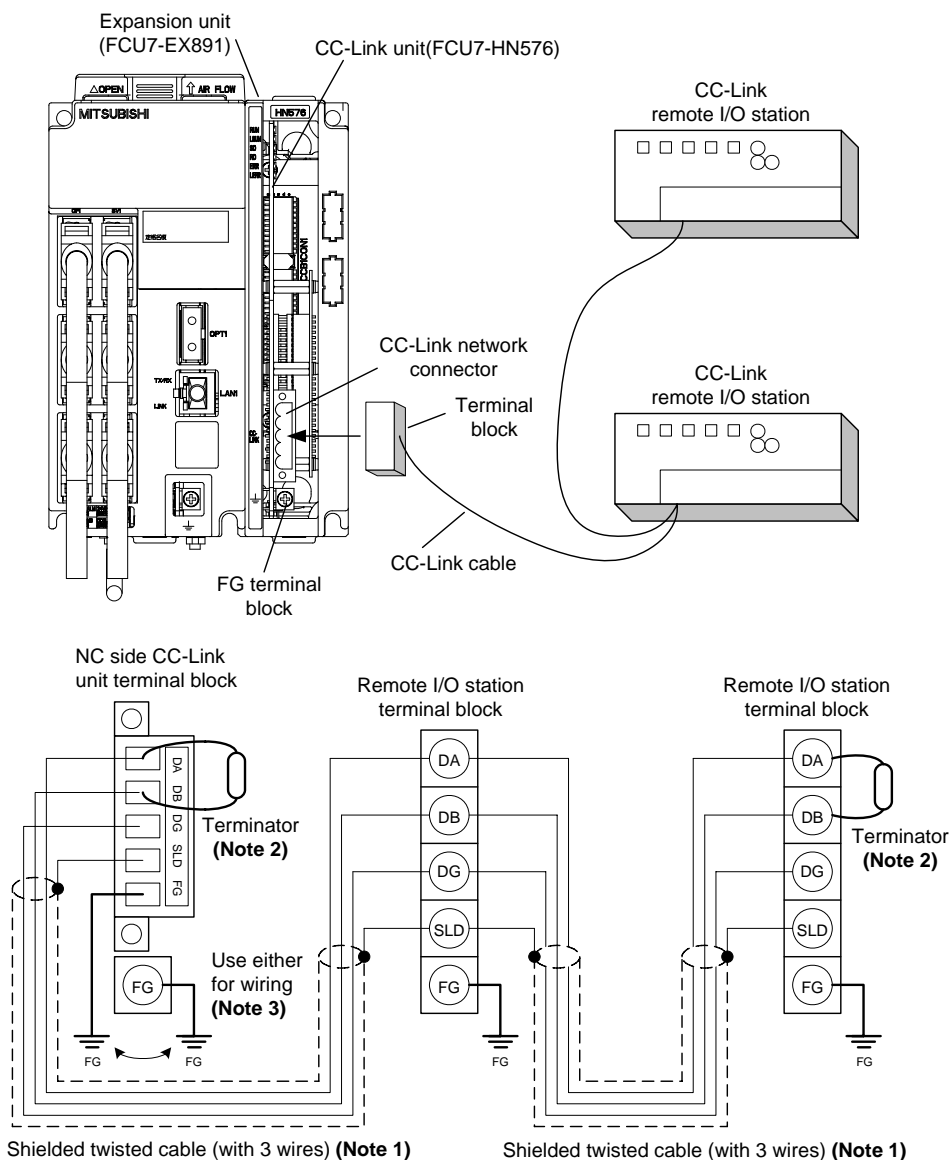

- (Note 1)** Unless the CC-Link dedicated cable is used, CC-Link system does not guarantee its operation. For the specifications of the CC-Link dedicated cable and the inquiries, see the homepage of the CC-Link Partner Association (<http://www.cc-link.org/>). (Click "Product Information".)
- (Note 2)** Use the terminator provided with the CC-Link unit. The value of the terminator depends on the cable used: 110Ω when the CC-Link dedicated cable is used, 130Ω when the CC-Link dedicated high performance cable is used.
- (Note 3)** Use either the FG terminal on the NC side CC-Link terminal block or the FG terminal block just below the CC-Link terminal block to connect to the ground of the electric cabinet.

Wiring the cables to the CC-Link terminal block

- (1) Remove the sheath of the cable and isolate each internal wire from the shield mesh.
- (2) Remove the shield mesh and the coat of each internal wire. Twist the core wires.

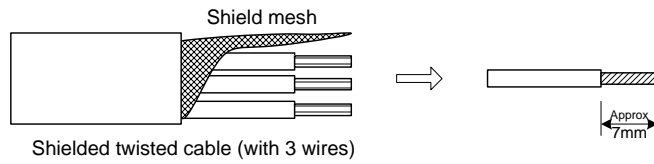

- (3) In the intermediate station, twist together the same wires or the shield meshes of the cables from/to the previous/next station.
- (4) In the final station, process the provided terminator as follows to attach to the station.

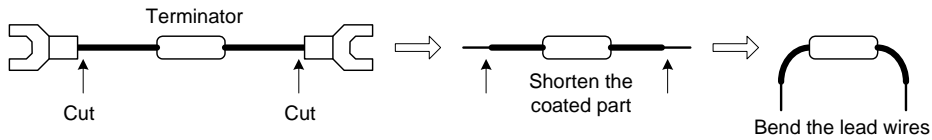

- (5) Insert the core wire into the opening of the terminal block. Hold the wire tight with a flat-blade screwdriver. Check the screws on the terminal are loose enough before inserting the wires into the openings.

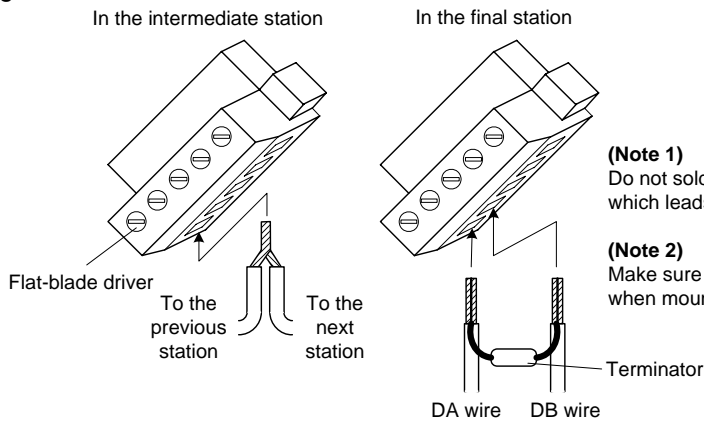

**(Note 1)**  
Do not solder-plate the core wire, which leads a defective cable contact.

**(Note 2)**  
Make sure the lead wires are kept inserted when mounting the terminator.

- (6) After wiring cables to the terminal block, mount the terminal block into the CC-Link connector and fix it with a flat-blade screwdriver.

6.9 Connecting with RS-232C Device

(1) Connect RS-232C device to the connector SIO.

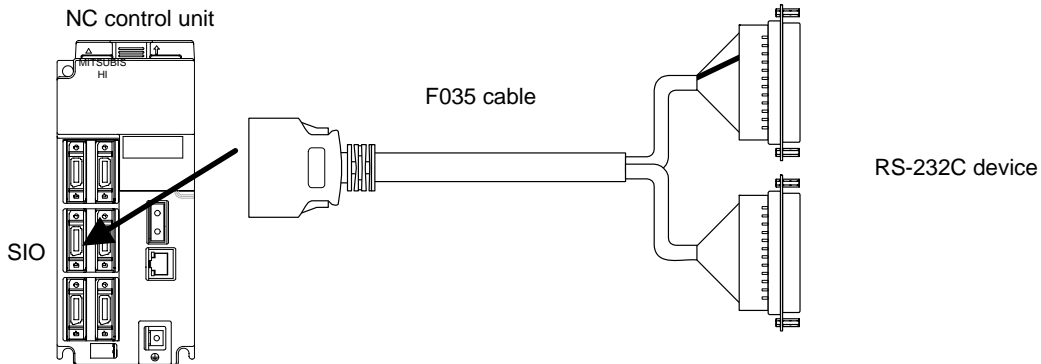

Cable name	1ch	2ch
F034 cable	○	
F035 cable	○	○

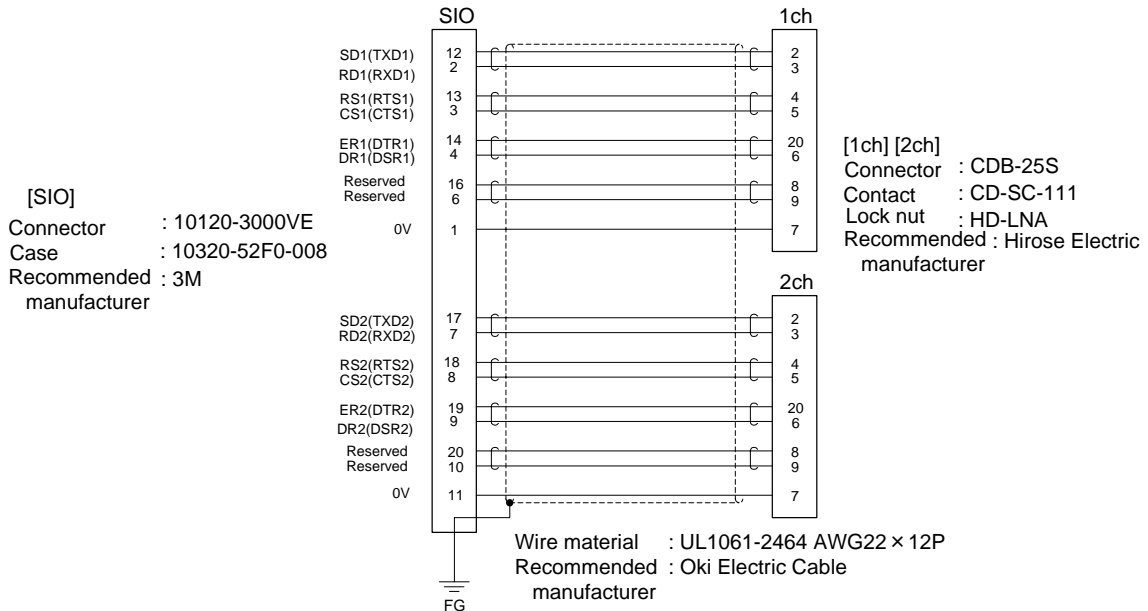

**(Note)** Please be aware that the wiring of serial communication cable (G031/G032 cable) for a display unit differs.

<Related items>

Cable drawing: "Appendix 2 (F034/F035 Cable)"

Connector pin assignment: "Appendix 3 (SIO-NC connector)"

(2) Example of wiring connections to the RS-232C device

When connecting to the RS-232C device, refer to the following diagrams and cross the wiring for the transmission signals.

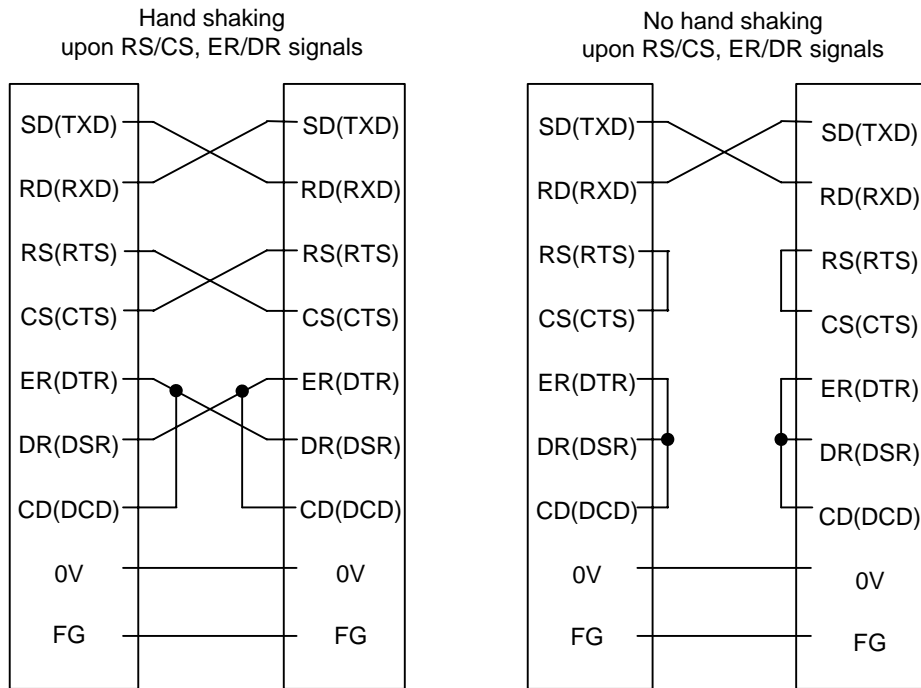



### 6.10 Connecting with Skip Signal (Sensor)

Connect skip signal to the connector SKIP.

Skip signal is used for processing the high-speed signals. Always shield the cable.

(1) Connection of skip signal cable

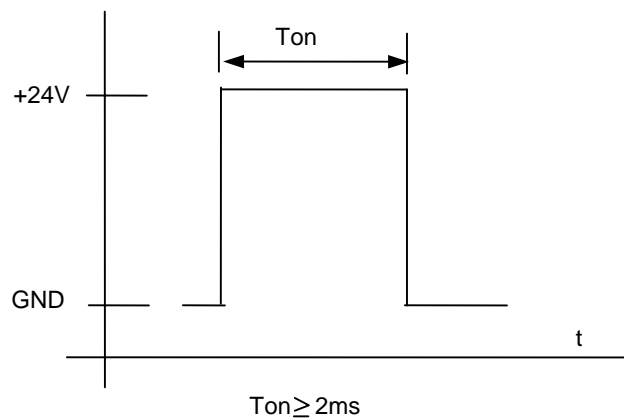
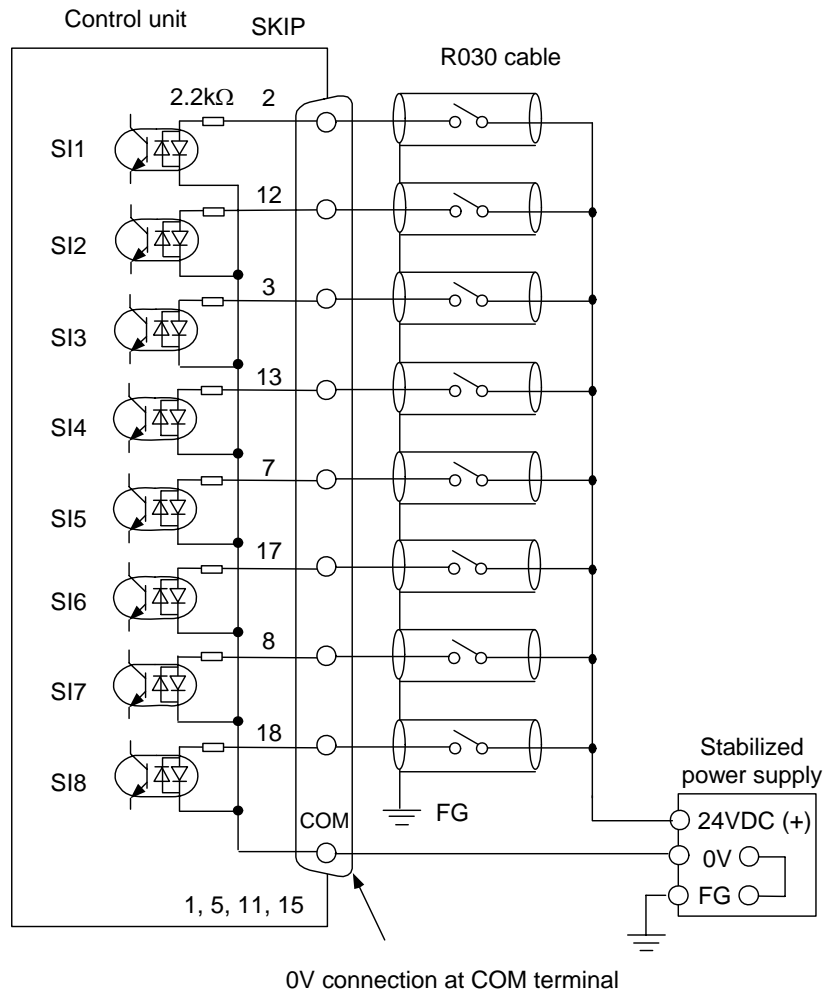

**(Note 1)** NC recognizes input signals of 2ms or more as the valid skip signals. If machine contacts (relay, etc.) are used, malfunctions will occur due to chattering. Use semiconductor contacts (transistor, etc.).

**(Note 2)** Fold the cable shield over the sheath, and wrap copper foil tape over it. Connect the wound copper foil tape to GND plate of the connector.

## (2) Skip signal input conditions

The input signals must be used within the following condition ranges.

Input voltage at external contact ON	18V or more, 25.2V or less
Input current at external contact ON	6mA or more
Input voltage at external contact OFF	4V or less
Input current at external contact OFF	2mA or less
Input signal holding time (Ton)	2ms or more
Machine side contact capacity	30V or more, 16mA or more

**<Related items>**

Cable drawing: "Appendix 2 (FCUA-R030 cable)"

Connector pin assignment: "Appendix 3 (SKIP connector)"

## 6. Connections of Control Unit

### 6.11 Connecting with Synchronous Feed Encoder/Manual Pulse Generator

#### 6.11 Connecting with Synchronous Feed Encoder/Manual Pulse Generator

Synchronous feed encoder (1ch) or 5V power supply type manual pulse generator (2ch) can be connected.

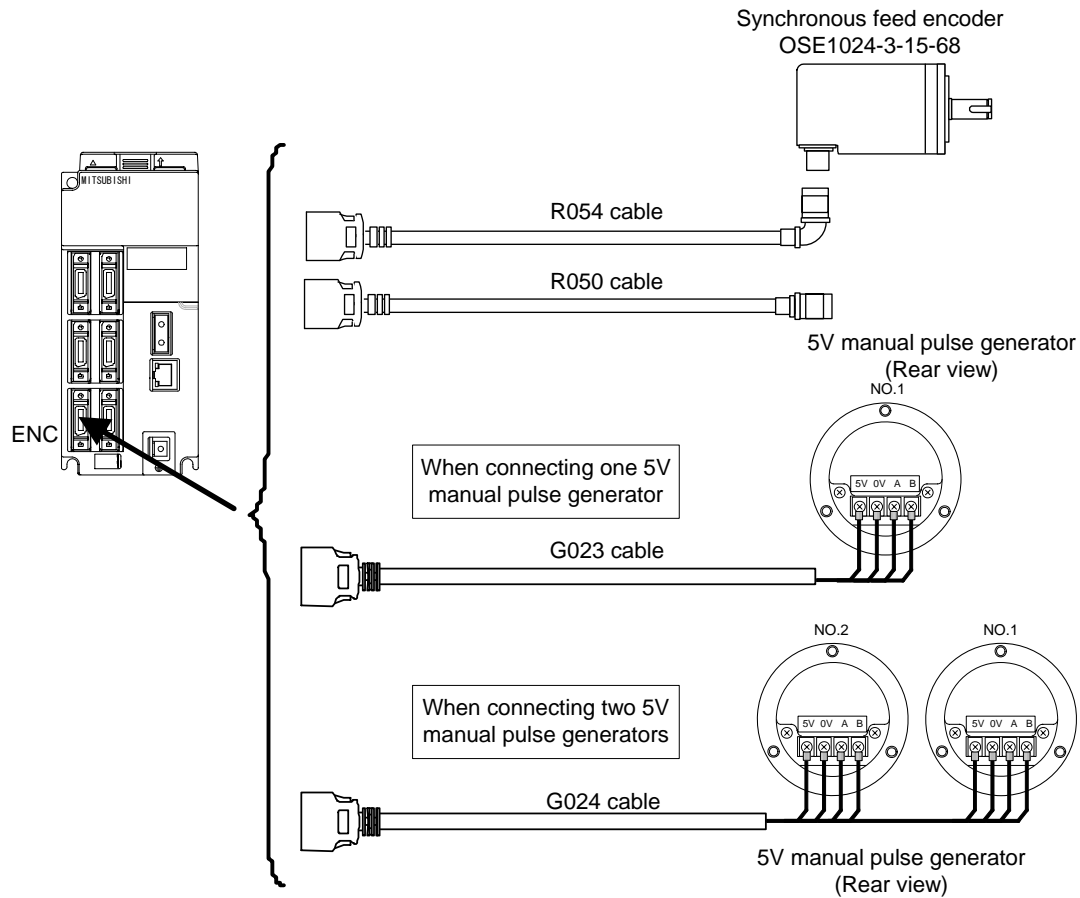

#### <Related items>

Cable drawing: "Appendix 2 (FCUA-R050/R054 Cable, G023/G024)"

Connector pin assignment: "Appendix 3 (ENC connector)"

Refer to the section "7.6.2 Connecting with 5V Manual Pulse Generator" for 5V manual pulse generator's input conditions and input/output circuit example.

When using synchronous feed encoder and manual pulse generator at the same time, the cables must be prepared by the machine tool builder.

### 6.12 Connections of Emergency Stop Signal

(1) When not using control unit side emergency stop input signal (EMG)

When not using control unit side emergency stop input signal, such as when operation panel I/O unit side emergency stop input signal (EMG) is used, invalidate the input signal by using terminal cable G123. G123 cable comes with the control unit.

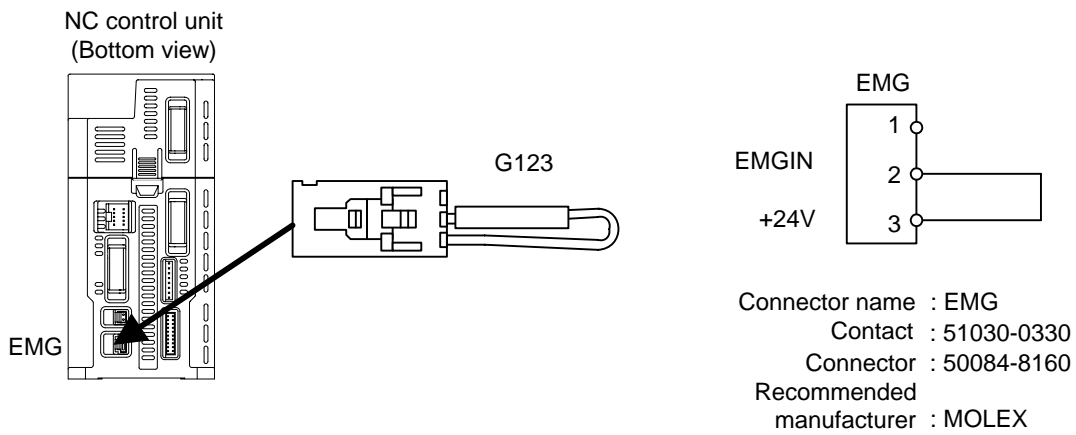

(2) When using control unit side emergency stop input signal (EMG)

When using control unit side emergency stop input signal (EMG), connect to the emergency stop switch by using F120 cable.

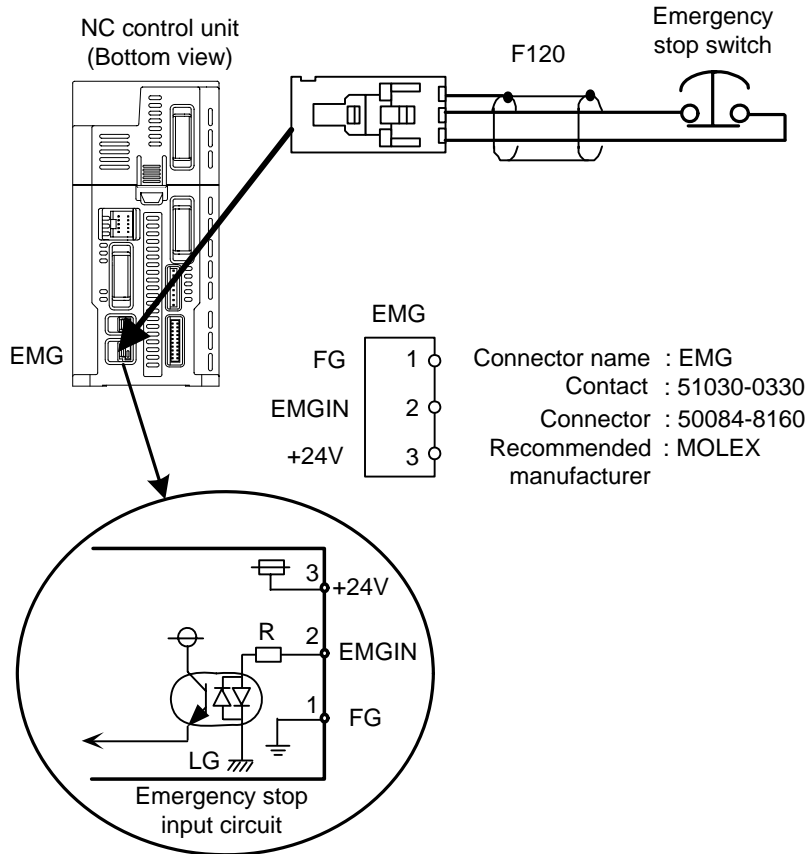

**(Note1)** When installing emergency stop switch at operation panel and electric cabinet each, both emergency stop input signals (EMG), the signal at the operating panel I/O unit side and at the control unit side, can be used.

**(Note2)** Emergency stop is compliant to the stop category 1 of the European Safety Standards "EN60204-1".

<Related items>

Cable drawing: "Appendix 2 (F120 Cable, G123 Cable)"



## 6. Connections of Control Unit

### 6.13 Connecting with Safety Observing I/O Device: SDIO Connector

Safety standards taken into consideration

(a) 98/37/EC Machinery directive

(b) EN954-1:1996 Safety of machine – Safety-related parts of control system Part1:  
General principles for design

(c) EN60204-1/1997 Safety of machine – Electrical equipment of machines; Part 1: General requirements

#### (2) Specifications of SDIO connector

<Cable side connector>

Type: 51353-1000

Contact type: 56134-9000

Recommended

manufacturer: MOLEX

<Wire material>

Type: UL1061-2464 AWG22

Recommended

manufacturer: Oki Electric Cable

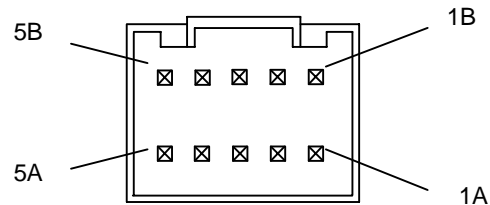

SDIO connector pin assignment

#### Description of SDIO connector terminal

Pin	I/O	Function	Pin	I/O	Function
1A	COM	Sink (common 24V) Source (common 0V)	1B		RG (GND for DO 24V power supply)
2A	I	SDI1 (Door 1 switch input)	2B	I	SDI2 (Door 2 switch input)
3A		Reserved (Not connected)	3B		Reserved (Not connected)
4A		24VDC (DO power supply)	4B	O	SDO1 (Contactor control output)
5A		Reserved (Not connected)	5B		Reserved (Not connected)

Pin	Characteristic	Voltage	Current	Description
SDI1 to 2	Input	Refer to description		Sink input signal: 0v COM: 24V Source input signal: 24v COM: 0V
SDO1	Output	24V	Max. 60mA	Contactor shutoff signal output. (Note) Output voltage or output current may not be sufficient enough to directly control contactor. In such a case, use a relay that operates under 24VDC, 60mA, etc. between control unit and contactor.

## 6. Connections of Control Unit

### 6.13 Connecting with Safety Observing I/O Device: SDIO Connector

#### (3) SDIO connector cable

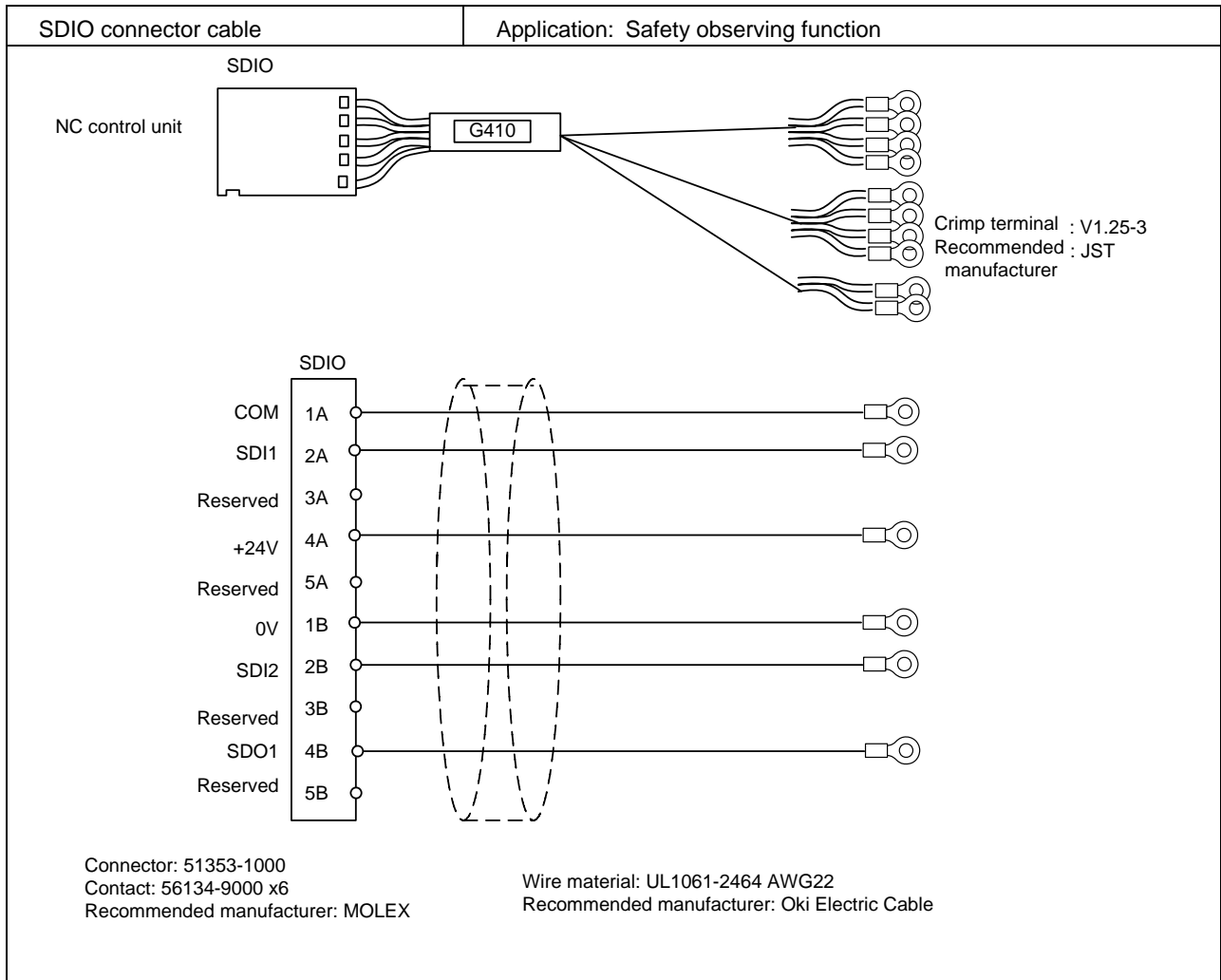

**(Note)** This cable must be prepared by the machine tool builder.



### 7. Connections of Operation Panel I/O Unit

#### <Characteristics>

The wirings between operation panel and electric cabinet (or control panel) can be simplified by putting I/O interfaces around the operation panel together.

Characteristics of operation panel I/O unit are as follows.

- (1) Operation panel (display unit section) and electric cabinet (control unit section) can be wired with one cable (G013).  
This is effective to simplify the wiring between operation panel and electric cabinet, as well as to reduce the cost of wiring.  
G013 cable includes RI03, EMG and LAN.
- (2) Number of DI/DO points that can be mounted on the machine operation panel is 32/32 as standard and 64/64 at the maximum.  
Both sink type and source type are available.
- (3) Remote I/O interface --- 1ch  
Remote I/O unit, card-sized I/O card, scan I/O card, etc. can be extended up to 5 channels.  
Note that the following (a) and (b) will be applied if DI/DO mounted on the operation panel I/O unit is used.  
(a) When 32 points/32 points are used, up to 5 channels, or 160 points/160 points in total, are available.  
(b) When 64 points/64 points are used, up to 4 channels, or 128 points/128 points in total, are available.
- (4) Manual pulse generator --- 3ch  
5V and 12V manual pulse generators can be connected.
- (5) Emergency stop input --- 1ch  
Emergency stop switch installed on the operation panel can be connected.
- (6) LAN communication interface --- 1ch  
Display unit can be connected.
- (7) NC reset interface --- 1ch  
NC can be reset by DI input. NC reset interface is connected to the keyboard unit.
- (8) Installation on the back side of the keyboard unit is possible.  
Allows space saving inside the operation panel.

**(Note)** Operation panel I/O unit is attached to the back side of the keyboard unit when shipped. (This applies only when purchasing operation panel I/O unit and the keyboard unit together.)

## 7. Connections of Operation Panel I/O Unit

### 7.1 Operation Panel I/O Unit Connection System Drawing

#### 7.1 Operation Panel I/O Unit Connection System Drawing

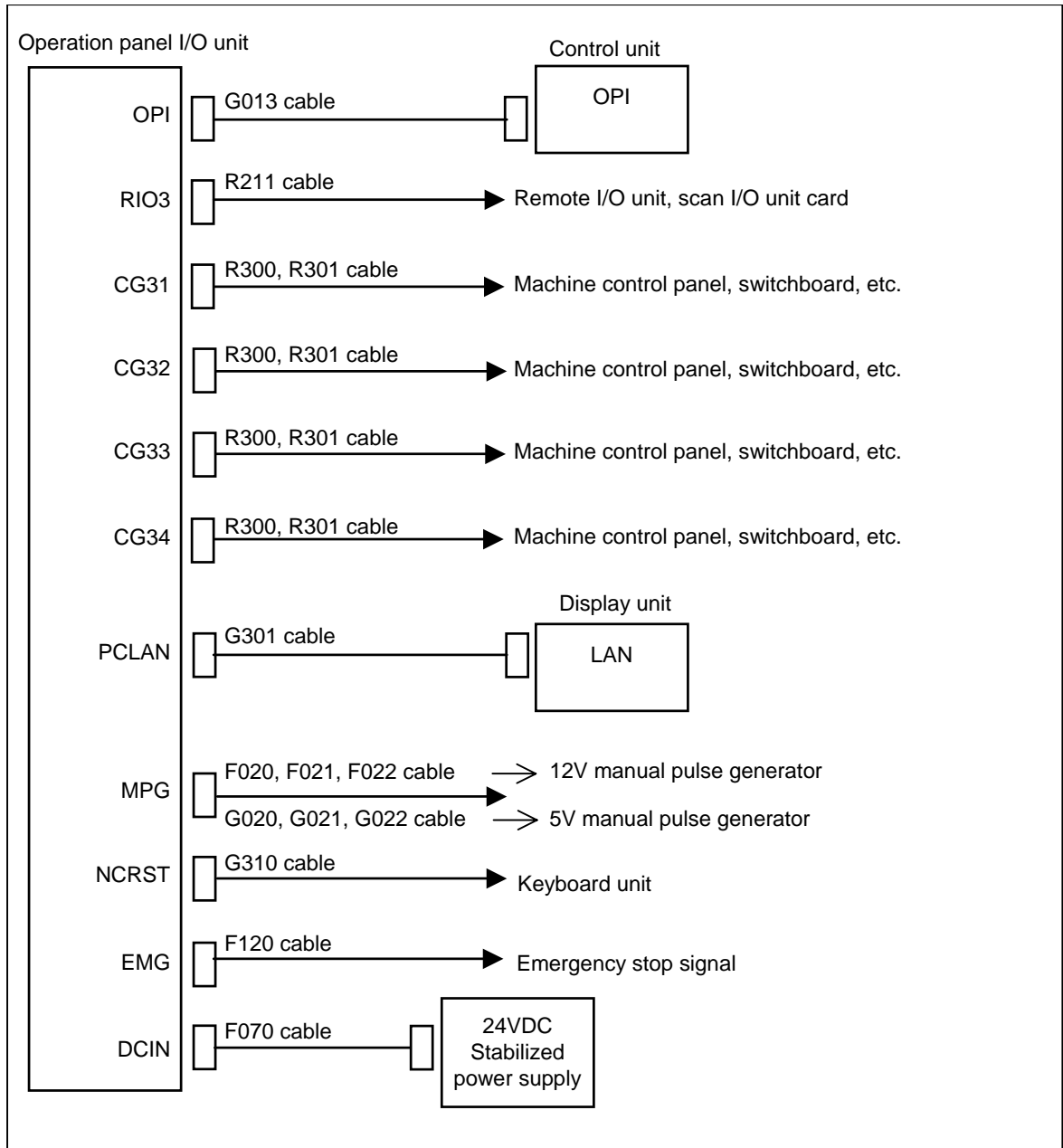

## 7.2 Connecting with Power Supply

Connect 24VDC power supply (general-purpose stabilized power supply) to the operation panel I/O unit.

### (1) Connection of power supply

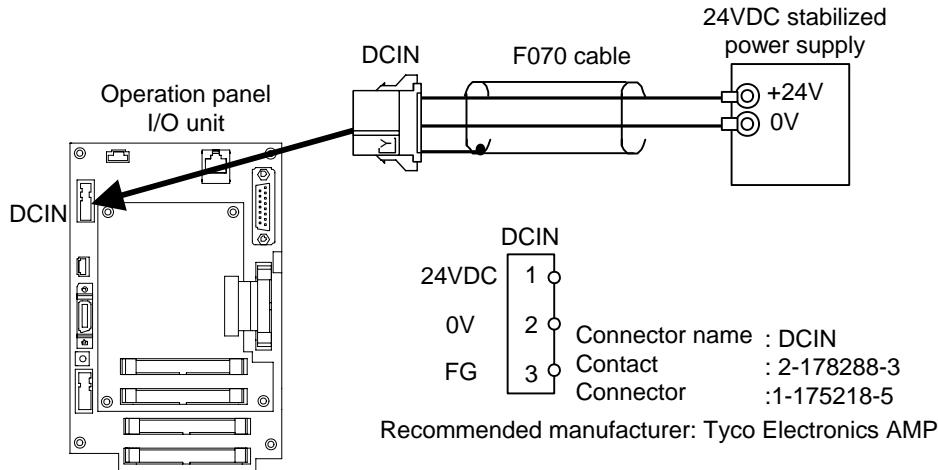

**(Note)** Install the ferrite core that comes with the operation panel I/O unit on the F070 cable.  
Refer to the section "Appendix 5.5 Ferrite Core Installation Method" for details.

#### <Related items>

Cable drawing: "Appendix 2 (F070 cable)"

Connector pin assignment: "Appendix 3 (DCIN connector)"

### (2) Specifications of power supply

When selecting the stabilized power supply (prepared by machine tool builder), consider the characteristics indicated in the section "6.2.1 When Using General-Purpose 24VDC Stabilized Power Supply". Use a power supply that complies with CE Marking or that follows the safety standards.

### 7.3 Connecting with Display Unit

Connect display unit to the connector PCLAN.

G301 cable (1m) comes with the operation panel I/O unit.

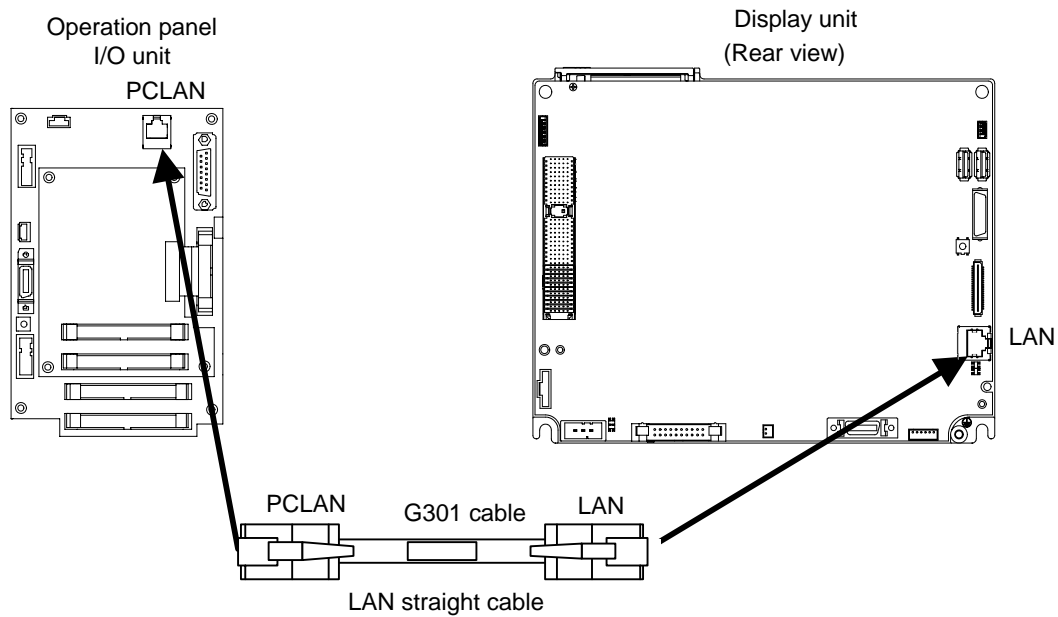

#### <Related items>

Cable drawing: "Appendix 2 (G301 cable)"

Connector pin assignment: "Appendix 3 (LAN connector)"

### 7.4 Connecting with Keyboard Unit

Connect keyboard unit to the connector NCRST.

G310 cable (10cm) comes with the operation panel I/O unit.

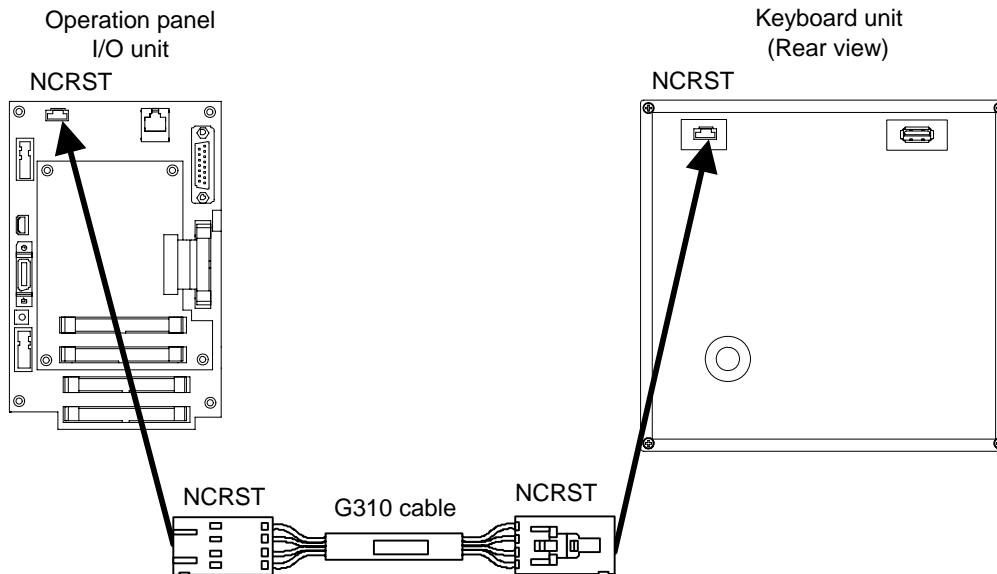

#### <Related items>

Cable drawing: "Appendix 2 (G310 cable)"

Connector pin assignment: "Appendix 3 (NCRST connector)"

7.5 Connections of Emergency Stop Signal

- (1) When using operation panel I/O unit side emergency stop input signal (EMG)  
 When using operation panel I/O unit side emergency stop input signal (EMG), use F120 cable to connect to the emergency stop switch.

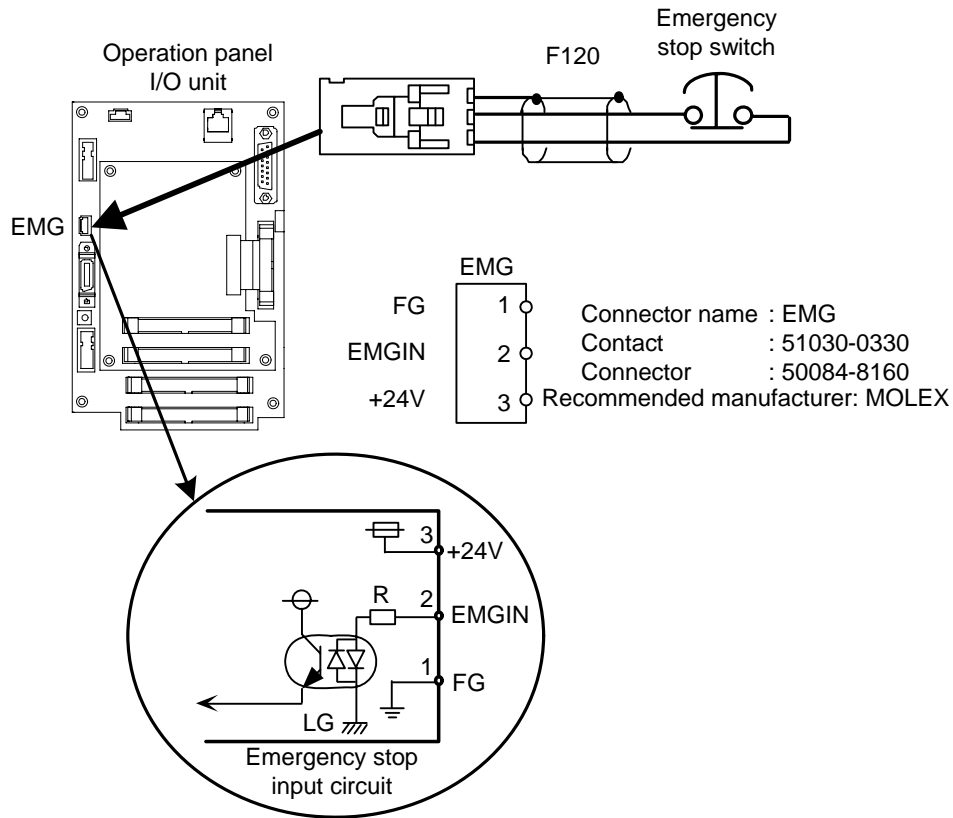

## 7. Connections of Operation Panel I/O Unit

### 7.5 Connections of Emergency Stop Signal

(2) When not using operation panel I/O unit side emergency stop input signal (EMG)

When not using operation panel I/O unit side emergency stop input signal (EMG), such as when control unit side emergency stop input signal (EMG) is used, invalidate the input signal by using terminal cable G123. Note that G123 cable does not come with the operation panel I/O unit.

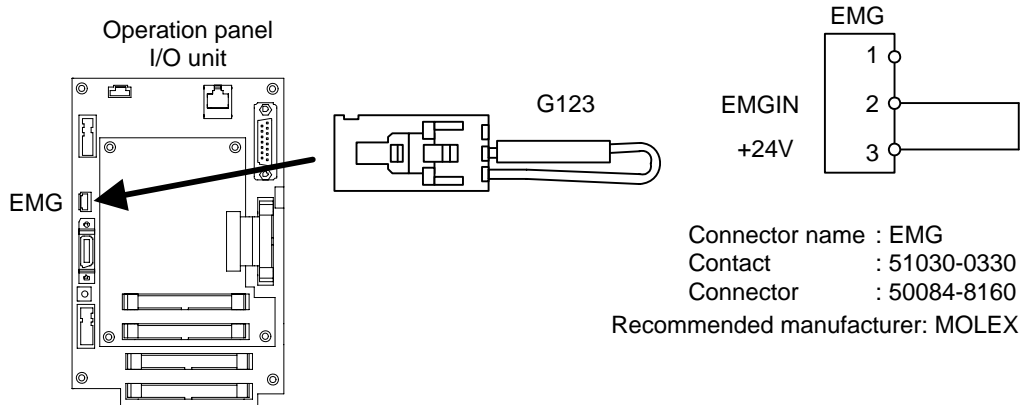

**(Note1)** When installing emergency stop switch at operation panel and electric cabinet each, both emergency stop input signals (EMG), the signal at the operating panel I/O unit side and at the control unit side, can be used.

**(Note2)** Emergency stop is compliant to the stop category 1 of the European Safety Standards "EN60204-1".

#### <Related items>

Cable drawing: "Appendix 2 (F120 Cable, G123 Cable)"

Connector pin assignment: "Appendix 3 (EMG connector)"

## 7. Connections of Operation Panel I/O Unit

### 7.6 Connecting with Manual Pulse Generator

#### 7.6 Connecting with Manual Pulse Generator

Both 5V power supply type (UFO-01-2Z9, etc.) and 12V power supply type (HD60, etc.) manual pulse generator can be used. Take the maximum cable length, etc. into consideration when selecting.

##### 7.6.1 Connecting with 12V Manual Pulse Generator (Maximum Cable Length: 50m)

Connect 12V manual pulse generator to the connector MPG.

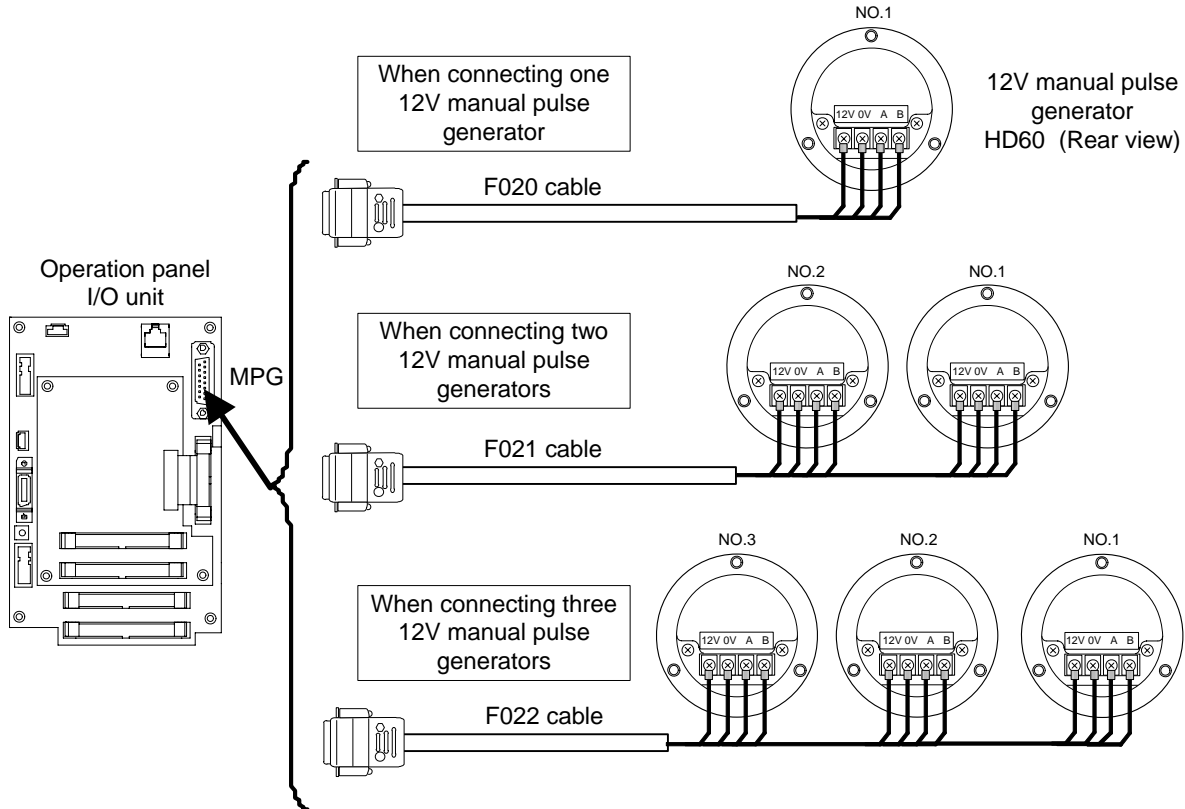

##### 12V manual pulse generator input conditions

Input pulse signal type	90° phase difference between A and B. (Refer to waveform below.)
Input signal voltage	H level 3.5V to 5.25V L level 0V to 0.5V
Max. input pulse frequency	100kHz
Power voltage for pulse generators	12VDC±10%
Max. output current	100mA
No. of pulses per rotation	25pulse/rev or 100pulse/rev

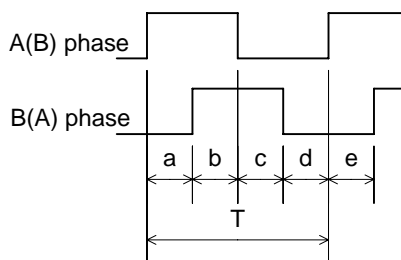

a.b.c.d.e.: A phase or B phase rising edge (falling edge) phase difference =  $T/4 \pm t/10$

T: A or B phase cycle (Min. 10μs)

(Note) When selecting a manual pulse generator, make sure that its case and 0V terminal are insulated.

##### 12V manual pulse generator input/output circuit

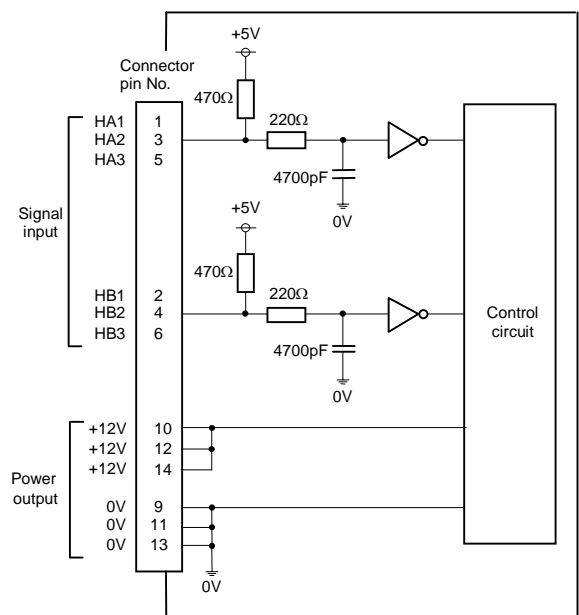



## 7. Connections of Operation Panel I/O Unit

### 7.6 Connecting with Manual Pulse Generator

#### 7.6.2 Connecting with 5V Manual Pulse Generator (Maximum Cable Length: 20m)

Connect 5V manual pulse generator to the connector MPG.

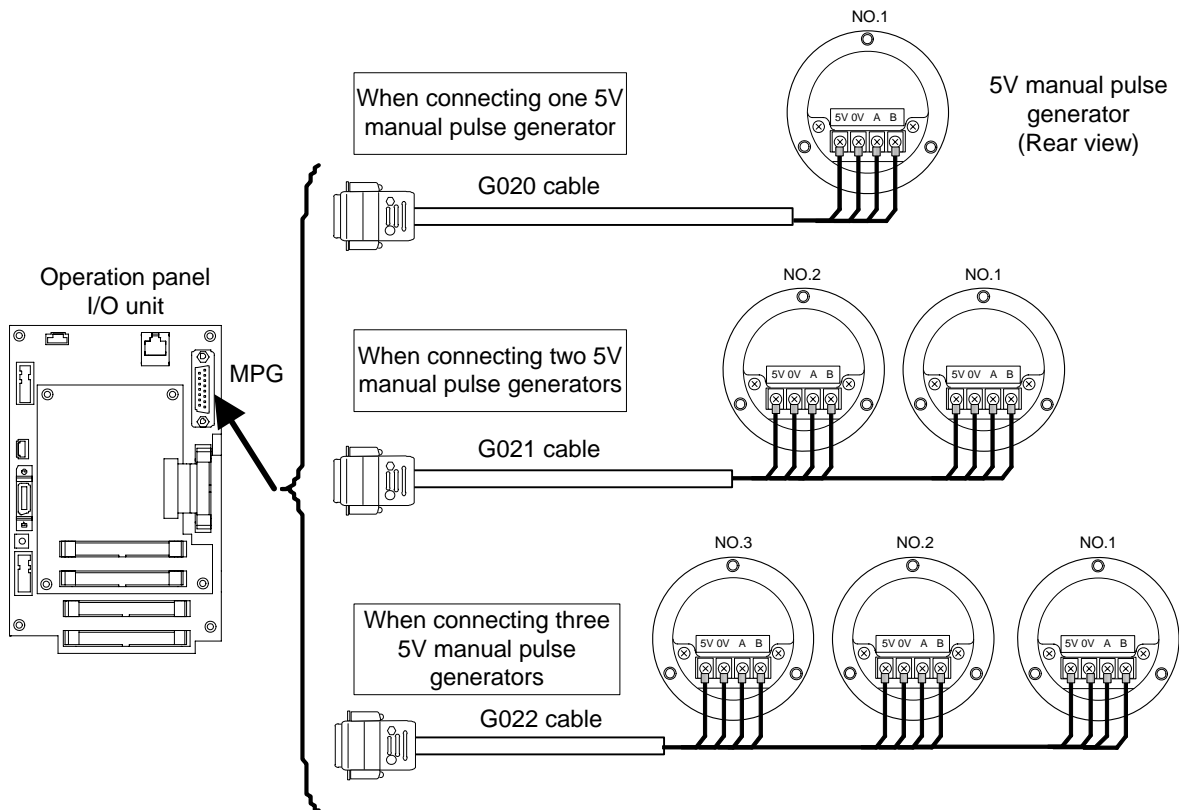

#### 5V manual pulse generator input conditions

Input pulse signal type	90° phase difference between A and B. (Refer to waveform below.)
Input signal voltage	H level 3.5V to 5.25V L level 0V to 0.5V
Max. input pulse frequency	100kHz
Power voltage for pulse generators	5VDC±10%
Max. output current	100mA
No. of pulses per rotation	25 pulse/rev or 100pulse/rev

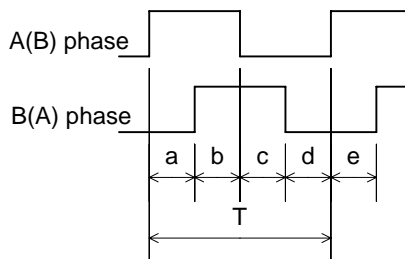

a.b.c.d.e.: A phase or B phase rising edge (falling edge) phase difference =  $T/4 \pm t/10$   
T: A or B phase cycle (Min. 10μs)

#### <Related items>

Cable drawing: "Appendix 2 (F020/F021/F022 cable, G020/G021/G022 cable)"

Connector pin assignment: "Appendix 3 (MPG connector)"

(Note) When selecting a manual pulse generator, make sure that its case and 0V terminal are insulated.

#### 5V manual pulse generator input/output circuit

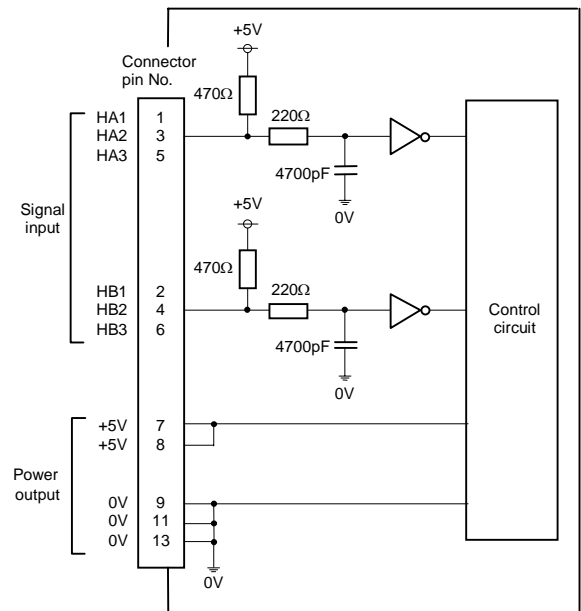

**7.7. Connecting with Remote I/O Unit**

Connect remote I/O unit to the connector RIO3.

(Note) When not connecting remote I/O unit, connect a terminator (R-TM) to the connector R103. R-TM terminator comes with operation panel I/O unit.

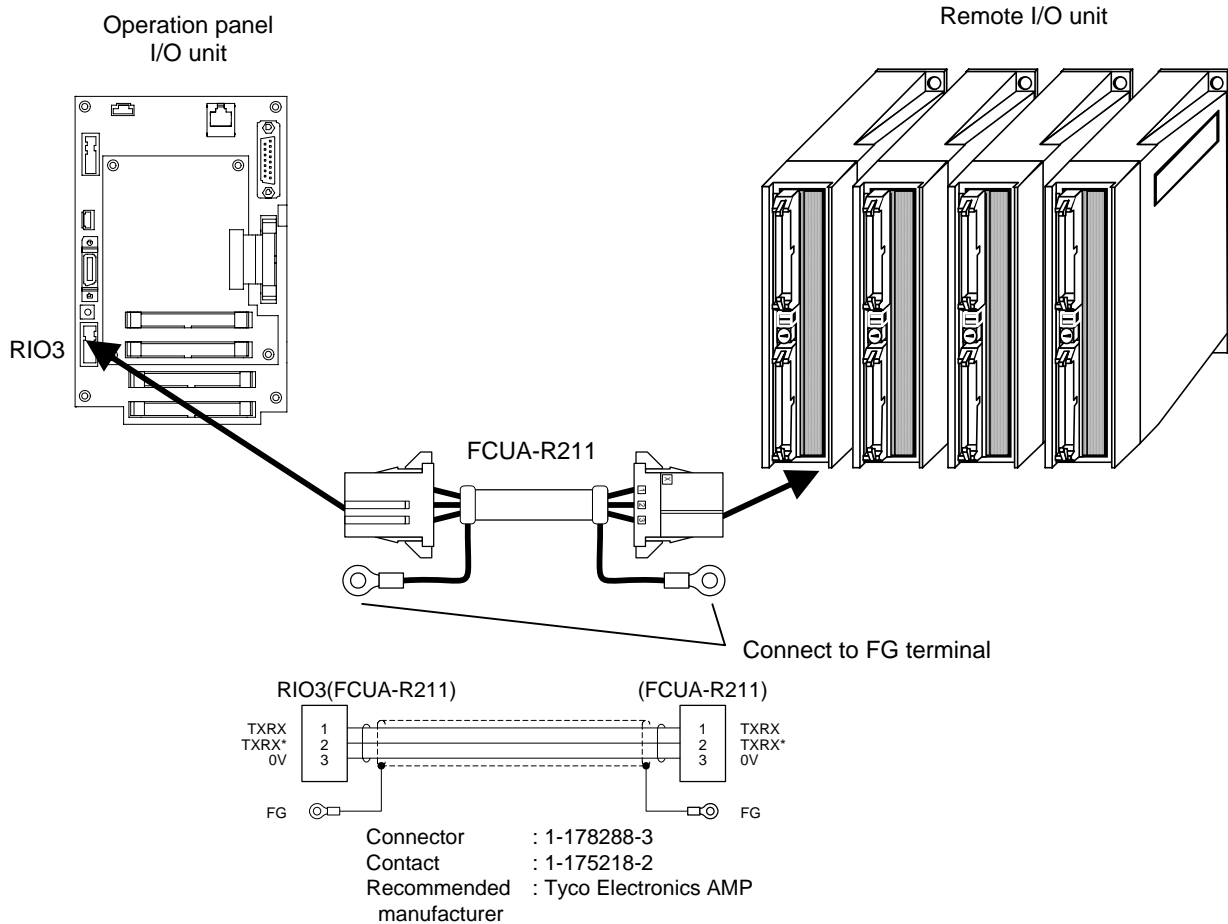

Refer to the following chart for the maximum number of connecting channels and I/O points.

Operation panel I/O unit type	Max. No. of channels (RIO3 connection)	Max. No. of I/O points (RIO3 connection)
FCU7-DX670	5 channels	160 points/160 points
FCU7-DX671	5 channels	160 points/160 points
FCU7-DX770	4 channels	128 points/128 points
FCU7-DX771	4 channels	128 points/128 points

(Note) Refer to the section "8.2 Connecting with Remote I/O Unit" for the number of occupied channels and I/O points of the remote I/O unit.

**<Related items>**

Cable drawing: "Appendix 2 (FCUA-R211 cable)"

Connector pin assignment: "Appendix 3 (R103 connector)"

**7.8. Connecting with Scan I/O Card and Card-sized I/O Card**

Refer to the section "8.3 Connecting with Scan I/O Card" and "8.4 Connecting with Card-sized I/O Card" for the connection of scan I/O card and card-sized I/O card to the operation panel I/O unit.

#### 7.9 Connecting with Machine Operation Panel

Connect machine operation panel to the connector CG31/CG32/CG33/CG34.

**<Related items>**

Cable drawing: "Appendix 2 (R300 cable, R301 cable)"

Connector pin assignment: "Appendix 3 (CG31/CG32/CG33/CG34)"

##### 7.9.1 Wiring the Input Side DI Connector (CG31/CG33)

The DI connector on the input side of the operation panel I/O unit is wired in the same manner as the M60/M600 Series base I/O unit (FCU6-DX Series) and remote I/O unit (FCUA-DX Series).

Refer to the section "7.9.3 Outline of Digital Signal Input Circuit".

##### 7.9.2 Wiring the Output Side DO Connector (CG32/CG34)

An insulation type DO output is used with the operation panel I/O unit. (Effective in improving the resistance against noise from external sources)

So, the DO output power is supplied from an external source, and the wiring method on the machine side differs from that of M60/M600 Series I/O unit (FCU6-DX Series, FCUA-DX Series).

Refer to the section "7.9.4 Outline of Digital Signal Output Circuit".

The wiring also differs for the sink type (FCU7-DX670/DX770) and source type (FCU7-DX671/DX771) DO output. Refer to the section "7.9.5 Wiring for Sink Type Output" and "7.9.6 Wiring for Source Type Output" for details on the wiring methods.

7.9.3 Outline of Digital Signal Input Circuit

Sink type and source type share the digital signal input circuit.  
Connect according to each respective diagram below.

Input circuit

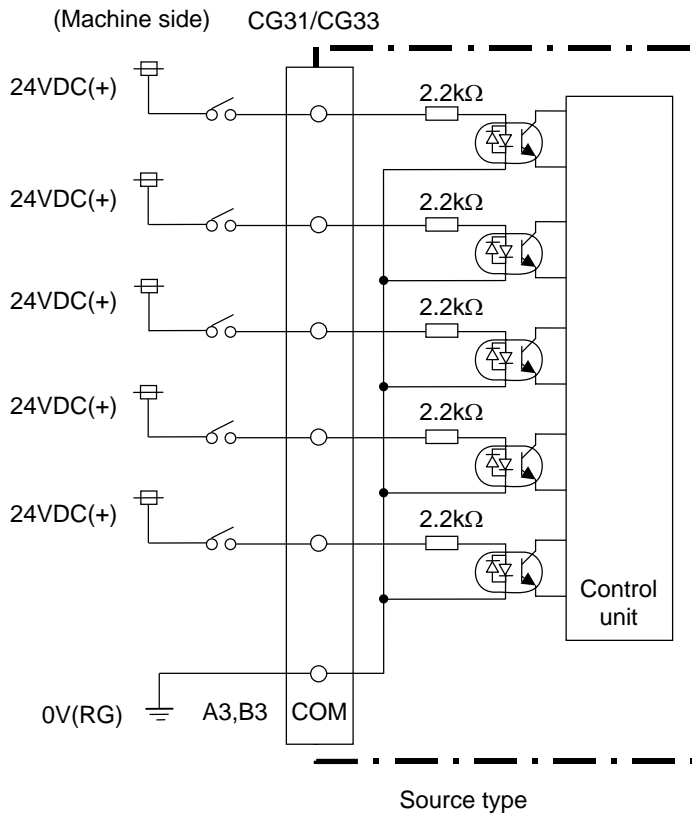
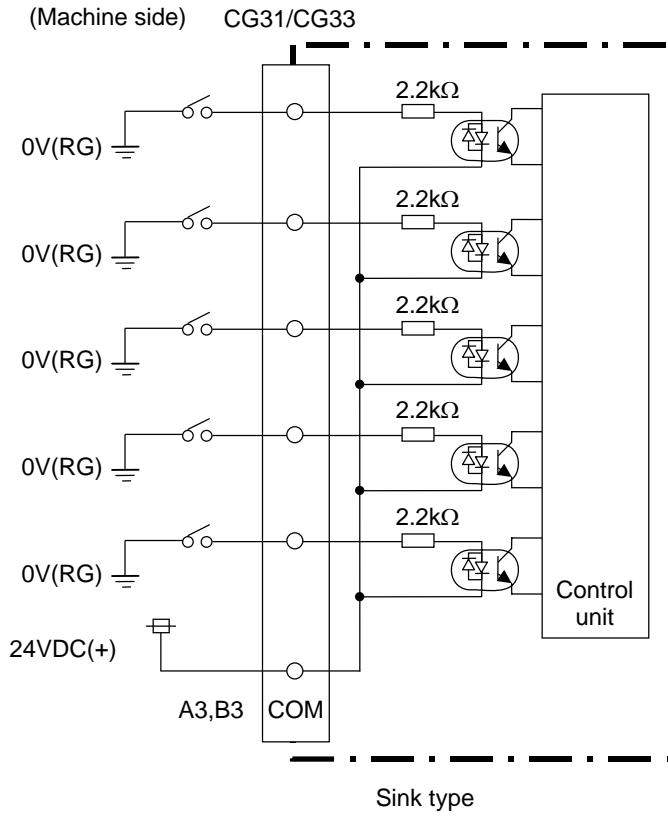

#### Input conditions

The input signals must be used within the following condition ranges.

		Sink type	Source type
1	Input voltage at external contact ON	6V or less	18V or more, 25.2V or less
2	Input current at external contact ON	9mA or more	
3	Input voltage at external contact OFF	20V or more, 25.2V or less	4V or less
4	Input current at external contact OFF	2mA or less	
5	Tolerable chattering time	3ms or less (Refer to T1 below)	
6	Input signal holding time	40ms or more (Refer to T2 below)	
7	Input circuit operation delay time	$3\text{ms} \leq T3 \leq T4 \leq 16\text{ms}$	
8	Machine side contact capacity	30V or more, 16mA or more	

**(Note)** Input signal holding time: 40ms or more as a guideline. The input signal can only be confirmed if held longer than the ladder process cycle time.

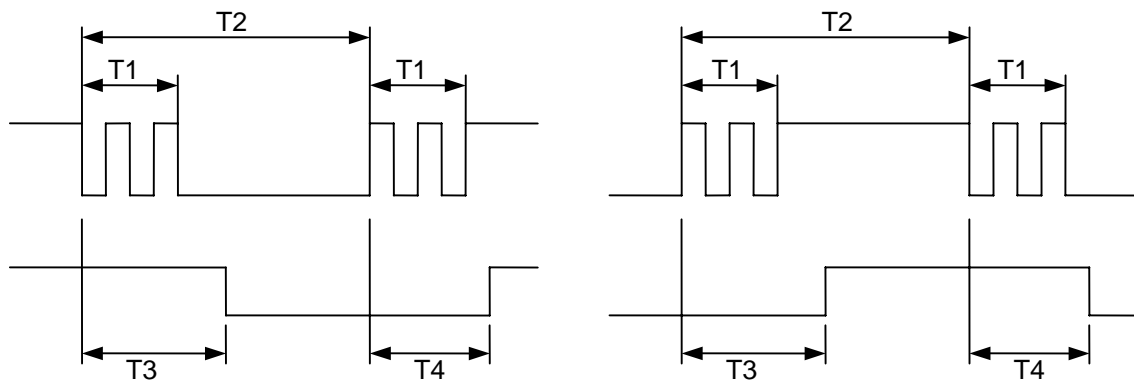

#### 7.9.4 Outline of Digital Signal Output Circuit

The digital signal output circuit uses a sink type (DX67□) or source type (DX77□). Use within the specification ranges shown below.

##### Output circuit

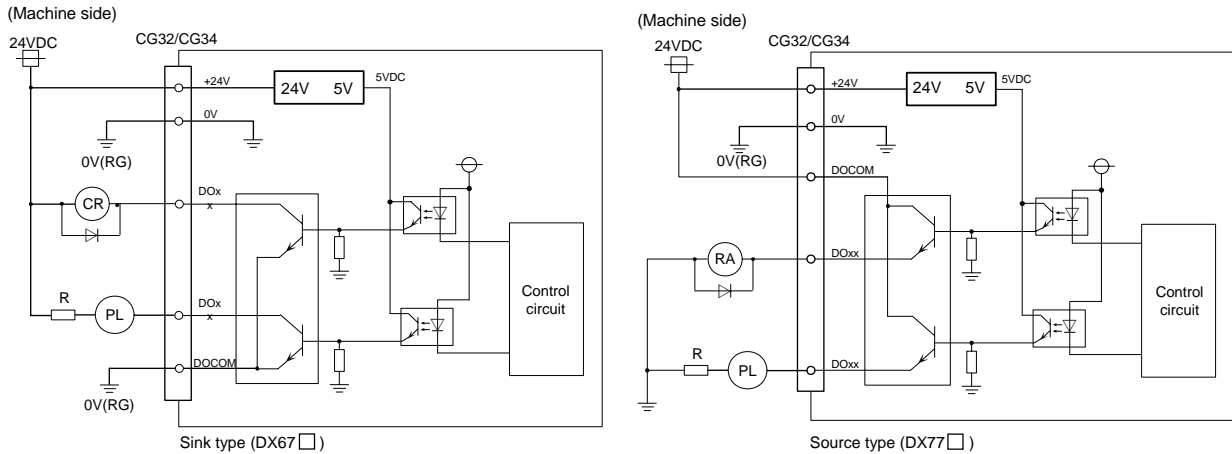

##### Output conditions

Insulation method	Insulation
Rated load voltage	24VDC
Max. output current	60mA/point
Output delay time	40μs

**(Note 1)** When using an inductive load such as a relay, always connect a diode (voltage resistance 100V or more, 100mA or more) in parallel to the load.

**(Note 2)** When using a capacitive load such as a lamp, always connect a protective resistor ( $R=150\Omega$ ) serially to the load to suppress rush currents. (Make sure that the current is less than the above tolerable current including the momentary current.)

#### **CAUTION**

- ❗ When using an inductive load such as a relay, always connect a diode in parallel to the load.
- ❗ When using a capacitive load such as a lamp, always connect a protective resistor serially to the load to suppress rush currents.

## 7. Connections of Operation Panel I/O Unit

### 7.9 Connecting with Machine Operation Panel

#### 7.9.5 Wiring for Sink Type Output (FCU7-DX670/DX770)

Operation panel I/O unit  
FCU7-DX670/DX770  
(Card name: HN391/HN396)

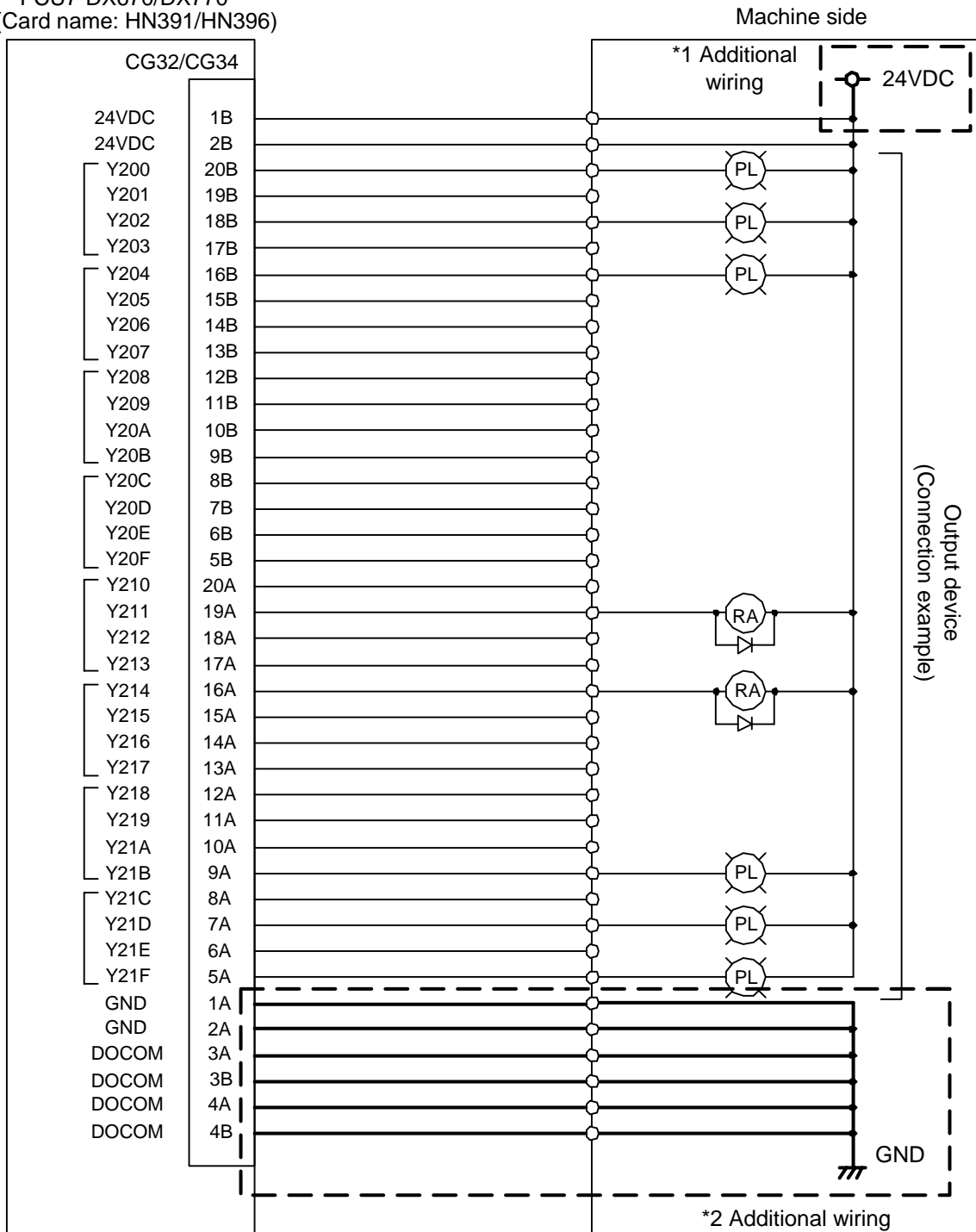

**(Note 1)** Connect +24V to the flat connector 1B, 2B (24VDC). (\*1)

**(Note 2)** Connect 0V (GND) to the flat connector 3A, 3B, 4A, 4B (DOCOM). (\*2)

**(Note 3)** Connect 0V (GND) to the flat connector 1A, 2A (GND). (\*2)

**(Note 4)** When large current flows due to small amount of connected load, fuse may be blown out or 24V power supply voltage may drop. In order to secure the appropriate current value, watch the connected load.





## 8. Connections of I/O Interface

I/O interface is connected to RIO1/RIO2 of the control unit and RIO3 of the operation panel I/O unit.

### 8.1 Types of I/O Interface

There are four types of I/O interfaces as shown below.

	Type	Explanation	Connection	Detailed configuration
1	Remote I/O	Connecting with analog input, analog output and manual pulse generator is possible besides DI/DO.	Refer to 8.2	Refer to 2.3.5
2	Scan I/O	DI/DO input/output (32/32) is possible besides scan type.	Refer to 8.3	Refer to 2.3.6
3	Card-sized I/O	55mm x 93mm in size. Connector PCB must be manufactured by the machine tool builder when using card size I/O card.	Refer to 8.4	Refer to 2.3.7
4	Expansion I/O	DI/DO input/output (64/48) is possible.	Refer to 8.5	Refer to 2.3.8

## 8.2 Connecting with Remote I/O Unit

This chapter describes the connection of the remote I/O unit and machine control signals.

### 8.2.1 Outline of Remote I/O Unit

The following eight types of signals can be input/output from the remote I/O unit (FCUA-DX ) according to the type and No. of contacts. Use serial link connections (MC link B) to connect the unit with the control unit or the operation panel I/O unit.

When the remote I/O unit is connected with serial links, multiple units can be used as long as the total No. of occupied stations (channels) is within 8 channels.

Unit type	Machine control signals that can be handled	No. of occupied serial link stations
FCUA-DX100	Digital input signal (DI) : 32 points (photo coupler insulation) sink/source type Digital output signal (DO) : 32 points (non-insulation) sink type	1
FCUA-DX101	Digital input signal (DI) : 32 points (photo coupler insulation) sink/source type Digital output signal (DO) : 32 points (non-insulation) source type	1
FCUA-DX110	Digital input signal (DI) : 64 points (photo coupler insulation) sink/source type Digital output signal (DO) : 48 points (non-insulation) sink type	2
FCUA-DX111	Digital input signal (DI) : 64 points (photo coupler insulation) sink/source type Digital output signal (DO) : 48 points (non-insulation) source type	2
FCUA-DX120	Digital input signal (DI) : 64 points (photo coupler insulation) sink/source type Digital output signal (DO) : 48 points (non-insulation) sink type Analog output (AO) : 1 point	2
FCUA-DX121	Digital input signal (DI) : 64 points (photo coupler insulation) sink/source type Digital output signal (DO) : 48 points (non-insulation) source type Analog output (AO) : 1 point	2
FCUA-DX140	Digital input signal (DI) : 32 points (photo coupler insulation) sink/source type Digital output signal (DO) : 32 points (non-insulation) sink type Analog input (AI) : 4 points Analog output (AO) : 1 point	2
FCUA-DX141	Digital input signal (DI) : 32 points (photo coupler insulation) sink/source type Digital output signal (DO) : 32 points (non-insulation) source type Analog input (AI) : 4 points Analog output (AO) : 1 point	2

8.2.2 Names of Each Remote I/O Unit Section

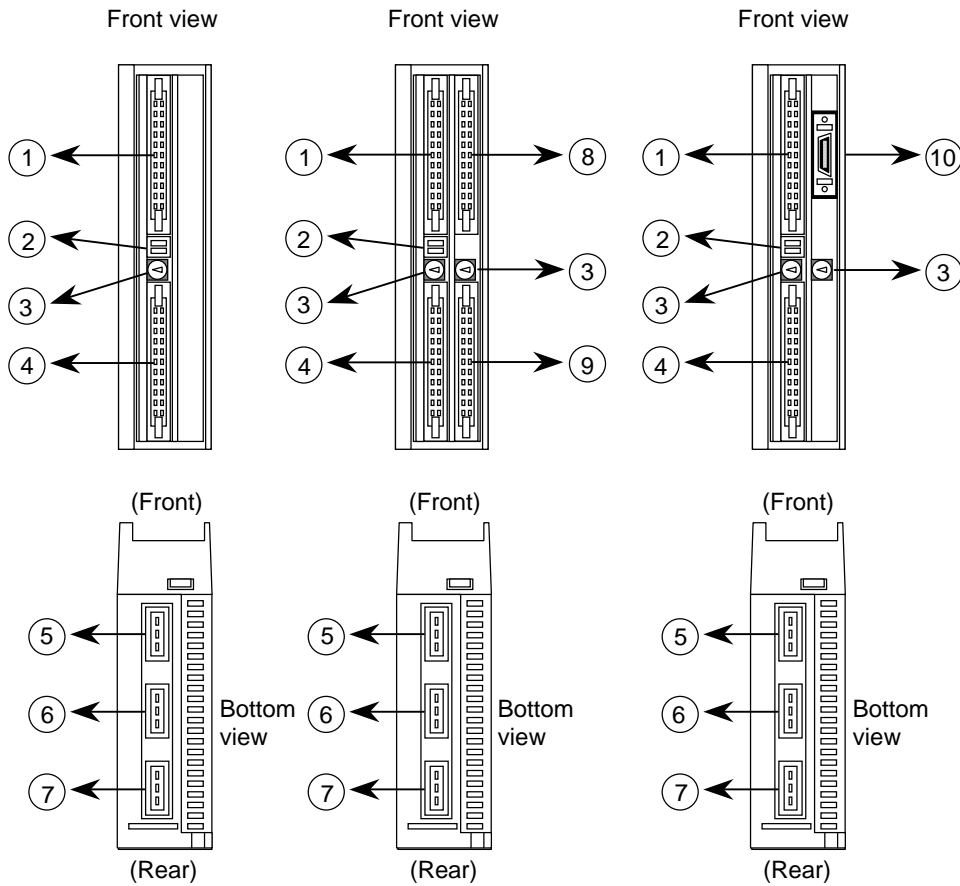

- ① DI-L (machine input signal connector)
- ② DS (transfer speed changeover switch)
- ③ CS (station No. changeover switch)
- ④ DO-L (machine output signal connector)
- ⑤ RIO1 (serial connection connector #1)
- ⑥ RIO2 (serial connection connector #2)
- ⑦ DCIN (24VDC (+) power input connector)
- ⑧ DI-R (machine input signal connector)
- ⑨ DO-R (machine output signal connector)
- ⑩ AIO (analog signal input/output connector)

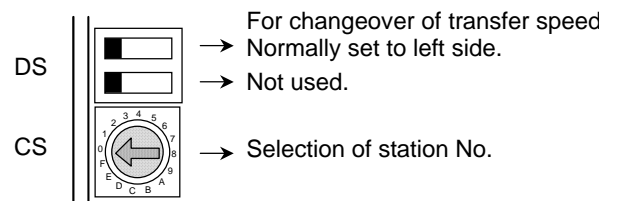

Enlarged view of DS and CS

8.2.3 Setting of Station No. When Using Multiple Remote I/O Units

When the remote I/O unit is connected with serial links (MC link B), multiple units can be used as long as the total No. of occupied stations is within 8 stations. Refer to the section "7.7 Connecting with Remote I/O Unit" for details on the remote I/O unit connected to RIO3 of the operation panel I/O unit.

Unit name	No. of occupied serial link stations
FCUA-DX10 □	1
FCUA-DX11 □	2
FCUA-DX12 □	2
FCUA-DX14 □	2

When using multiple remote I/O units, a characteristic station No. must be set for each unit. The FCUA-DX10 □ unit has one station No. setting switch, and FCUA-DX11 □, DX12 □ and DX14 □ unit have two switches. Each of these switches must be set to a characteristic station No. within a range of 0 to 7.

<Setting example 1>

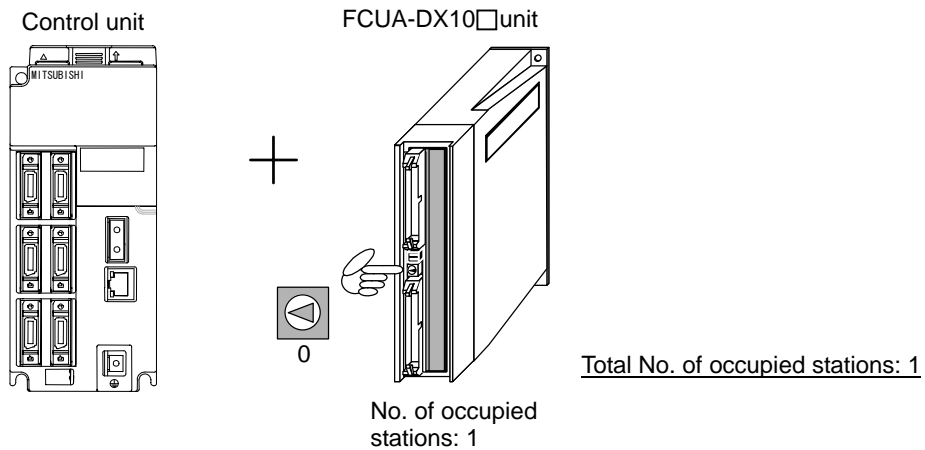

<Setting example 2>

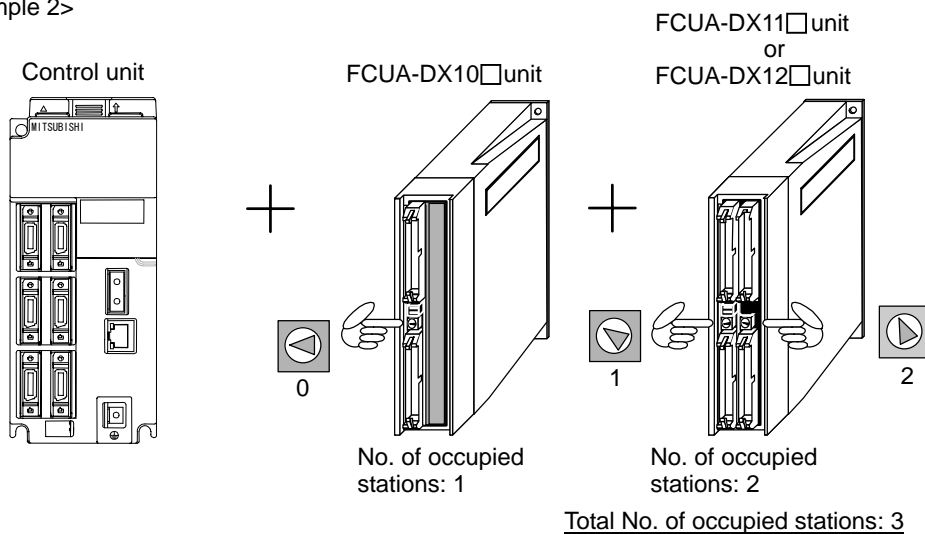

<Setting example 3>

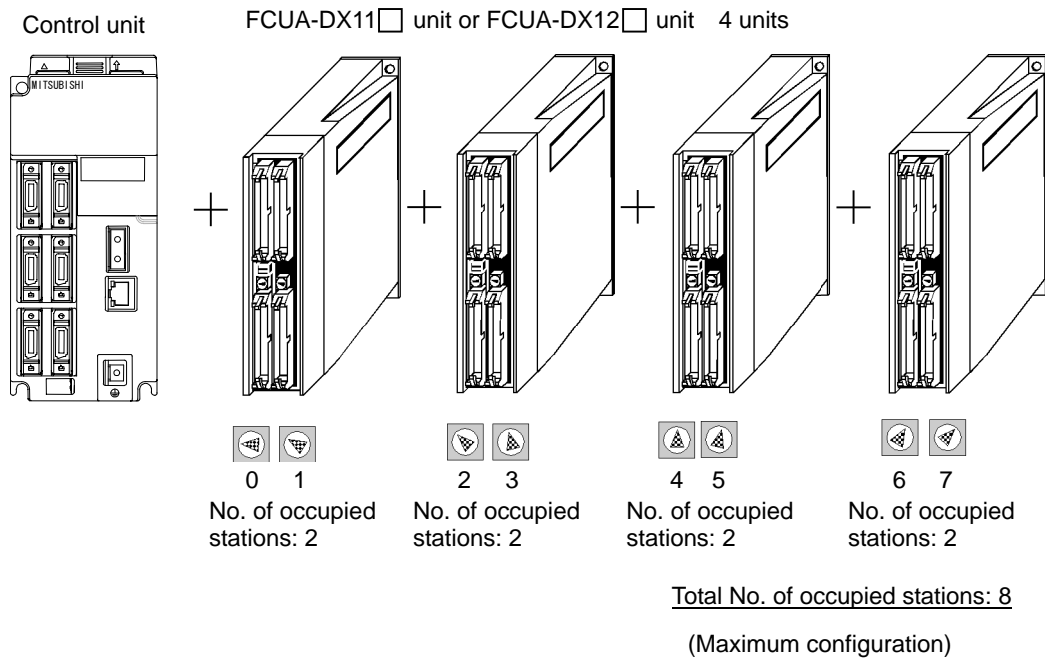

**(Note)** The assignment of each unit's input/output signal address will change with the setting of the channel No. Refer to "PLC Interface Manual" for details.

8.2.4 Outline of Digital Signal Input Circuit

Sink type and source type share the digital signal input circuit.  
Connect according to each respective diagram below.

Input circuit

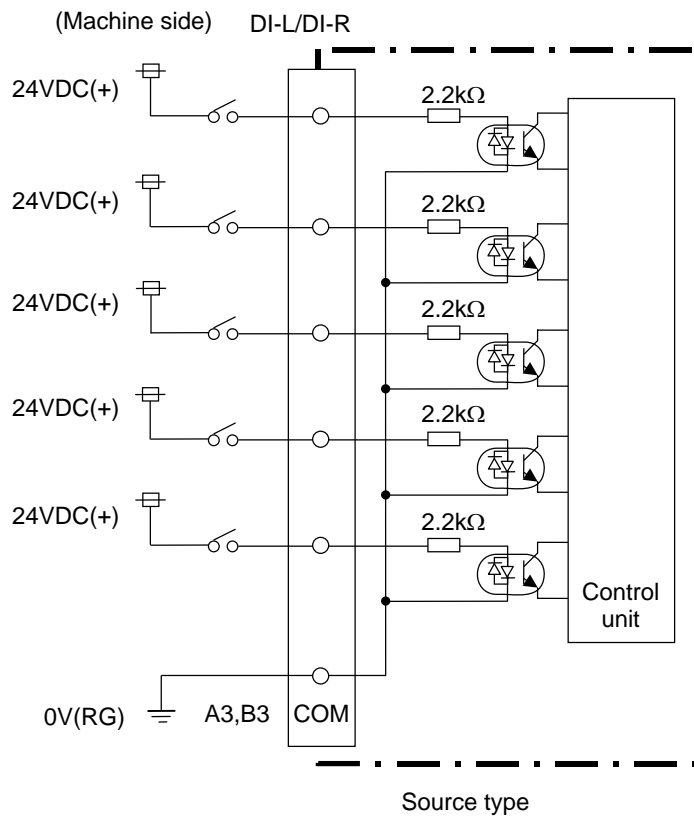
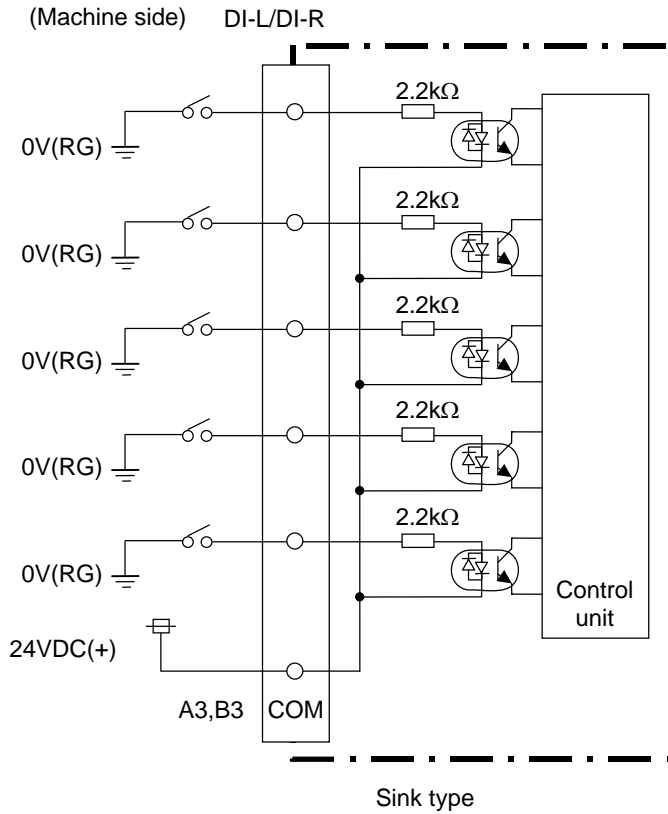

**Input conditions**

The input signals must be used within the following condition ranges.

		<b>Sink type</b>	<b>Source type</b>
1	Input voltage at external contact ON	6V or less	18V or more, 25.2V or less
2	Input current at external contact ON	9mA or more	
3	Input voltage at external contact OFF	20V or more, 25.2V or less	4V or less
4	Input current at external contact OFF	2mA or less	
5	Tolerable chattering time	3ms or less (Refer to T1 below)	
6	Input signal holding time	40ms or more (Refer to T2 below)	
7	Input circuit operation delay time	$3\text{ms} \leq T3 \approx T4 \leq 16\text{ms}$	
8	Machine side contact capacity	30V or more, 16mA or more	

**(Note)** Input signal holding time: 40ms or more as a guideline. The input signal can only be confirmed if held longer than the ladder process cycle time.

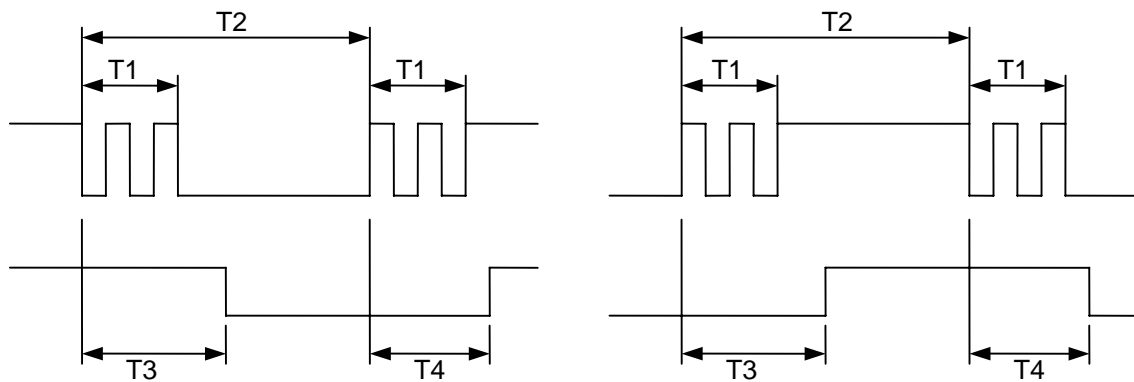

## 8.2.5 Outline of Digital Signal Output Circuit

The digital signal output circuit uses a sink type (DX1□0) or source type (DX1□1). Use within the specification ranges shown below.

## Output circuit

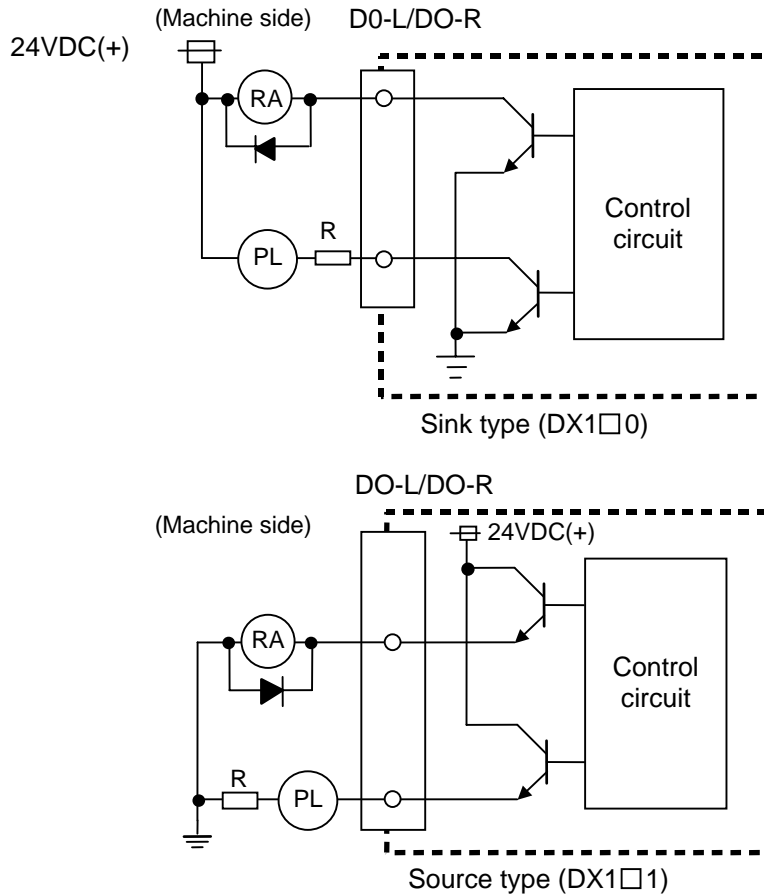

## Output conditions

Insulation method	Non-insulation
Rated load voltage	24VDC
Max. output current	60mA/point
Output delay time	40 $\mu$ s

**(Note 1)** When using an inductive load such as a relay, always connect a diode (voltage resistance 100V or more, 100mA or more) in parallel to the load.

**(Note 2)** When using a capacitive load such as a lamp, always connect a protective resistor ( $R=150\Omega$ ) serially to the load to suppress rush currents. (Make sure that the current is less than the above tolerable current including the momentary current.)

**⚠ CAUTION**

- ❗ When using an inductive load such as a relay, always connect a diode in parallel to the load.
- ❗ When using a capacitive load such as a ramp, always connect a protective resistor serially to the load to suppress rush currents.



## 8.2.6 Outline of Analog Signal Output Circuit

The analog signal output circuit can be used only for the FCUA-DX120/DX121/DX140/DX141.

## Output circuit

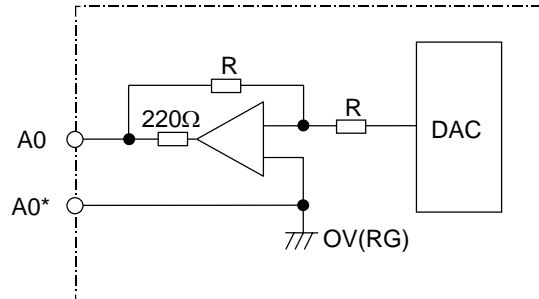

## Output conditions

Output voltage	0V to $\pm 10\text{V}$ ( $\pm 5\%$ )
Resolution	12bit ( $\pm 10\text{V} \times n/4096$ ) <b>(Note)</b>
Load conditions	10k $\Omega$ load resistance
Output impedance	220 $\Omega$

**(Note)**  $n = (2^0 \text{ to } 2^{11})$

## 8.2.7 Outline of Analog Signal Input Circuit

The analog signal input circuit can be used only for the FCUA-DX140/DX141.

## Input circuit

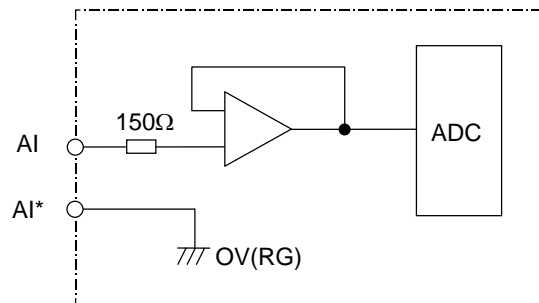

## Input conditions

Max. input rating	±15V
Resolution	10V/2000 (5mV)
Precision	Within ±25mV
AD input sampling time	14.2ms (AI0)/42.6ms (AI1 to 3)

8.2.8 Connection of FCUA-DX10□/14□ Unit and Machine Control Signal

Type of machine input/output signal and No. of points	Input	Output
	32 points	32 points

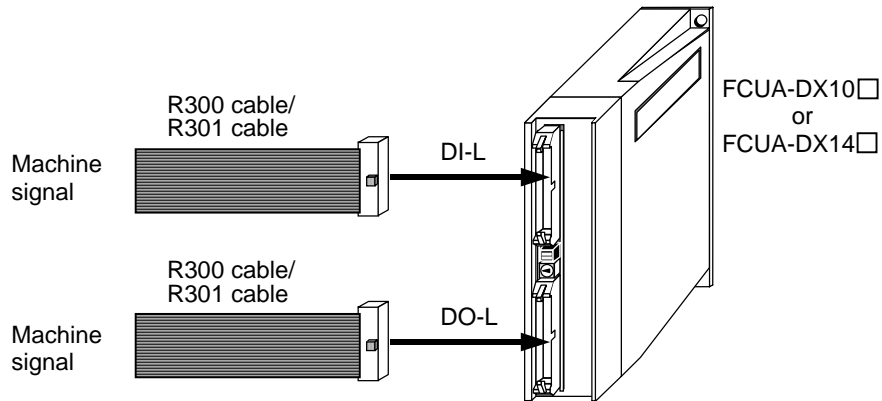

The remote I/O unit cable types include the R300 and R301 types. The R300 cable has one end cut off, and the R301 cable is used for connection to the IDEC terminal block BX1F-T40A (**Note 1**). The R300-3M and R301-3M cables are available. If a cable longer than 3m is required, use the CN300 and CS301 connector set. The one-end CN300 connector (optional, with one end) includes the DI-L (DI-R) and DO-L (DO-R) connectors. The CS301 connector set (optional with both ends) includes the DI-L and DO-L connectors, and two connectors for connection with the terminal block (IDEC).

**(Note 1)** IDEC I/O terminal BX1F-T40

<Outline of connection>

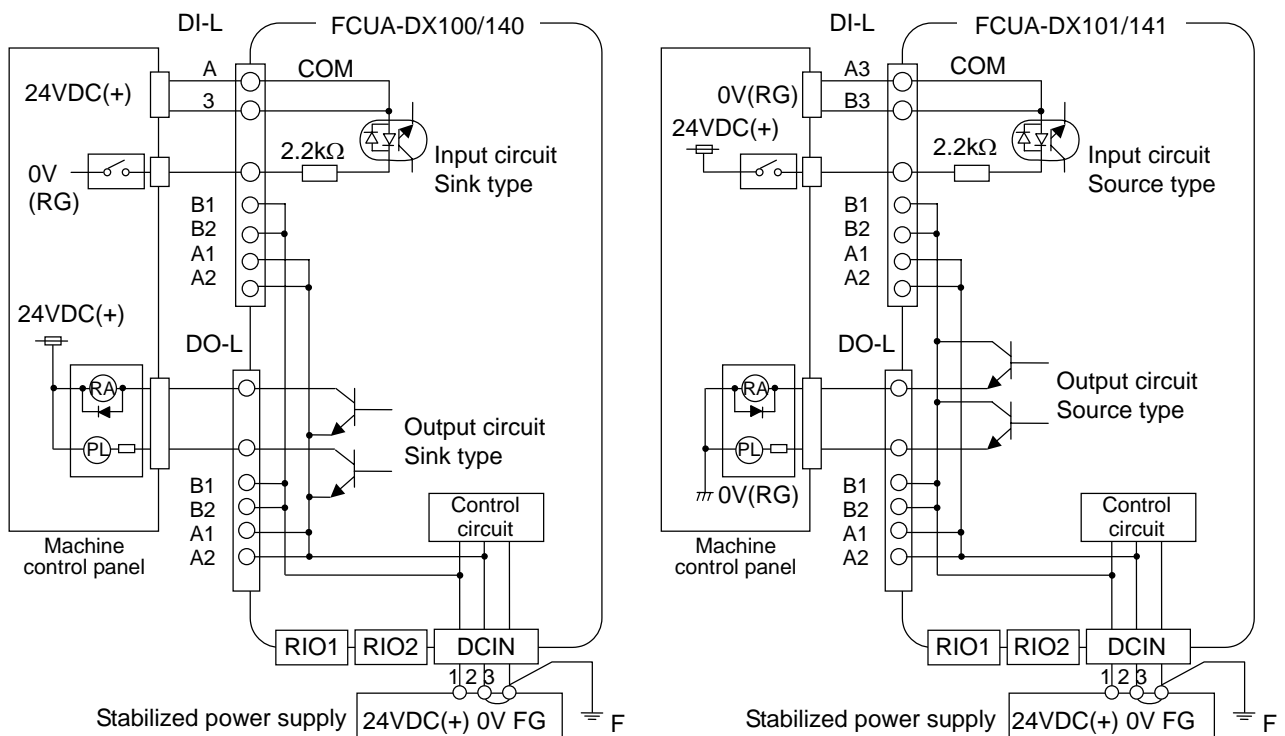

**CAUTION**

- ⚠ Incorrect connections could damage the device, so always connect the cable to the designated connector.
- ⊘ Do not connect or disconnect the connection cables between each unit while the power is ON.

<Signal assignment table>

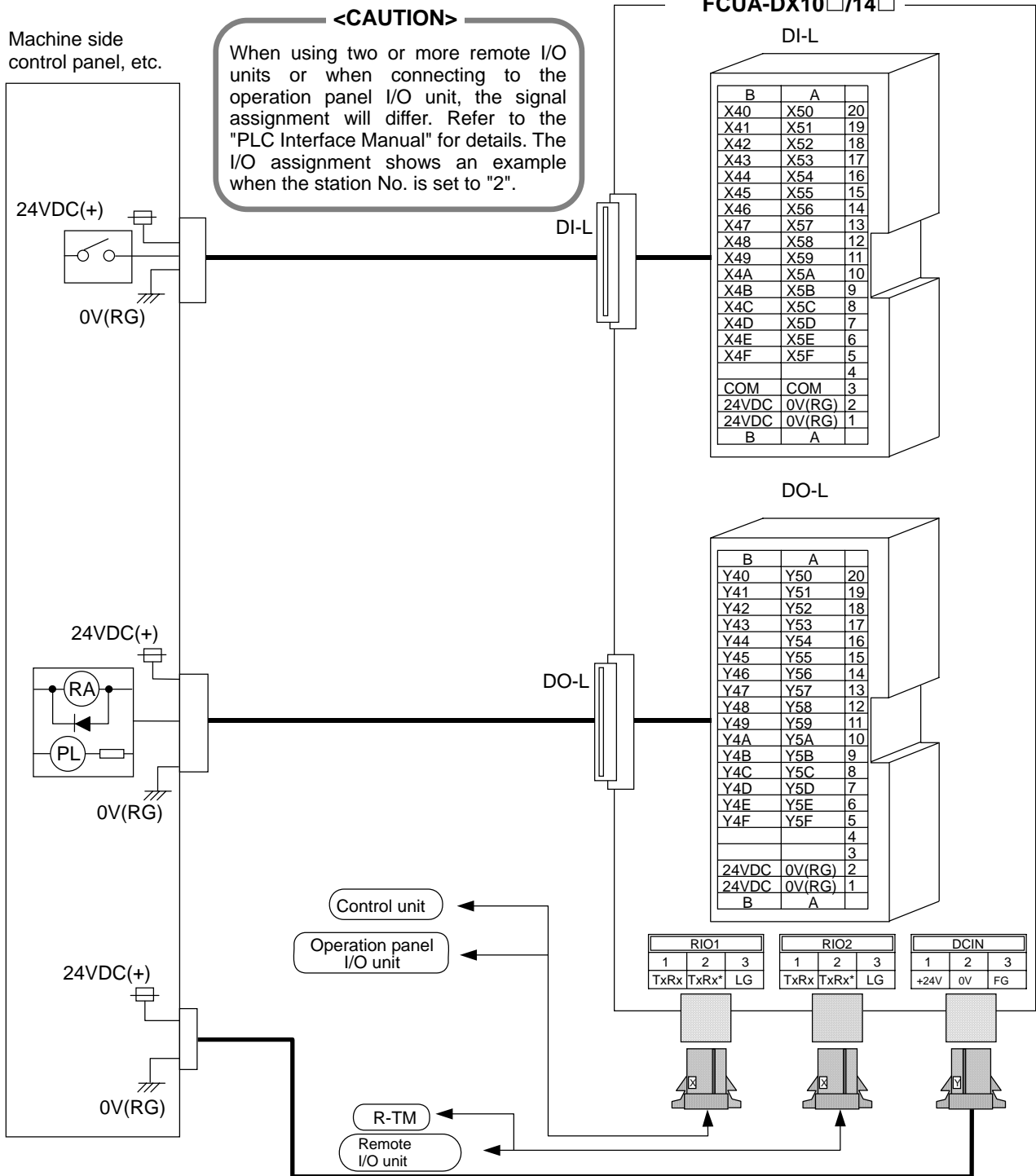

<Adaptive connector>

- DCIN (CN220)**  
 Connector: 2-178288-3  
 Contact: 1-175218-5  
 Manufacturer: Tyco Electronics AMP
- RIO1/RIO2 (CN211)**  
 Connector: 1-178288-3  
 Contact: 1-175218-2  
 Manufacturer: Tyco Electronics AMP
- DI-L/DO-L (CN300)**  
 Solderless type connector:  
 7940-6500SC  
 Manufacturer: 3M
- Terminator (R-TM)**  
 Connector: 1-178288-3  
 Contact: 1-175218-2  
 Manufacturer: Tyco Electronics AMP

(Note 1) ( ) is the MITSUBISHI original type name.  
 (Note 2) Refer to appendix 2 for the details on R-TM.

8.2.9 Connection of FCUA-DX14 □ Unit and Analog Input/Output Signal

For the analog input/output signal, the R031 cable is connected to "AIO". Up to four input points and one output point of the analog input/output signal can be connected. When manufacturing the R031 cable, use the CS000 connector set (optional, with both ends).

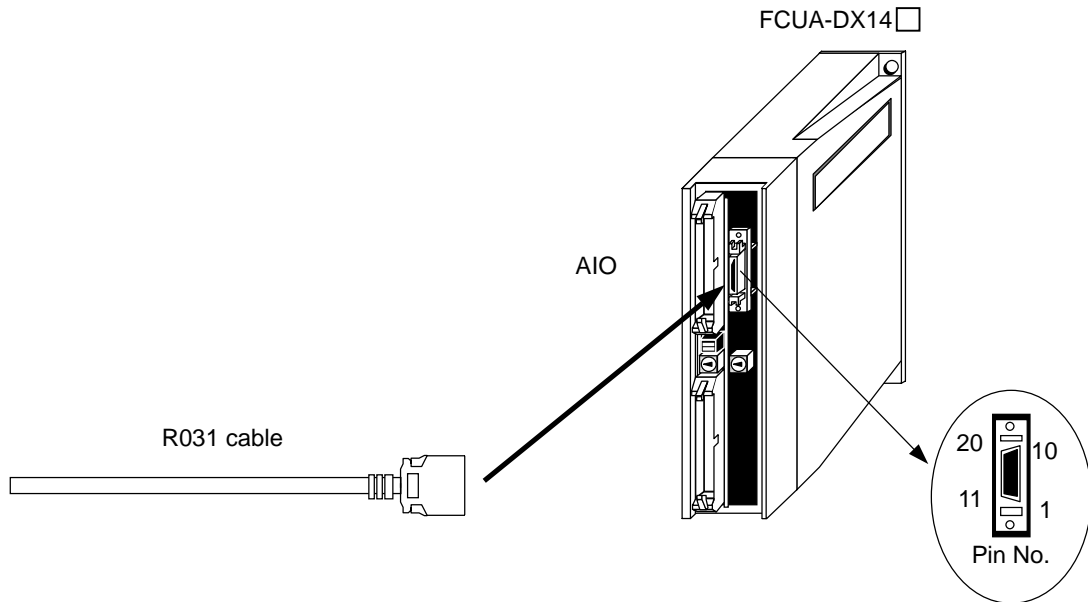

Input/output circuit

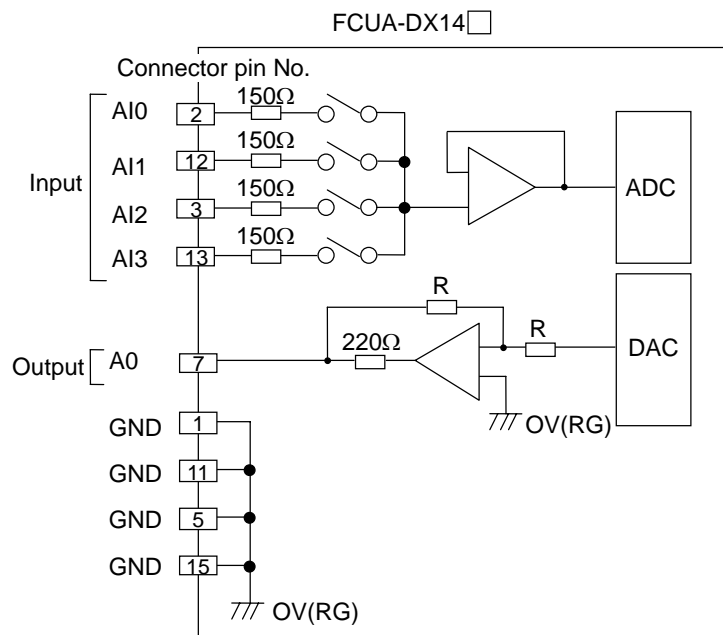

**CAUTION**

- ⚠ Incorrect connections could damage the device, so always connect the cable to the designated connector.
- ⊘ Do not connect or disconnect the connection cables between each unit while the power is ON.

8.2.10 Connection of FCUA-DX11□ Unit and Machine Control Signal

Type of machine input/output signal and No. of points	Input 64 points	Output 48 points
---	--------------------	---------------------

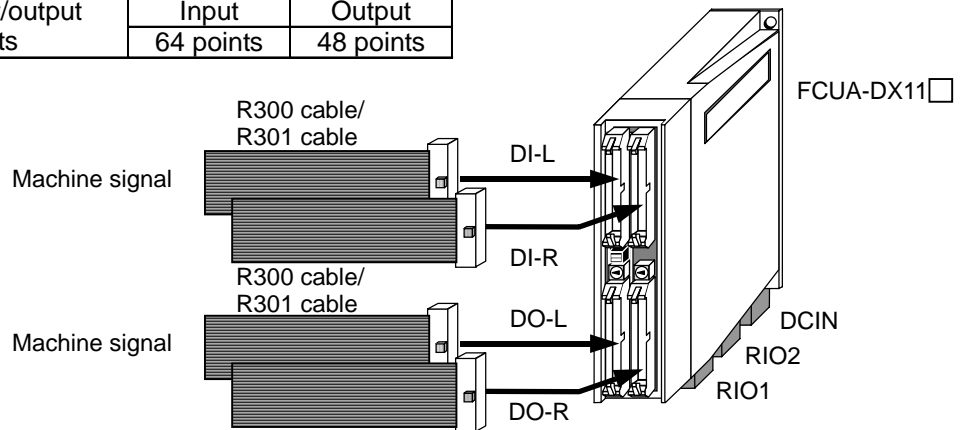

The remote I/O unit cable types include the R300 and R301 types. The R300 cable has one end cut off, and the R301 cable is used for connection to the IDEC terminal block BX1F-T40A (**Note 1**). The R300-3M and R301-3M cables are available. If a cable longer than 3m is required, use the CN300 and CS301 connector set. The one-end CN300 connector (optional, with one end) includes the DI-L (DI-R) and DO-L (DO-R) connectors. The CS301 connector set (optional with both ends) includes the DI-L and DO-L connectors, and two connectors for connection with the terminal block (IDEC).

**(Note 1)** IDEC I/O terminal BX1F-T40

<Outline of connection>

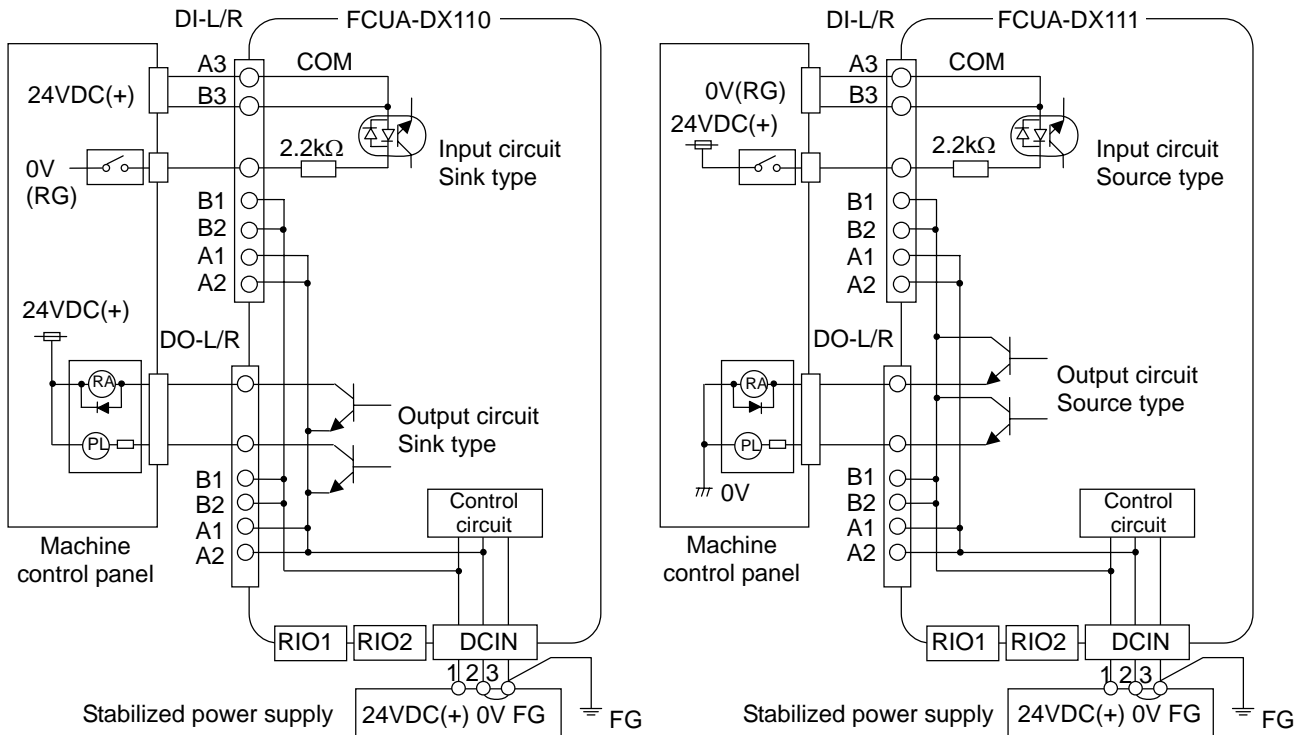

**CAUTION**

- Incorrect connections could damage the device, so always connect the cable to the designated connector.
- Do not connect or disconnect the connection cables between each unit while the power is ON.

<Signal assignment table>

<CAUTION>

When using two or more remote I/O units or when connecting to the operation panel I/O unit, the signal assignment will differ. Refer to the "PLC Interface Manual" for details. The I/O assignment shows an example when the station No. is set to "2".

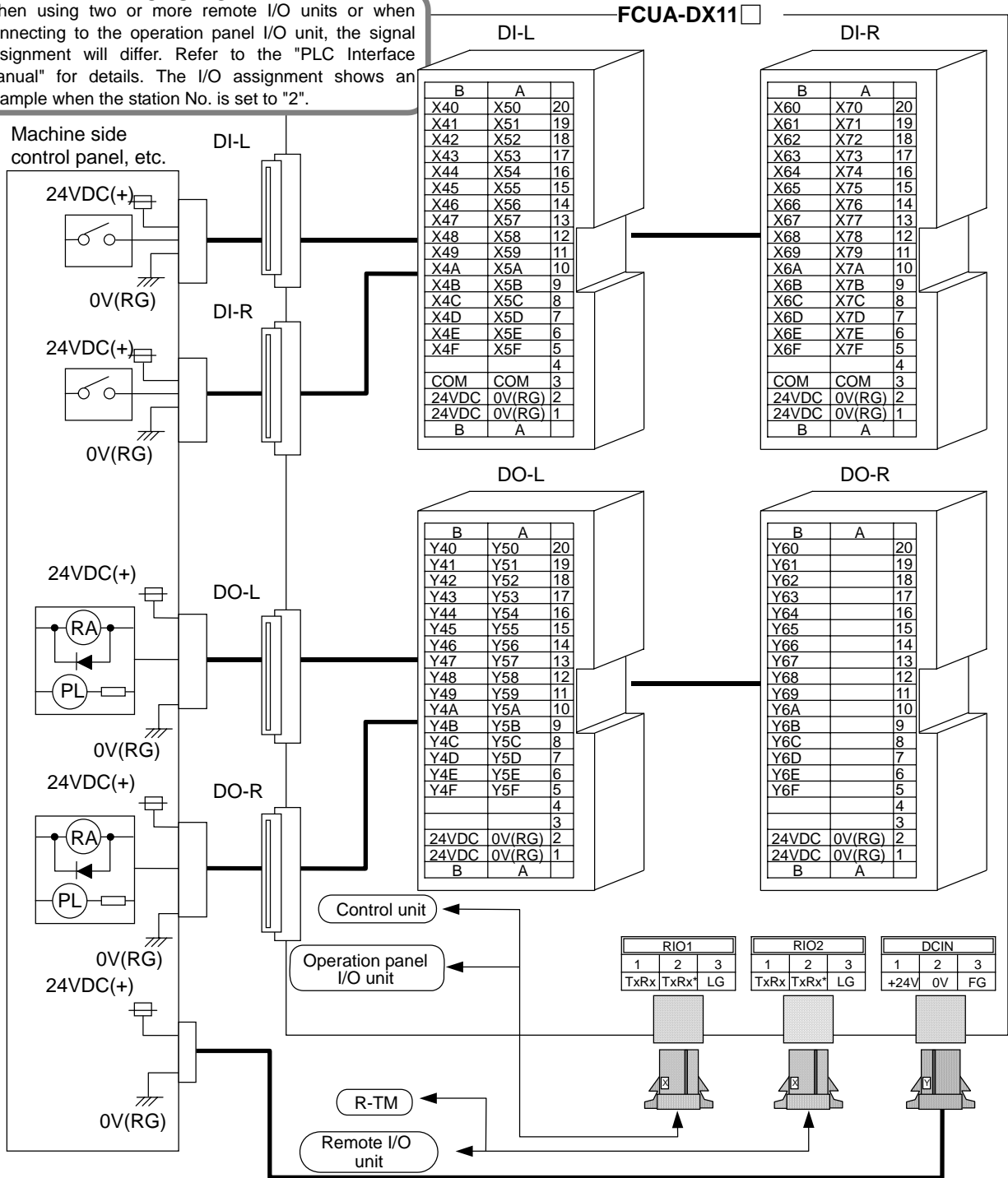

<Adaptive connector>

- DCIN (CN220)**  
 Connector: 2-178288-3  
 Contact: 1-175218-5  
 Manufacturer: Tyco Electronics AMP
- RIO1/RIO2 (CN211)**  
 Connector: 1-178288-3  
 Contact: 1-175218-2  
 Manufacturer: Tyco Electronics AMP
- DI-L/DO-L (CN300)  
DI-R/DO-R**  
 Solderless type  
 connector: 7940-6500SC  
 Manufacturer: 3M
- Terminator (R-TM)**  
 Connector: 1-178288-3  
 Contact: 1-175218-2  
 Manufacturer: Tyco Electronics AMP

(Note 1) ( ) is the MITSUBISHI original type name.  
 (Note 2) Refer to appendix 2 for the details on R-TM.

8.2.11 Connection of FCUA-DX12□ Unit and Machine Control Signal

Type of machine input/output signal and No. of points	Input	Output	Analog output
		64 points	48 points

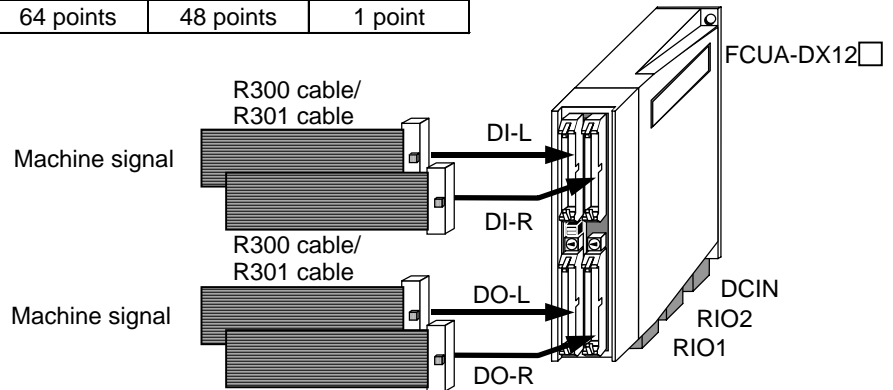

The remote I/O unit cable types include the R300 and R301 types. The R300 cable has one end cut off, and the R301 cable is used for connection to the IDEC Denki terminal block BX1F-T40A (**Note 1**). The R300-3M and R301-3M cables are available. If a cable longer than 3m is required, use the CN300 and CS301 connector set.

The one-end connector CN300 (optional, with one end) includes the DI-L (DI-R) and DO-L (DO-R) connectors. The CS301 connector set (optional, with both ends) includes the DI-L and DO-L connectors, and two connectors for connection with the terminal block (IDEC).

**(Note 1)** IDEC I/O terminal BX1F-T40

<Outline of connection>

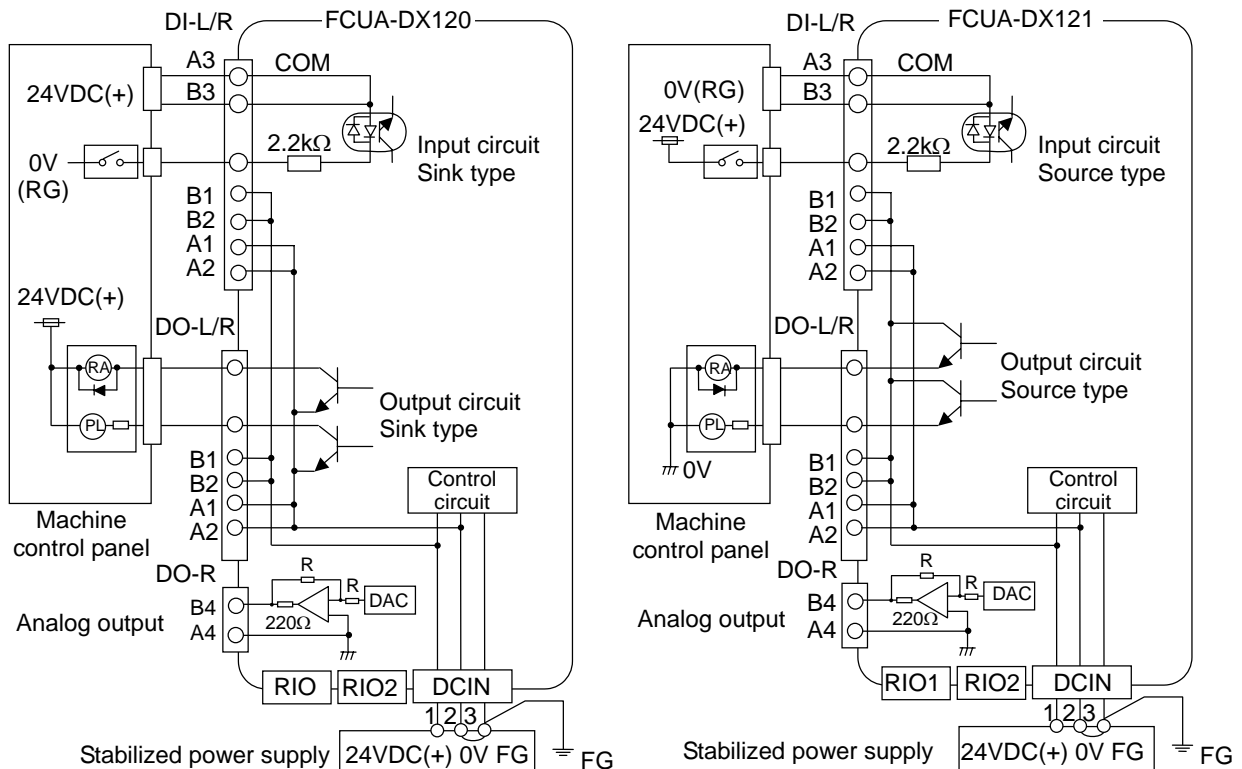

**CAUTION**

- Incorrect connections could damage the device, so always connect the cable to the designated connector.
- Do not connect or disconnect the connection cables between each unit while the power is ON.



<Signal assignment table>

<CAUTION>

When using two or more remote I/O units or when connecting to the operation panel I/O unit, the signal assignment will differ. Refer to the "PLC Interface Manual" for details. The I/O assignment shows an example when the station No. is set to "2".

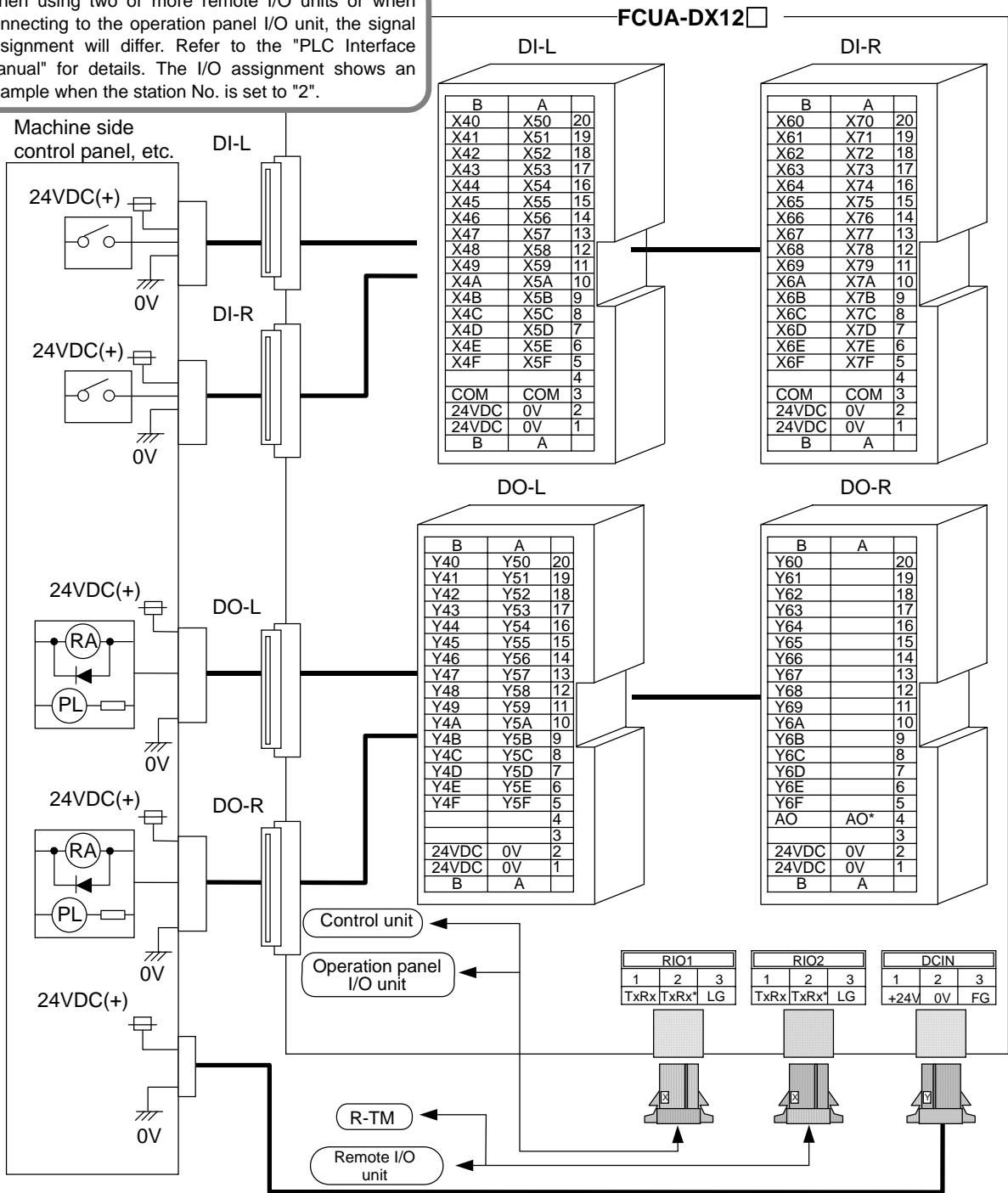

<Adaptive connector>

- DCIN (CN220)**  
 Connector: 2-178288-3  
 Contact: 1-175218-5  
 Manufacturer: Tyco Electronics AMP
- RIO1/RIO2 (CN211)**  
 Connector: 1-178288-3  
 Contact: 1-175218-2  
 Manufacturer: Tyco Electronics AMP
- DI-L/DO-L (CN300)  
DI-R/DO-R**  
 Solderless type  
 connector: 7940-6500SC  
 Manufacturer: 3M
- Terminator (R-TM)**  
 Connector: 1-178288-3  
 Contact: 1-175218-2  
 Manufacturer: Tyco Electronics AMP

(Note 1) ( ) is the MITSUBISHI original type name.  
 (Note 2) Refer to appendix 2 for the details on R-TM.

8.2.12 Cables

The remote I/O unit cable types include the R300 and R301 types. The R300 cable has one end cut off, and the R301 cable is used for connection to the IDEC terminal block BX1F-T40A (**Note 1**). Both the R300-3M and R301-3M are available.

If a cable longer than 3m is required, use the CN300 or CS301 connector set.

For the analog input/output cable, the R031 cable must be manufactured by the user.

**(Note 1)** IDEC I/O terminal BX1F-T40A

Machine control panel,  
electric cabinet, etc.

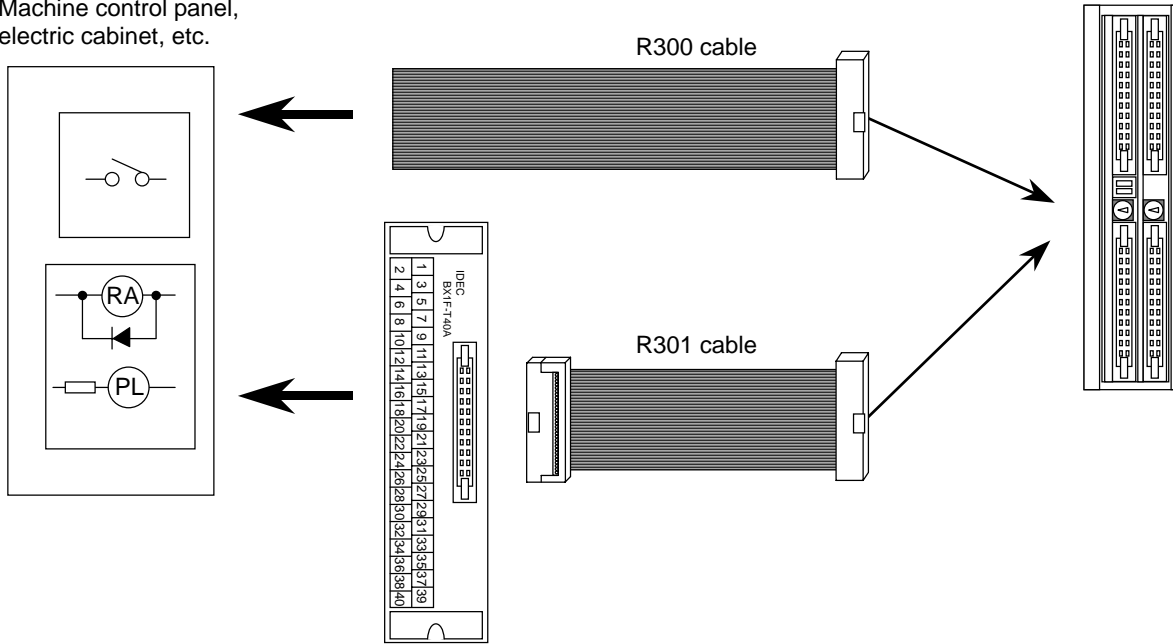

Connector pin correspondence table

Terminal block BX1F	FCUA-DX1□□	Terminal block BX1F	FCUA-DX1□□
1	A1	2	B1
3	A2	4	B2
5	A3	6	B3
7	A4	8	B4
9	A5	10	B5
11	A6	12	B6
13	A7	14	B7
15	A8	16	B8
17	A9	18	B9
19	A10	20	B10
21	A11	22	B11
23	A12	24	B12
25	A13	26	B13
27	A14	28	B14
29	A15	30	B15
31	A16	32	B16
33	A17	34	B17
35	A18	36	B18
37	A19	38	B19
39	A20	40	B20

## 8.3 Connecting with Scan I/O Card

## 8.3.1 Outline

The HR347/357 card is the machine operation board input/output card. It has a digital input/output and scan input/output, and is connected to the machine operation board and other devices.

		Item	HR347	HR357
Scan	Input	No. of points	64 points	
		Configuration	8 common × 8 data matrix	
		Rated voltage	5VDC	
		Max. current	80mA/point	
		Input cycle	1.46ms cycle, 11.68ms cycle	
		Input signal holding time	11.68ms or more (*1)	
	Output	No. of points	64 points	
		Configuration	4 common × 8 data + 4 common × 8 data matrix	
		Rated load voltage	5VDC	
		Max. output current	200mA/point	
Digital	Input	Output cycle	1.46ms cycle, 5.84ms cycle	
		No. of points	32 points	
		Type	Sink/source	
		Input voltage at external contact ON	6V or less	18V or more, 25.2V or less
		Input current at external contact ON	2mA or less	9mA or more
		Input voltage at external contact OFF	20V or more, 25.2V or less	4V or less
		Input current at external contact OFF	9mA or more	2mA or less
		Tolerable chattering time	2.2ms or less	
		Input signal holding time	40ms or more	
		Input circuit operation delay time	2.2ms ≤ T3 ≐ T4 ≤ 11ms	
	Machine side contact capacity	30V or more, 16mA or more		
	Output	No. of points	32 points	
		Rated load voltage	24VDC	
		Max. output current	60mA/point	
Type		Sink	Source	

(\*1) Input signal holding time: The guide is 11.68ms or more. The input signal will not be recognized unless it is held for the ladder processing cycle time or longer.

8.3.2 Hardware Interface

(1) Connector layout diagram

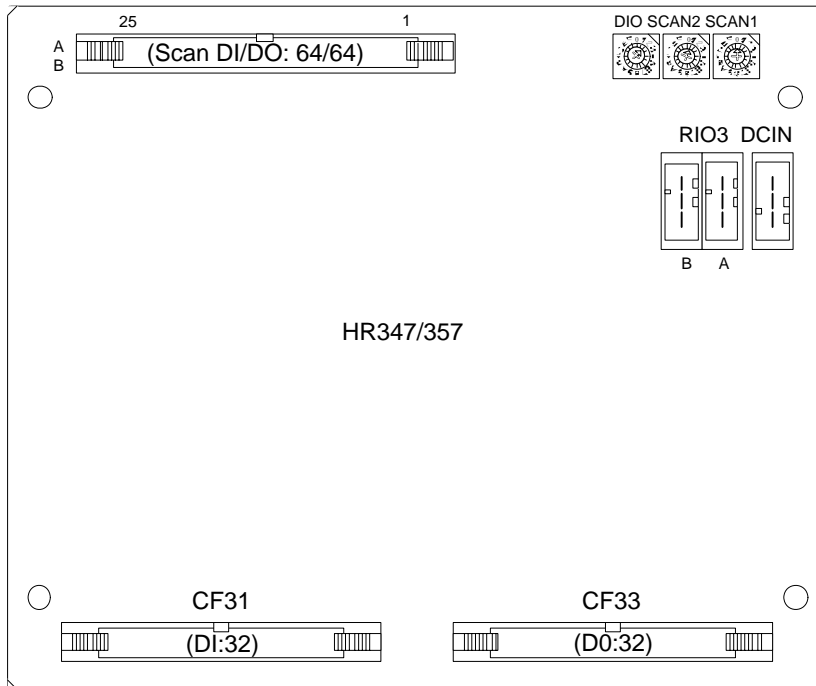

(2) Pin assignment

Remote I/O unit connection terminal  
RIO3A/B

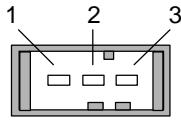

<Cable side connector type>  
Connector: 1-178288-3  
Contact: 1-175218-2  
Recommended manufacturer:  
Tyco Electronics AMP

1	I/O	TXRX3
2	I/O	TXRX3*
3		GND

Power input terminal (24VDC)  
DCIN

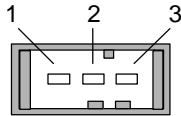

<Cable side connector type>  
Connector: 2-178288-3  
Contact: 1-175218-5  
Recommended manufacturer:  
Tyco Electronics AMP

1	I	24VDC
2		0V(RG)
3		FG

Machine input/output terminal

CF31

		B			A
20	I	X40	20	I	X50
19	I	X41	19	I	X51
18	I	X42	18	I	X52
17	I	X43	17	I	X53
16	I	X44	16	I	X54
15	I	X45	15	I	X55
14	I	X46	14	I	X56
13	I	X47	13	I	X57
12	I	X48	12	I	X58
11	I	X49	11	I	X59
10	I	X4A	10	I	X5A
9	I	X4B	9	I	X5B
8	I	X4C	8	I	X5C
7	I	X4D	7	I	X5D
6	I	X4E	6	I	X5E
5	I	X4F	5	I	X5F
4			4		
3	I	COM	3	I	COM
2	I	24VDC	2		0V(RG)
1	I	24VDC	1		0V(RG)

CF33

		B			A
20	O	Y40	20	O	Y50
19	O	Y41	19	O	Y51
18	O	Y42	18	O	Y52
17	O	Y43	17	O	Y53
16	O	Y44	16	O	Y54
15	O	Y45	15	O	Y55
14	O	Y46	14	O	Y56
13	O	Y47	13	O	Y57
12	O	Y48	12	O	Y58
11	O	Y49	11	O	Y59
10	O	Y4A	10	O	Y5A
9	O	Y4B	9	O	Y5B
8	O	Y4C	8	O	Y5C
7	O	Y4D	7	O	Y5D
6	O	Y4E	6	O	Y5E
5	O	Y4F	5	O	Y5F
4			4		
3			3		
2	I	24VDC	2		0V(RG)
1	I	24VDC	1		0V(RG)

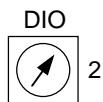

<Cable side connector type>  
Connector: 7940-6500SC  
Relief: 3448-7940  
Recommended manufacturer: 3M

\* This example shows SCAN1 set to "0", SCAN2 set to "1", and DIO set to "2".  
Refer to "PLC Interface Manual" for details.

Scan type input/output terminals  
CF35

		B			A
25		GND	25		GND
24	O	LC3B	24	O	LC3A
23	O	LC2B	23	O	LC2A
22	O	LC1B	22	O	LC1A
21	O	LC0B	21	O	LC0A
20	I	LD7B*	20	I	LD7A*
19	I	LD6B*	19	I	LD6A*
18	I	LD5B*	18	I	LD5A*
17	I	LD4B*	17	I	LD4A*
16	I	LD3B*	16	I	LD3A*
15	I	LD2B*	15	I	LD2A*
14	I	LD1B*	14	I	LD1A*
13	I	LD0B*	13	I	LD0A*
12		GND	12		
11			11		
10			10		
9	O	KYC7*	9	O	KYC6*
8	O	KYC5*	8	O	KYC4*
7	O	KYC3*	7	O	KYC2*
6	O	KYC1*	6	O	KYC0*
5	I	KYD7*	5	I	KYD6*
4	I	KYD5*	4	I	KYD4*
3	I	KYD3*	3	I	KYD2*
2	I	KYD1*	2	I	KYD0*
1			1		GND

**(Note)**

The GND pin is not normally used.  
Do not connect the GND pin to the frame ground.

**<Cable side connector type>**

Connector: 7950-6500SC  
Relief: 3448-7950  
Recommended manufacturer: 3M

LCx/A/B	Common signal for scan DO
LDx/A/B*	Data signal for scan DO
KYCx*	Common signal for scan DI
KYDx*	Data signal for scan DI

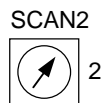
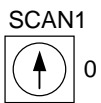

\* This example shows SCAN1 set to "0", SCAN2 set to "1" and DIO set to "2".  
Refer to "PLC Interface Manual" for details.

(3) Rotary switch

Set the address (station No.) assignment in DI/DO: 32/32 point units. Set using SCAN1, SCAN 2 and DIO rotary switches. The assignment address is changed with the rotary switch setting.

CF35

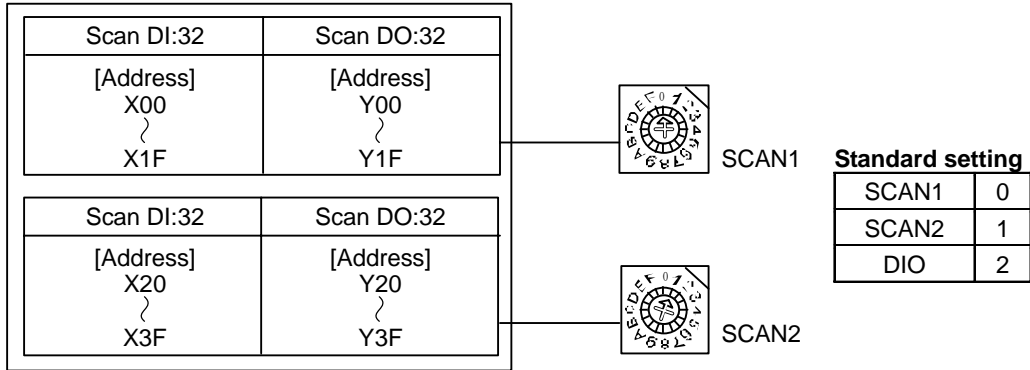

CF31

CF33

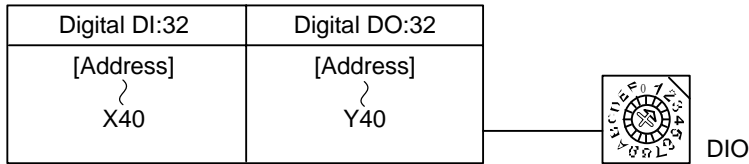

8.3.3 Connections

(1) External power supply (DCIN)

24VDC is required for the HR347/HR357 card operation. Prepare a stabilized power supply that satisfies the following specifications.

- Output : 24VDC  $\pm$  5%
- Ripple :  $\pm$  5% (P-P)
- Rated output current: 2.5A

\* The rated output current is the value when using 60mA  $\times$  32 points for the machine output. Prepare a power supply that satisfies the 24VDC output's total output current and control current (0.5A).

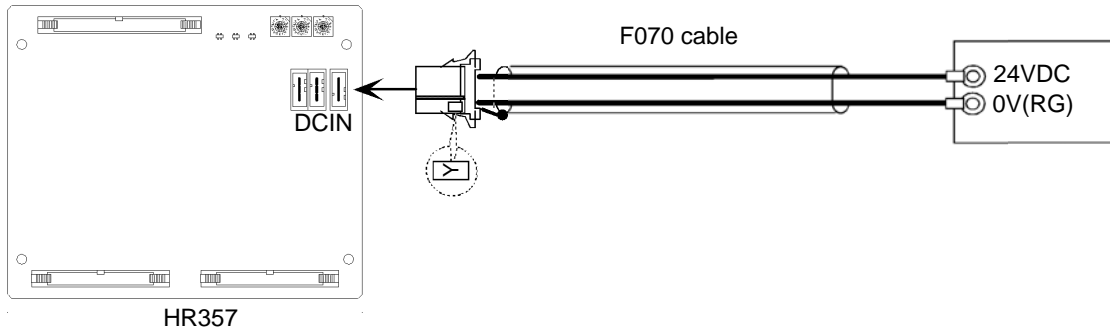

(2) Connecting the remote I/O communication cable (RIO3A/B)

(a) Connection of the RIO3A connector

Connect the RIO3A to the RIO1/RIO2 connector of the control unit or the RIO3 of the operation panel I/O unit.

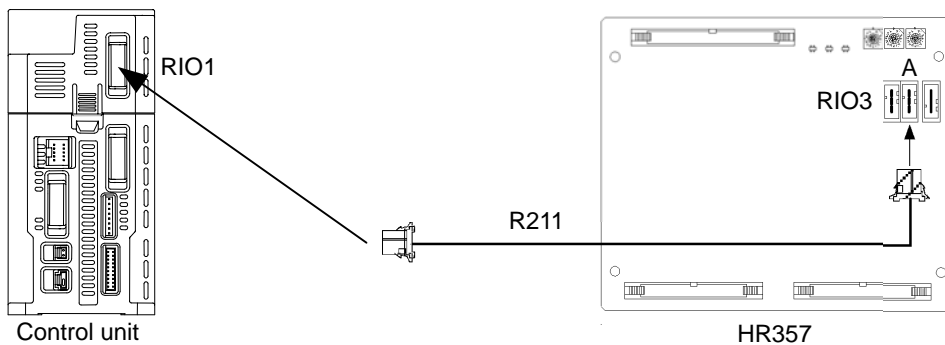

(b) Connection of the RIO3B connector

When the remote I/O unit is connected with a serial link, multiple units can be combined and used in a range of eight or less total occupied stations. (Refer to the section "8.2 Connecting with Remote I/O Unit" for details.)

HR357 occupies three stations, so the remote I/O units can be connected to the RIO3B in combinations of 5 stations or less. Connect a terminator to the RIO3B when it is not connected to any device.

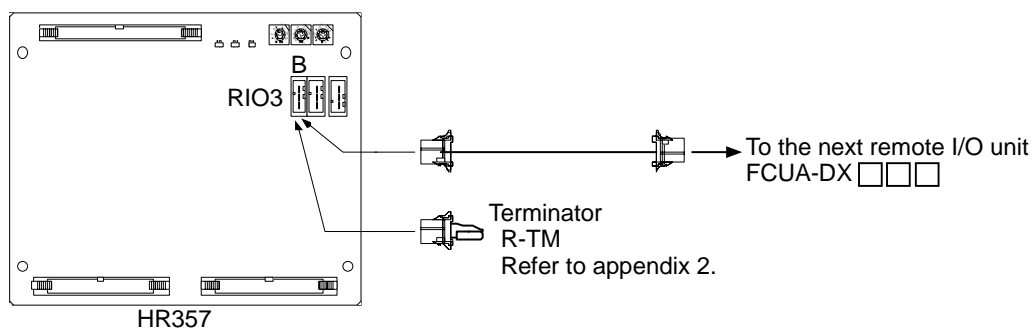



(3) Scan input (CF35)

An example is shown of a scan input circuit manufactured by the machine manufacturer. Refer to "8.3.2 (2) Pin assignment" for the connector pin assignments.

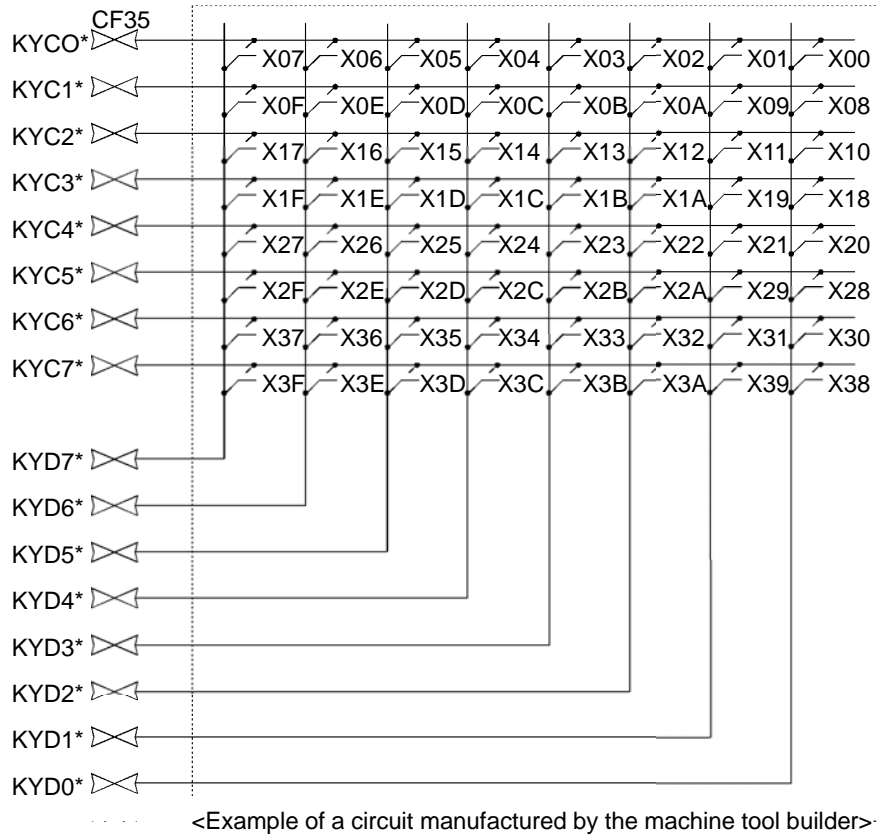

**(Note)** To scan input, connect a sneak path prevention diode as shown in the following drawing. The unit may not be able to read the correct input signals without a sneak path prevention diode installed.

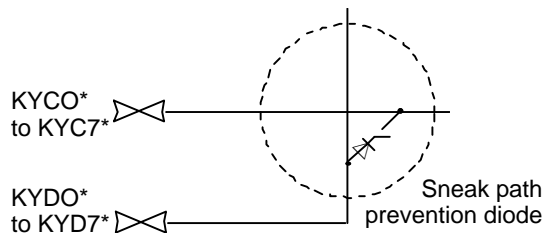

The common signals are changed over with scan input as shown in the following drawing. Key input data can be received when the common signal is LOW. The common signal changeover cycle is 11.68ms, but the input signal will not be recognized unless it is held for the ladder processing cycle time or longer.

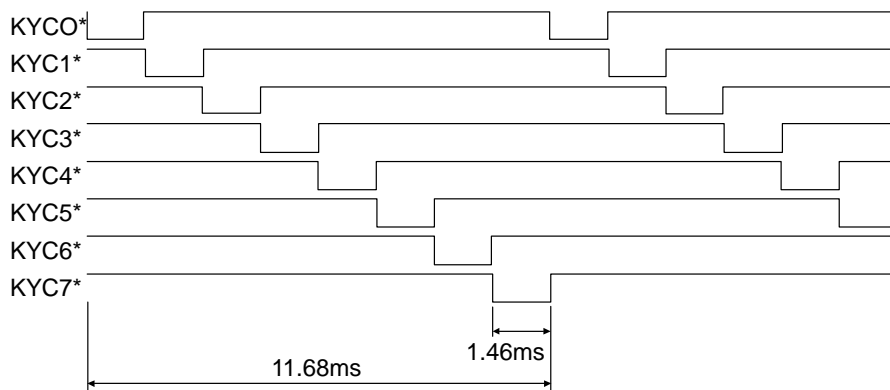

(4) Scan output (CF35)

An example is shown of a scan output circuit manufactured by the machine manufacturer. Refer to "8.3.2 (2) Pin assignment" for the connector pin assignments.

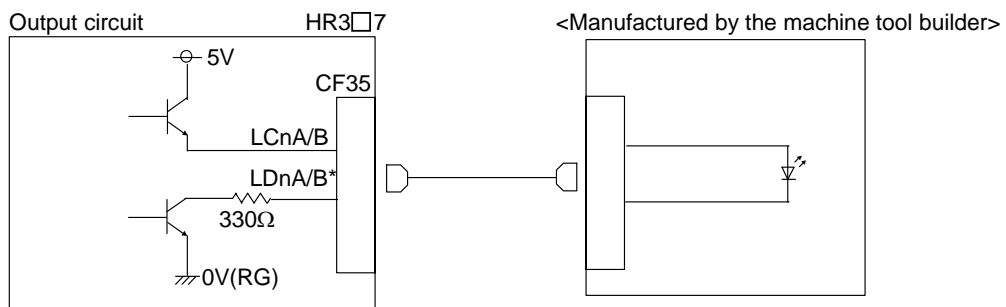
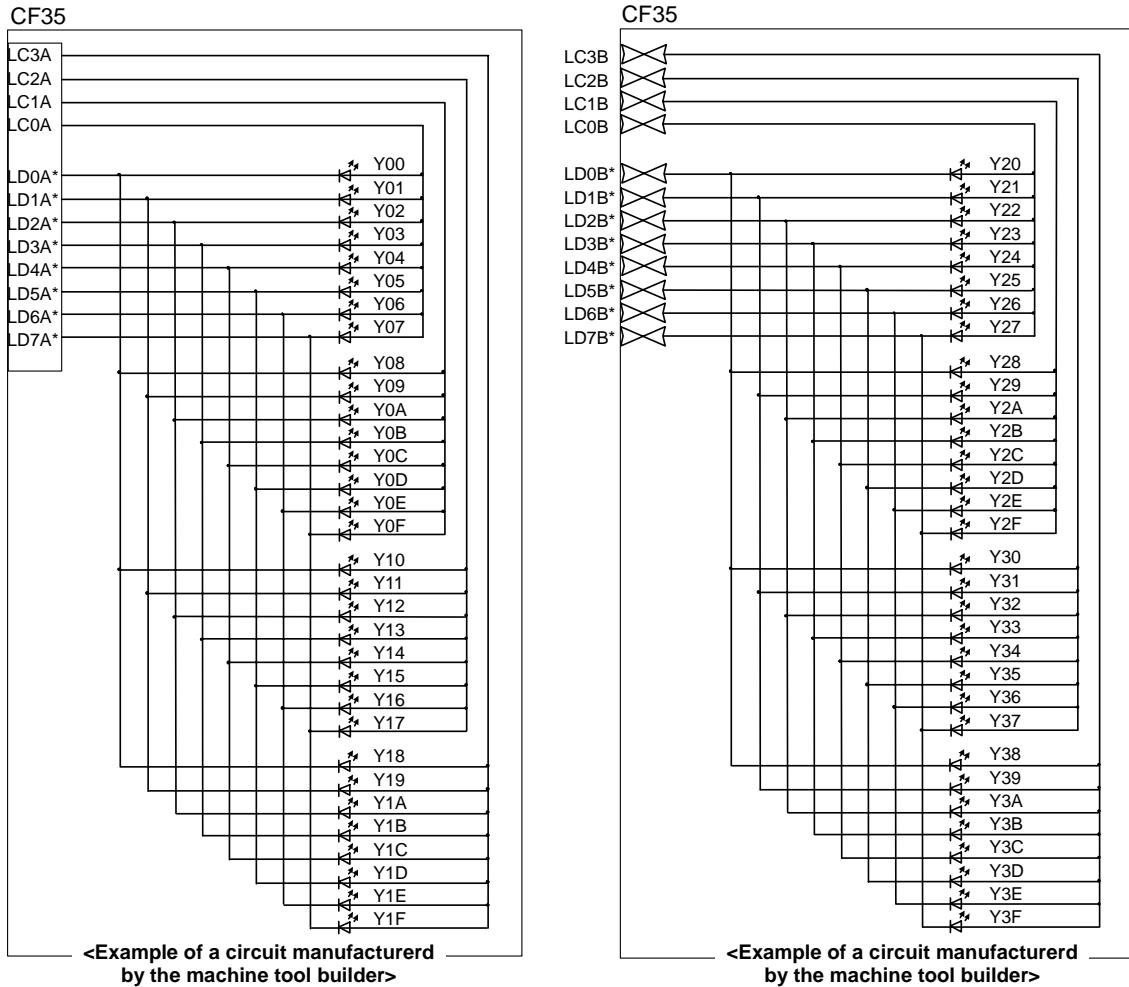

The common signals are changed over with scan output as shown in the following drawing. The LED outputs data, and lights only when the common signal is HIGH. The common signal changes to 4 signals in succession, and lights once every 5.84ms for 1.46ms only. The scan output is a 5V system.

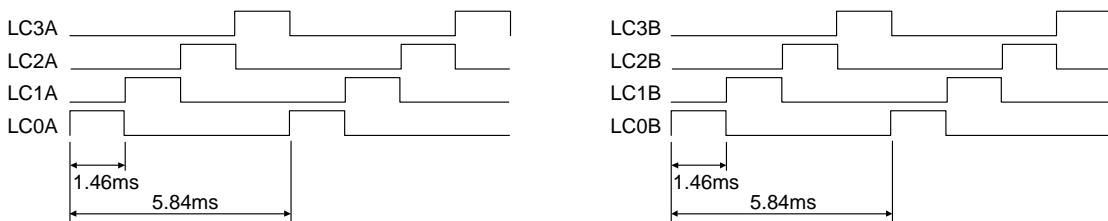

(5) Digital input (CF31)

A source type input circuit corresponding to source output is shown.

Sink type

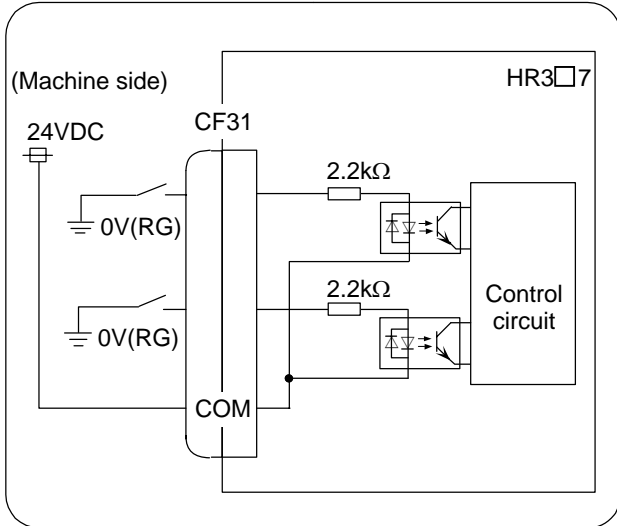

Source type

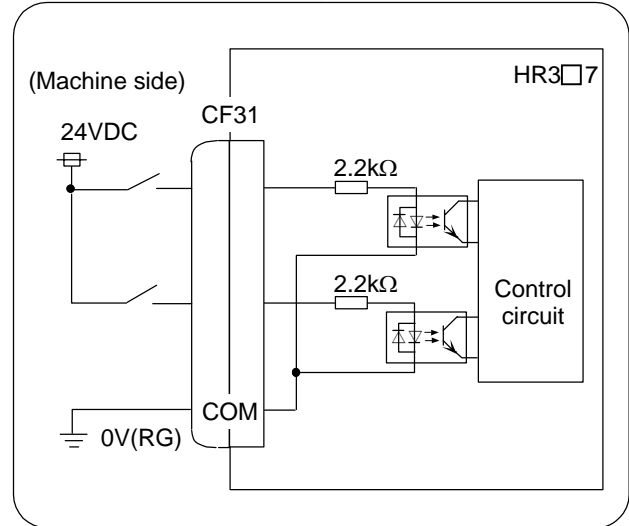

**Input conditions** Set so the input conditions are within the ranges shown in the following conditions.

		Sink type	Source type
1	Input voltage at external contact ON	6V or less	18V or more, 25.2V or less
2	Input current at external contact ON	9mA or more	
3	Input voltage at external contact OFF	20V or more, 25.2V or less	4V or less
4	Input current at external contact OFF	2mA or less	
5	Tolerable chattering time	3ms or less (Refer to T1 below)	
6	Input signal holding time	40ms or more (Refer to T2 below)	
7	Input circuit operation delay time	$3\text{ms} \leq T3 \leq T4 \leq 16\text{ms}$	
8	Machine side contact capacity	30V or more, 16mA or more	

**(Note)** Input signal holding time: 40ms or more as a guideline. The input signal can only be confirmed if held longer than the ladder process cycle time.

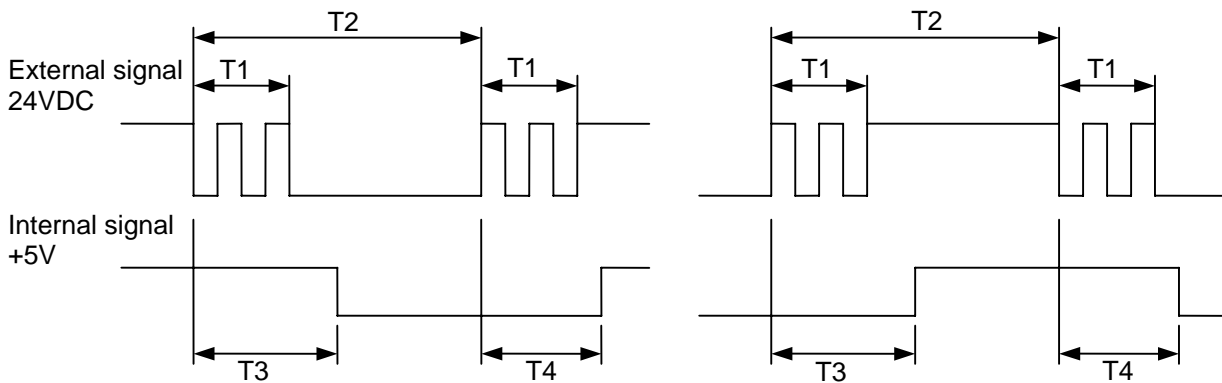

## (6) Digital output (CF33)

The HR357 output circuit is a source type (source output).

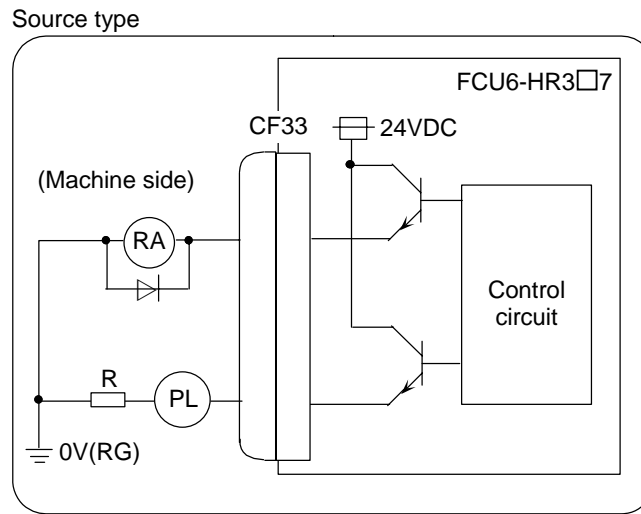

**CAUTION**

Do not apply any voltage to the connector other than that specified in this manual. Failure to observe this could cause bursting, damage, etc.

**Output conditions**

Insulation method	Non-insulation
Rated load voltage	24VDC
Max. output current	60mA/point
Saturation voltage	1.6V (standard)
Output delay time	40μs

**(Note 1)** When using an inductive load such as a relay, always connect a diode (voltage resistance 100V or more, 100mA or more) in parallel to the load.

**(Note 2)** When using a capacitive load such as a lamp, always connect a protective resistor ( $R=150\Omega$ ) serially to the load to suppress rush currents. (Make sure that the current is less than the above tolerable current including the momentary current.)

**8.4 Connecting with Card-sized I/O Card**

The card-sized I/O card can be used as the operation board I/O or electric cabinet I/O.

There are DI/DO type and AI/AO type for the card-sized I/O card. Refer to the following sections for details.

DI/DO type: "8.4.2 DI/DO Type Specifications"

AI/AO type: "8.4.3 AI/AO Type Specifications"

**8.4.1 Connection Example**

An example of card-sized I/O card connection is shown below.

Card-sized I/O card is connected to the operation panel I/O unit or control unit via the card-sized I/O card connector PCB. Card-sized I/O card connector PCB must be manufactured by the machine tool builder.

Connection example

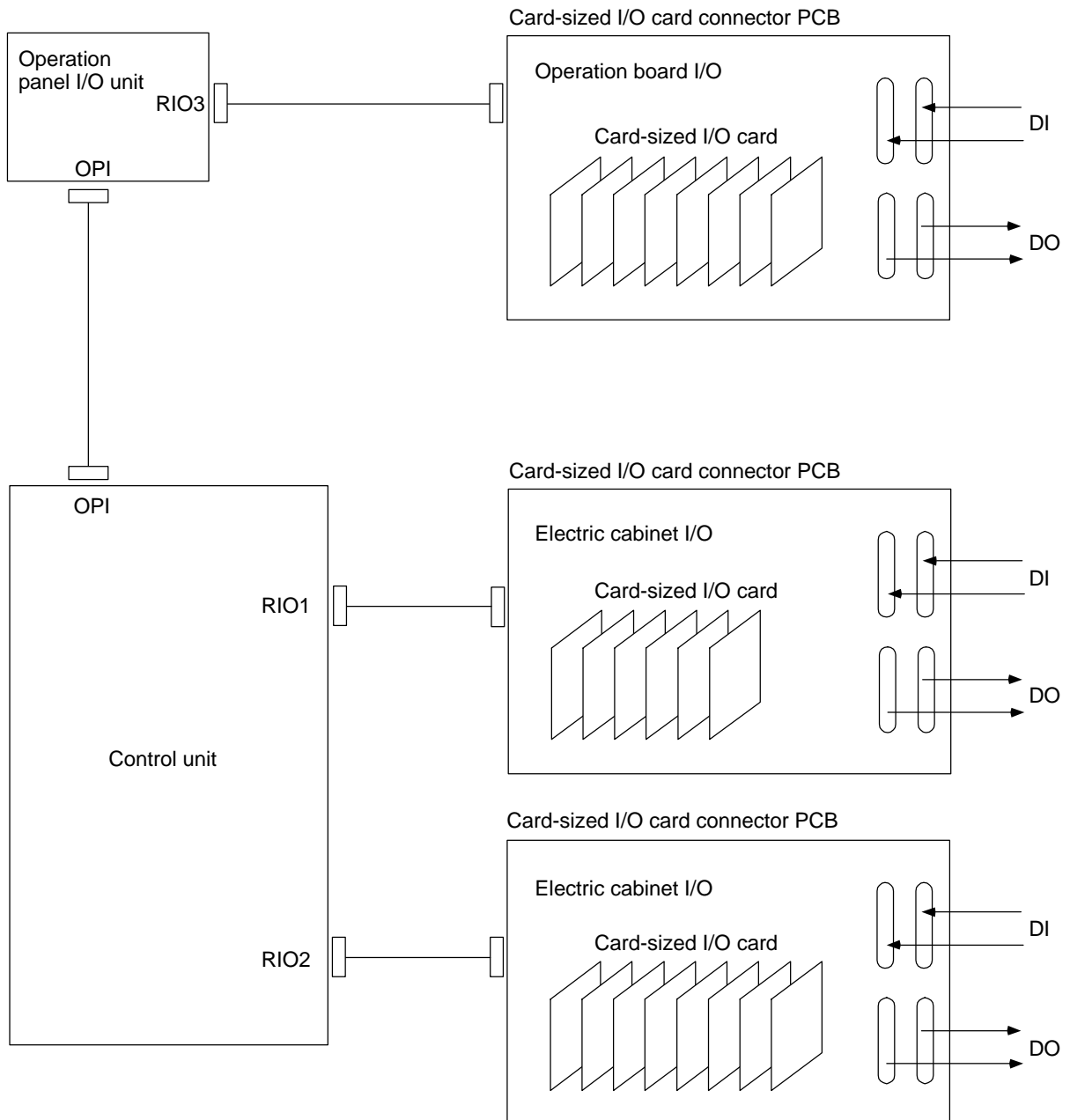

8.4.2 DI/DO Type Specifications

The card-sized I/O card (HR361/HR371) specifications are shown below.

- Input point and output points per card are 16 points each.
- Power supply (24VDC, 5VDC) is supplied from an external source.
- Multiple cards can be used.

Maximum number of cards differs depending on where the card-sized I/O card connector PCB is connected to:

- RIO1/RIO2: Max. 8 cards
- RIO3: Max. 5 cards

Outline drawing

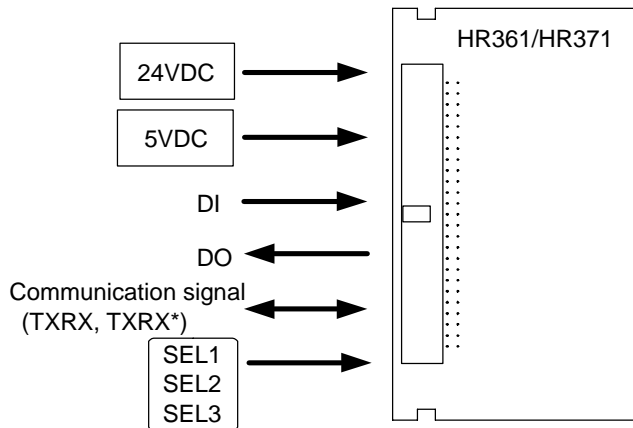

(1) Basic specifications

	HR361	HR371	Remarks
No. of input points	16 points		
No. of output points	16 points		
Input/output type (Note)	Sink type	Source type	
Outline dimension	55mm x 93mm		
Connector in use	7650-5002SC		Sumitomo 3M 50 pin
Recommended connector	9150-4500SC (Connector PCB side)		Sumitomo 3M 50 pin

(Note) The input and output share the same type.

(2) Setting the channel No.

Channel No. of the card-sized I/O card is set with CF30 of the card-sized I/O card connector PCB. Connect the signal pin to 5VDC or GND according to the chart below.

The card-sized I/O card occupies one channel per card.

Refer to "8.2.3 Setting of Station No. When Using Multiple Remote I/O Units" for the number of occupied channels.

Channel No. selection signal (pin No.)	Channel 1 CF30-1	Channel 2 CF30-2	Channel 3 CF30-3	Channel 4 CF30-4	Channel 5 CF30-5	Channel 6 CF30-6	Channel 7 CF30-7	Channel 8 CF30-8
SEL1(A3)	GND	DC5V	GND	DC5V	GND	DC5V	GND	DC5V
SEL2(B3)	GND	GND	DC5V	DC5V	GND	GND	DC5V	DC5V
SEL3(A4)	GND	GND	GND	GND	DC5V	DC5V	DC5V	DC5V

## (3) External power supply specifications

The power supply (24VDC, 5VDC) for the card-sized I/O card must be supplied from an external source. Prepare a power supply (stabilized power supply) that satisfies the following conditions per card.

	Voltage	Ripple/noise	Current
24VDC	24VDC±5%	240mVp-p	1A
5VDC	5VDC±5%	50mVp-p	0.4A

The output current is the value when 60mA x 16 points are used. Prepare a power supply that satisfies the total output current of the 24VDC output.

Refer to "Appendix 8. Precautions for Compliance to UL/c-UL Standards", as well.

## (4) Connector pin assignment

HR361/HR371 CF30

A			B		
1		GND	1		GND
2	I/O	TXRX*	2	I/O	TXRX
3	I	SEL1	3	I	SEL2
4	I	SEL3	4	I	24VDC
5	I	24VDC	5	I	24VDC
6		GND	6		GND
7	O	YF	7	O	Y7
8	O	YE	8	O	Y6
9	O	YD	9	O	Y5
10	O	YC	10	O	Y4
11	O	YB	11	O	Y3
12	O	YA	12	O	Y2
13	O	Y9	13	O	Y1
14	O	Y8	14	O	Y0
15		GND	15		GND
16	I	XF	16	I	X7
17	I	XE	17	I	X6
18	I	XD	18	I	X5
19	I	XC	19	I	X4
20	I	XB	20	I	X3
21	I	XA	21	I	X2
22	I	X9	22	I	X1
23	I	X8	23	I	X0
24		GND	24		GND
25	I	5VDC	25	I	5VDC

The signal assignment No. changes according to the station No. to be used. Refer to "PLC Interface Manual" for details.

## (5) Input/output circuit

## (a) Input circuit

The HR361 input circuit is a sink type, and the HR371 input circuit is a source type.

Sink type

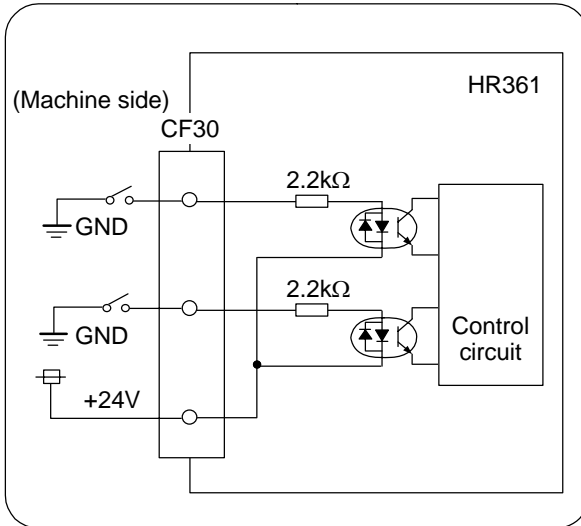

Source type

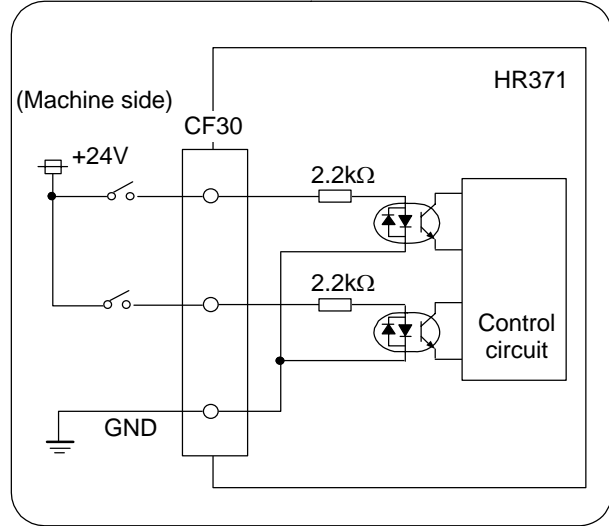

No COM pin is available used only for input; it is shared with 24VDC or GND.

### ⚠ CAUTION

- ⚠ Do not apply voltages to the connectors other than voltages indicated in this manual. Failure to observe this could cause the devices to rupture or damage, etc.
- ⚠ Incorrect connections could cause the devices to damage. Connect the cable to the designated connector.
- ⊘ Do not connect or disconnect the connection cables between each unit while the power is ON.



(b) Input conditions

Use the input signal within the following condition ranges.

	HR361	HR371
Input voltage when external contact is ON	6V or less	18V or more, 25.2V or less
Input current when external contact is ON	2mA or less	9mA or more
Input voltage when external contact is OFF	20V or more, 25.2V or less	4V or less
Input current when external contact is OFF	9mA or more	2mA or less
Tolerable chattering time (T1)	3ms or less	
Input signal hold time (T2)	40ms or more(*1)	
Input circuit operation delay time	$3\text{ms} \leq T3 \leq T4 \leq 20\text{ms}$	
Machine side contact capacity	30V or more, 16mA or more	

(\*1) Input signal hold time: 40ms or more is the guideline, and if not held for longer than the ladder processing cycle time, the input signal will not be recognized.

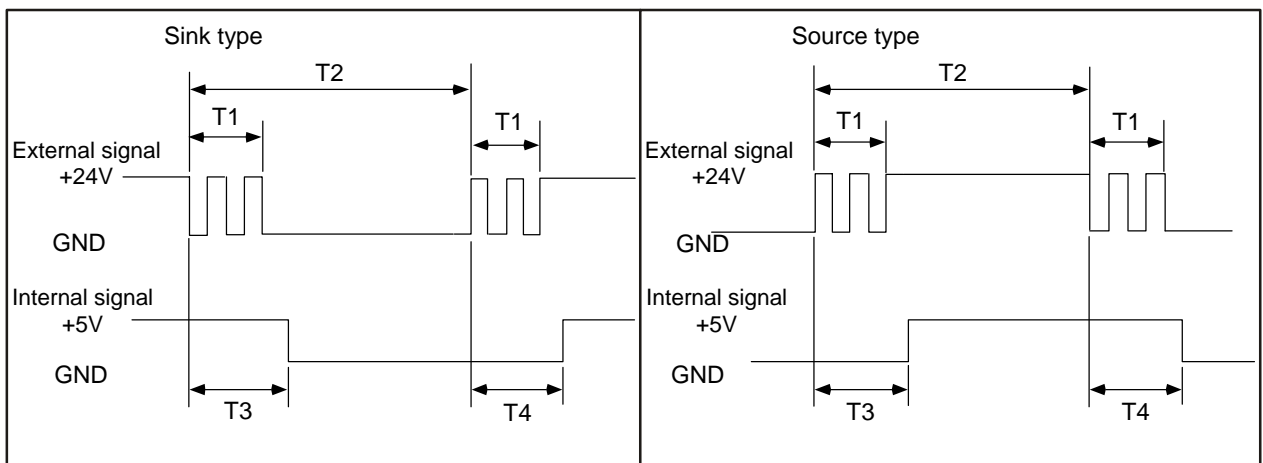

## (c) Output circuit

The HR361 output circuit is a sink type, and the HR371 output circuit is a source type.

Sink type

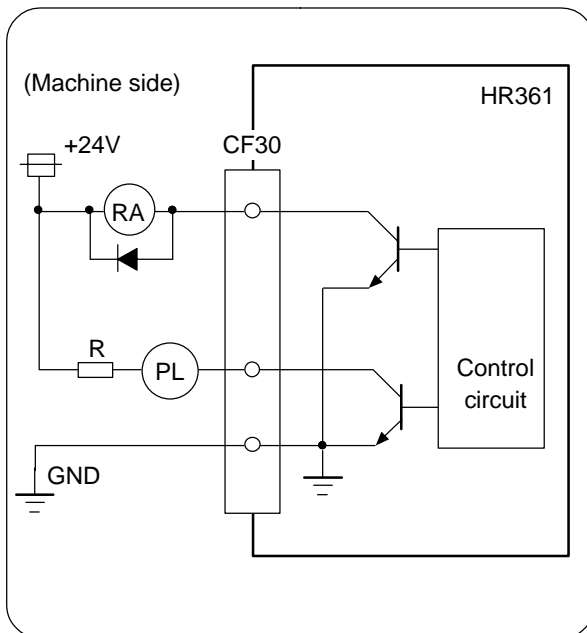

Source type

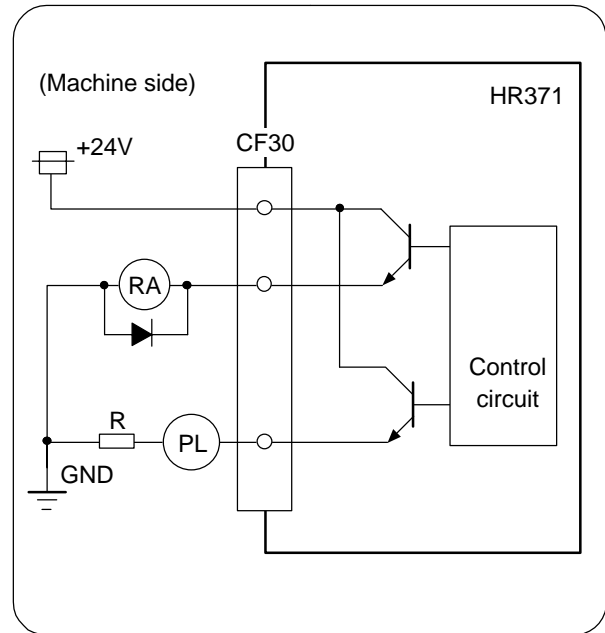

### CAUTION

- ⚠ Do not apply voltages to the connectors other than voltages indicated in this manual. Failure to observe this could cause the devices to rupture or damage, etc.
- ⚠ Incorrect connections could cause the devices to damage. Connect the cable to the designated connector.
- ⊘ Do not connect or disconnect the connection cables between each unit while the power is ON.

## (d) Output conditions

	HR361	HR371
Output current	60mA/point	
Saturated voltage	-	1.6V(standard)
Output delay time	40μs	

**(Note 1)** When using an inductive load such as relay, always connect a diode (withstand voltage 100V or more, 100mA or more) in parallel to the load.

**(Note 2)** When using a capacitive load such as lamp, always connect a protective resistor ( $R=150\Omega$ ) serially to the load to suppress rush currents. (Make sure that the current, including the instantaneous current, is less than the above tolerable current.)

8.4.3 AI/AO Type Specifications

The card-sized I/O card (HR381/HR383) specifications are shown below.

- HR381 card holds analog output 1ch.
- HR383 card holds analog input 4ch/analog output 1ch.
- Power supply (5VDC) is supplied from an external source.
- Multiple cards can be used.

Maximum number of cards differs depending on where the card-sized I/O card connector PCB is connected to.

- RIO1/RIO2: Max. 8 cards
- RIO3: Max. 5 cards

Outline drawing

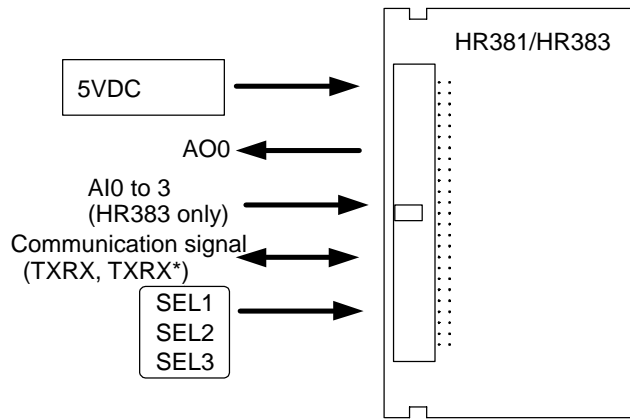

(1) Basic specifications

	HR381	HR383	Remarks
No. of input points	-	AI x 4ch	
No. of output points	AO x 1ch	AO x 1ch	
Outline dimension	55mm x 93mm		
Connector in use	7650-5002SC		Sumitomo 3M 50 pin
Recommended connector	9150-4500SC (Connector PCB side)		Sumitomo 3M 50 pin

(2) Setting the channel No.

Channel No. of the card-sized I/O card is set with CF30 of the card-sized I/O card connector PCB. Connect the signal pin to 5VDC or GND according to the chart below.

The card-sized I/O card occupies one channel per card.

Refer to "8.2.3 Setting of Station No. When Using Multiple Remote I/O Units" for the number of occupied channels.

Channel No. selection signal (pin No.)	Channel 1 CF30-1	Channel 2 CF30-2	Channel 3 CF30-3	Channel 4 CF30-4	Channel 5 CF30-5	Channel 6 CF30-6	Channel 7 CF30-7	Channel 8 CF30-8
SEL1(A3)	GND	DC5V	GND	DC5V	GND	DC5V	GND	DC5V
SEL2(B3)	GND	GND	DC5V	DC5V	GND	GND	DC5V	DC5V
SEL3(A4)	GND	GND	GND	GND	DC5V	DC5V	DC5V	DC5V

(3) External power supply specifications

The power supply (5VDC) for the card-sized I/O card must be supplied from an external source. Prepare a power supply (stabilized power supply) that satisfies the following conditions per card.

	Voltage	Ripple/noise	Current
5VDC	5VDC±5%	50mVp-p	0.4A

Refer to "Appendix 8. Precautions for Compliance to UL/c-UL Standards", as well.

(4) Connector pin assignment

HR381 CF36

A		B	
1	GND	1	GND
2	I/O TXRX*	2	I/O TXRX
3	I SEL1	3	I SEL2
4	I SEL3	4	reserve
5	reserve	5	reserve
6	GND	6	GND
7	reserve	7	reserve
8	reserve	8	reserve
9	reserve	9	reserve
10	reserve	10	reserve
11	reserve	11	reserve
12	reserve	12	reserve
13	reserve	13	reserve
14	reserve	14	O AOO
15	GND	15	GND
16	reserve	16	reserve
17	reserve	17	reserve
18	reserve	18	reserve
19	reserve	19	reserve
20	GND	20	reserve
21	GND	21	reserve
22	GND	22	reserve
23	GND	23	reserve
24	GND	24	GND
25	I 5VDC	25	I 5VDC

HR383 CF36

A		B	
1	GND	1	GND
2	I/O TXRX*	2	I/O TXRX
3	I SEL1	3	I SEL2
4	I SEL3	4	reserve
5	reserve	5	reserve
6	GND	6	GND
7	reserve	7	reserve
8	reserve	8	reserve
9	reserve	9	reserve
10	reserve	10	reserve
11	reserve	11	reserve
12	reserve	12	reserve
13	reserve	13	reserve
14	reserve	14	O AOO
15	GND	15	GND
16	reserve	16	reserve
17	reserve	17	reserve
18	reserve	18	reserve
19	reserve	19	reserve
20	GND	20	I AI3
21	GND	21	I AI2
22	GND	22	I AI1
23	GND	23	I AI0
24	GND	24	GND
25	I 5VDC	25	I 5VDC

The signal assignment No. changes according to the station No. to be used. Refer to "PLC Interface Manual" for details.

## (5) Input/output circuit

## (a) Input/output circuit

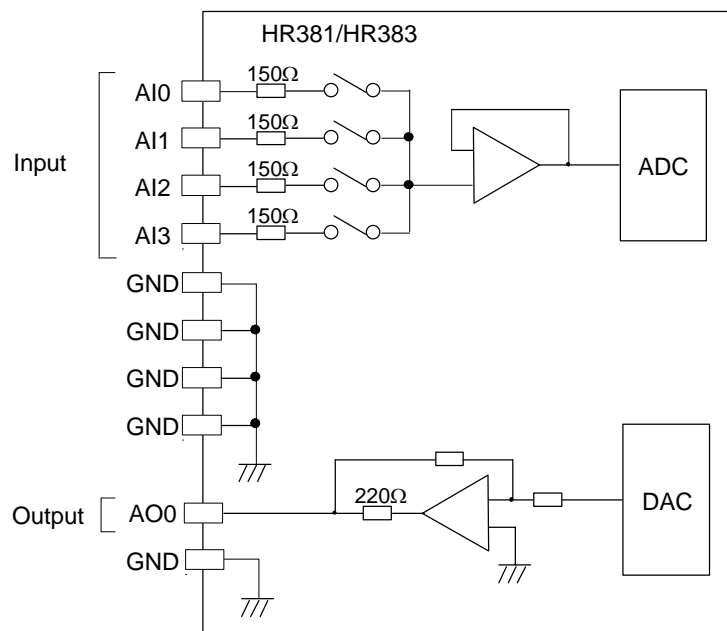

## (b) Input conditions

Max. input rating	±15V
Resolution	10V/200(5mV)
Precision	Within ±25mV
Input sampling time	14.2ms(AI0)/42.6ms(AI1 to 3)

## (c) Output conditions

Output voltage	-10V to +10V(±5%)
Resolution	12bit(±10V x n/4096) (n=20 to 211)
Load conditions	10kΩ load resistance
Output impedance	220Ω

### ⚠ CAUTION

- ⚠ Do not apply voltages to the connectors other than voltages indicated in this manual. Failure to observe this could cause the devices to rupture or damage, etc.
- ⚠ Incorrect connections could cause the devices to damage. Connect the cable to the designated connector.
- ⊘ Do not connect or disconnect the connection cables between each unit while the power is ON.

## 8.4.4 Precautions for Wiring

## (1) Connection of terminator

A terminator is required between the communication signal cables (TXRX, TXRX\*) of the card-sized I/O. Connect a terminator to the card-sized I/O card connector PCB signal line as shown below.

Recommended terminator:  $100\Omega \pm 1\%$  1/4W (RN14C2E101F) [Koa Denko]

(Example) When four connectors are installed on the card-sized I/O card connector PCB.

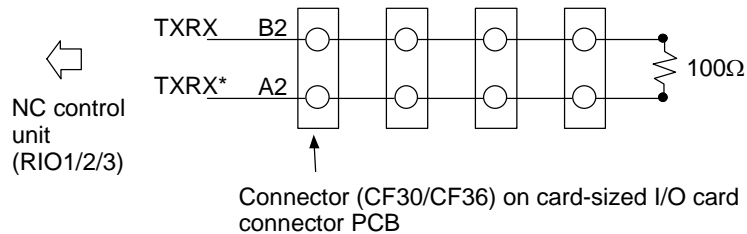

## (2) Shield treatment of communication signal cable

Because the card-sized I/O card communication cables (TXRX, TXRX\*) communicate at a high speed, they must be wired separately from other signal cables. Shield each end of the signal with a GND pattern as shown below, and ground at several places.

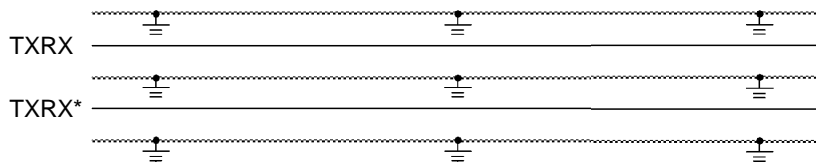

(3) Installation direction

Install the card-sized I/O card in the direction as shown in "installation 1" or "installation 2" below.

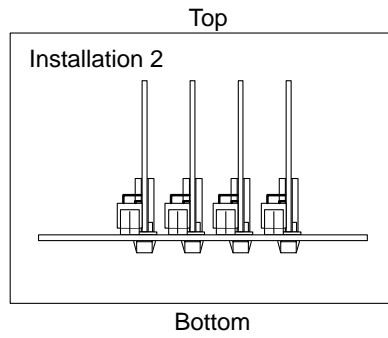
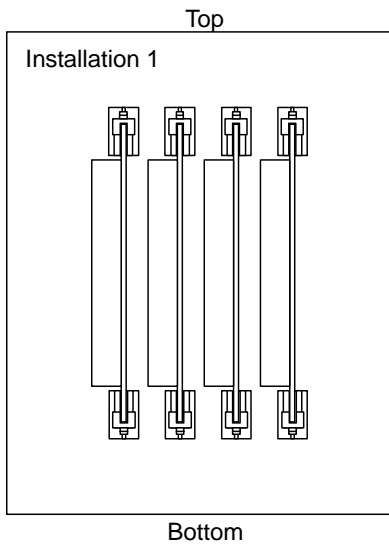

**(Note)** If the card-sized I/O card is installed horizontally, the heat will build up. So, do not install the card as shown below.

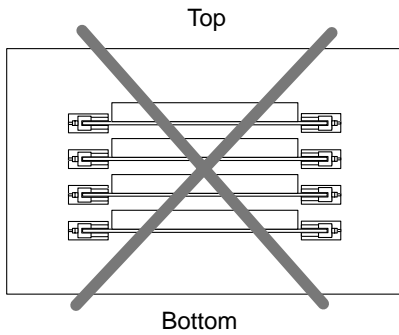

(4) Installation spacing

The card-sized I/O card installation spacing must be 15mm or more.

8.5 Connecting with Expansion I/O Card QY231

8.5.1 Outline

QY231 is the machine input/output and operation board input/output card for connecting with the remote I/O communication (MC link B) of the control unit, or the remote I/O communication of the operation panel I/O unit remote I/O communication or communication terminal remote I/O communication (MC link B).

Compatible machine control signals	No. of occupied stations
Digital input signal (DI) : 64 points (photocoupler insulation) sink/source shared type	2
Digital output signal (DO) : 48 points (non-insulation) source type	

8.5.2 Hardware Interface

(1) Connector layout diagram

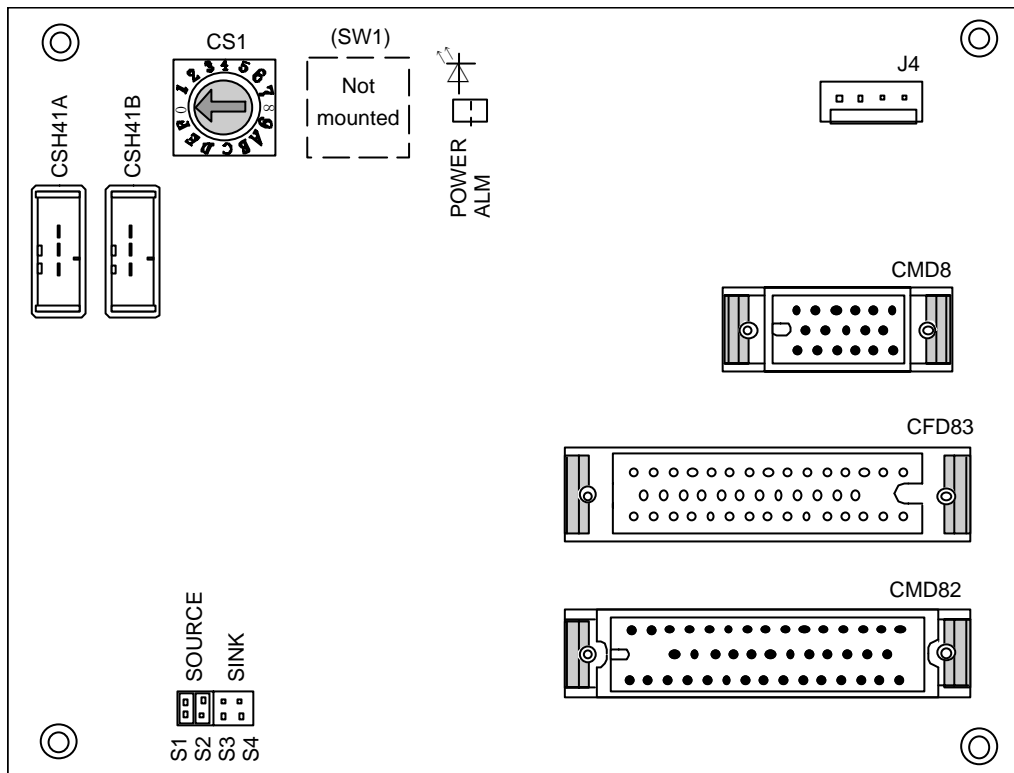



(2) Pin assignments

Remote I/O unit connection terminal  
CSH41A/B

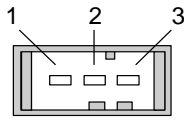

<Cable side connector type>  
Connector: 1-178288-3  
Contact: 1-175218-2 x3  
Recommended manufacturer: Tyco Electronics AMP

1	I/O	TXRX
2	I/O	TXRX*
3		0V(RG)

Power input terminal (24VDC)  
J4

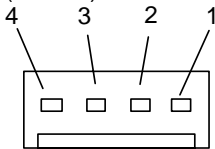

<Cable side connector type>  
Connector: 51191-0400  
Contact: 50802-8100 x4  
Recommended manufacturer: MOLEX

1		0V(RG)
2	I	24VDC
3	I	24VDC
4		0V(RG)

Machine input terminal  
CMD81/CMD82

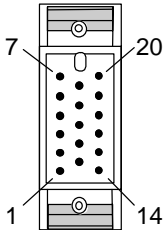

<Cable side connector type>  
Connector: MRP20F01  
Contact: MRP-F102  
Case: MR20W  
Recommended manufacturer: HONDA TSUSHIN KOGYO

CMD81

7	0V(RG)	13		20	DC24V
6		12	X36	19	X37
5	X35	11	X33	18	X34
4	X32	10	X30	17	X31
3	X3F	9	X3D	16	X3E
2	X3C	8	X3A	15	X3B
1	X39			14	X38

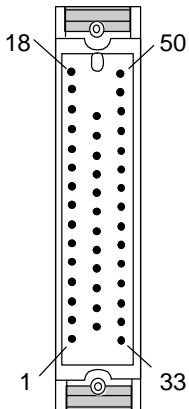

<Cable side connector type>  
Connector: MRP50F01  
Contact: MRP-F102  
Case: MR50W  
Recommended manufacturer: HONDA TSUSHIN KOGYO

CMD82

18	0V(RG)			50	X27
17	X26			49	X25
16	X24	32	X22	48	X23
15	X21	31	X2F	47	X20
14	X2E	30	X2C	46	X2D
13	X2B	29	X29	45	X2A
12	X28	28	X16	44	X17
11	X15	27	X13	43	X14
10	X12	26	X10	42	X11
9	X1F	25	X1B	41	X1E
8	X1D	24	X18	40	X1C
7	X1A	23	X05	39	X19
6	X07	22	X02	38	X06
5	X04	21	X0F	37	X03
4	X01	20	X0C	36	X00
3	X0E	19	X09	35	X0D
2	X0B			34	X0A
1	X08			33	DC24V

CS1



0 \* This example shows CS1 set to "0". Refer to "PLC Interface Manual" for details.

Machine output terminal  
CFD83

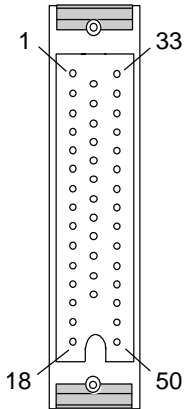

<Cable side connector type>  
Connector: MRP50M01  
Contact: MRP-M102  
Case: MR50W  
Recommended manufacturer:  
HONDA TSUSHIN KOGYO

CFD83					
1	Y08			33	DC24V
2	Y0B			34	Y0A
3	Y0E	19	Y09	35	Y0D
4	Y01	20	Y0C	36	Y00
5	Y04	21	Y0F	37	Y03
6	Y07	22	Y02	38	Y06
7	Y1A	23	Y05	39	Y19
8	Y1D	24	Y18	40	Y1C
9	Y1F	25	Y1B	41	Y1E
10	Y12	26	Y10	42	Y11
11	Y15	27	Y13	43	Y14
12	Y28	28	Y16	44	Y17
13	Y2B	29	Y29	45	Y2A
14	Y2E	30	Y2C	46	Y2D
15	Y21	31	Y2F	47	Y20
16	Y24	32	Y22	48	Y23
17	Y26			49	Y25
18	0V(RG)			50	Y27

CS1



\* This example shows CS1 set to "0".  
Refer to "PLC Interface Manual" for details.

**(3) Rotary switch**

Set the address (station No.) assignment for two stations in DI/DO: 64/48 point units. Set using the CS1 rotary switch. The assignment address is changed with the rotary switch setting.

CS1

Setting	Function
0	Remote I/O station 0, 1 station selection
1	Invalid
2	Remote I/O station 2, 3 station selection
3	Invalid
4	Remote I/O station 4, 5 station selection
5	Invalid
6	Remote I/O station 6, 7 station selection
7	Invalid
8~F	Setting prohibited



CS1

\* The X○ and Y○ assignments are reference values. When actually making the assignment, add DI/DO assignment No. to the head address assigned to each remote IO unit station No.

**(4) Setting switches**

Set the digital input sink type and source type changeover.

S1, S2	S3, S4	Function
ON	OFF	Source input selection
OFF	ON	Sink input selection

8.5.3 Connections

(1) External power supply (DCIN)

24VDC is required for card operation. Prepare a stabilized power supply that satisfies the following specifications.

Rated output: DC24V±5%  
 Ripple: 240mV (P-P)  
 Rated current: 3.8A

\* The rated output current is the value when using 60mA × 48 points for the machine output (DO). Prepare a power supply that satisfies the 24VDC output's total output current.

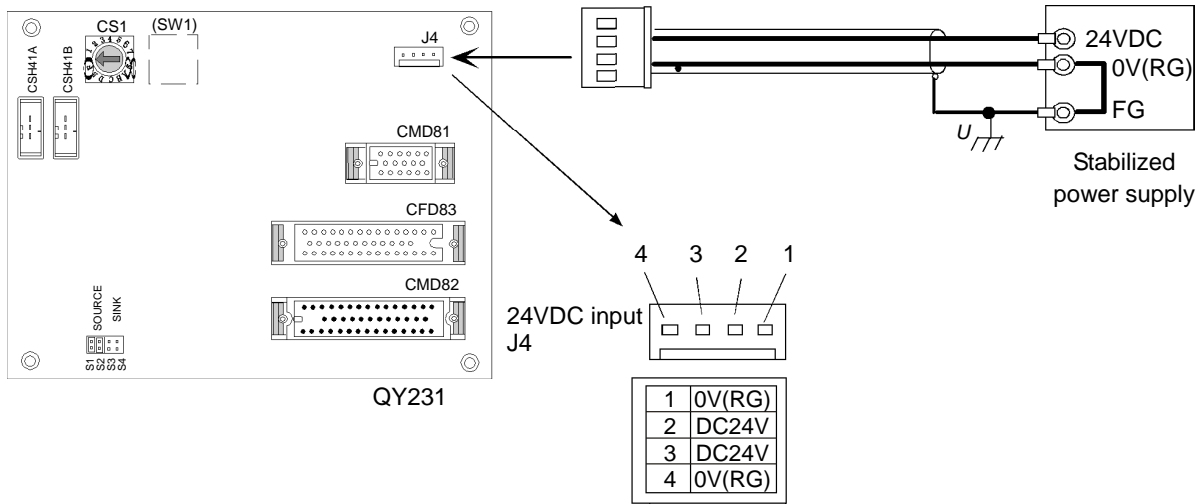

(Note) Cables for the J4 connector must be manufactured by the machine tool builder.

(2) Remote I/O connections (CSH41A/B)

(a) Connection of the CSH41A connector

Connect the CSH41A connector to the RIO1/RIO2 connector of the control unit, or RIO3 connector of the operation panel I/O unit.

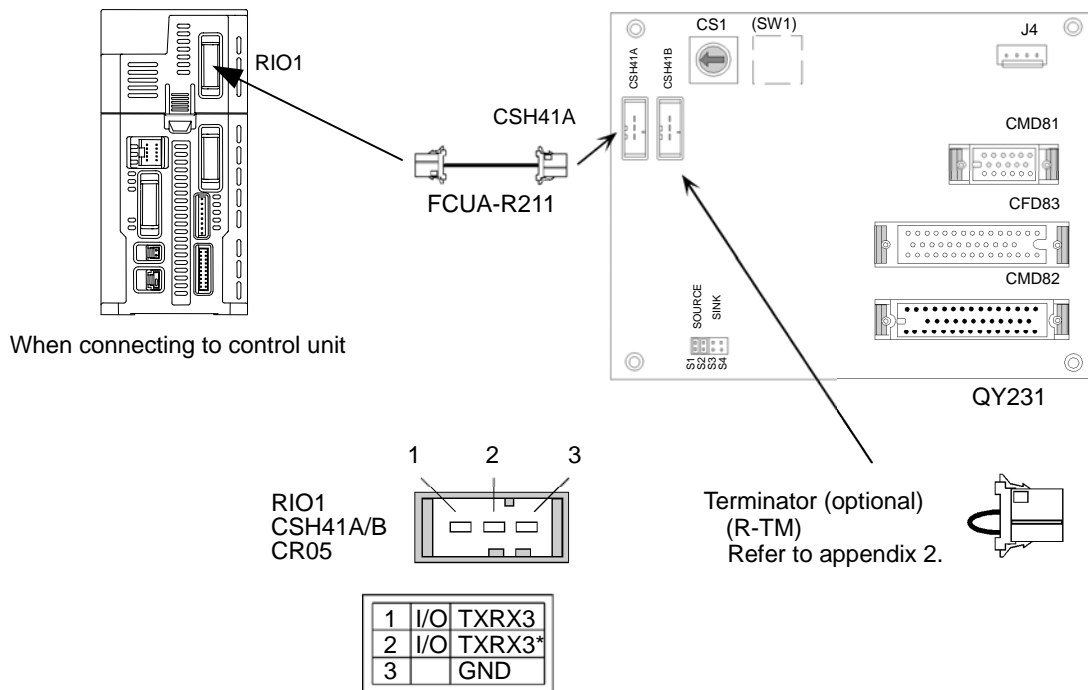

**(3) Machine input terminal (CMD81, CMD82)**

The following shows the sink type input circuit corresponding to the machine side sink output, and source type input circuit corresponding to the machine side source output.

Sink type

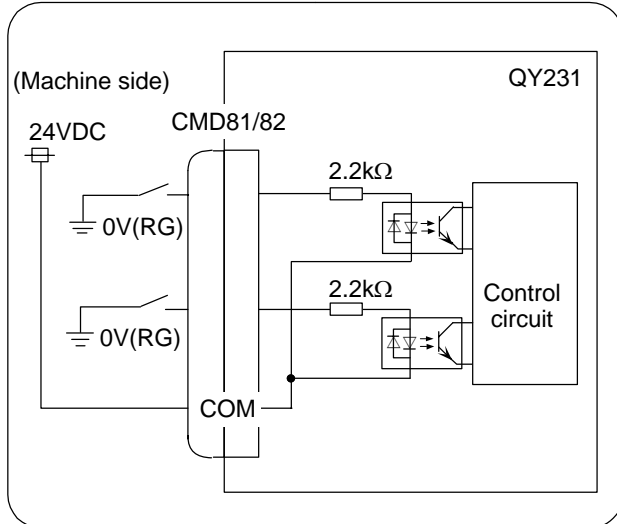

Source type

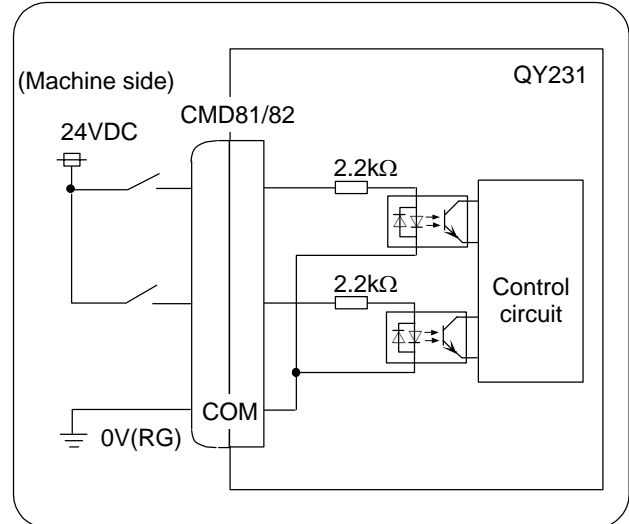
**⚠ CAUTION**

⚠ Do not apply any voltage to the connector other than that specified in this manual. Failure to observe this could cause bursting, damage, etc.

**Input conditions**

Set so the input conditions are within the ranges shown in the following conditions.

		<b>Sink type</b>	<b>Source type</b>
1	Input voltage at external contact ON	6V or less	18V or more, 25.2V or less
2	Input current at external contact ON	9mA or more	
3	Input voltage at external contact OFF	20V or more, 25.2V or less	4V or less
4	Input current at external contact OFF	2mA or less	
5	Tolerable chattering time	3ms or less (Refer to T1 below.)	
6	Input signal holding time	40ms or more (Refer to T2 below.)	
7	Input circuit operation delay time	3ms T3 ≐ T4 16ms	
8	Machine side contact capacity	30V or more, 16mA or more	

**(Note)** Input signal holding time: 40ms or more as a guideline. The input signal can only be confirmed if held longer than the ladder process cycle time.

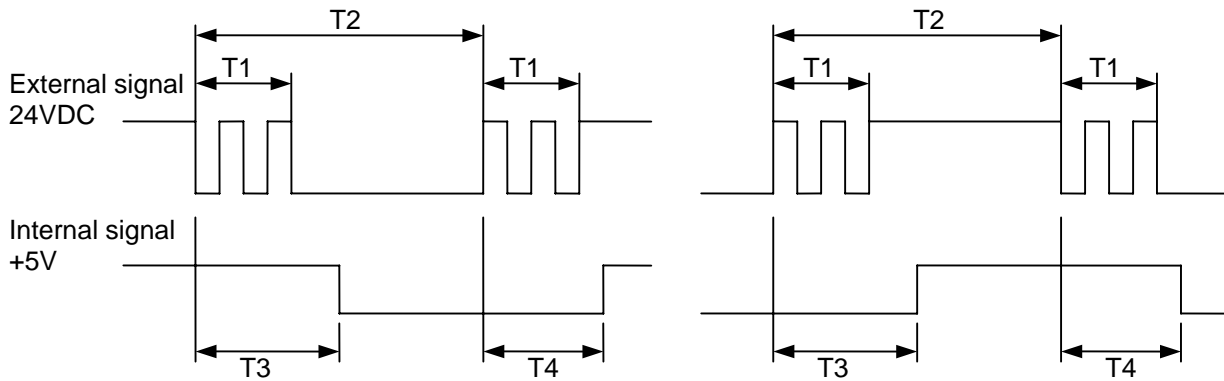

**(4) Machine output terminal (CFD83)**

The QY231 output circuit is a source type.

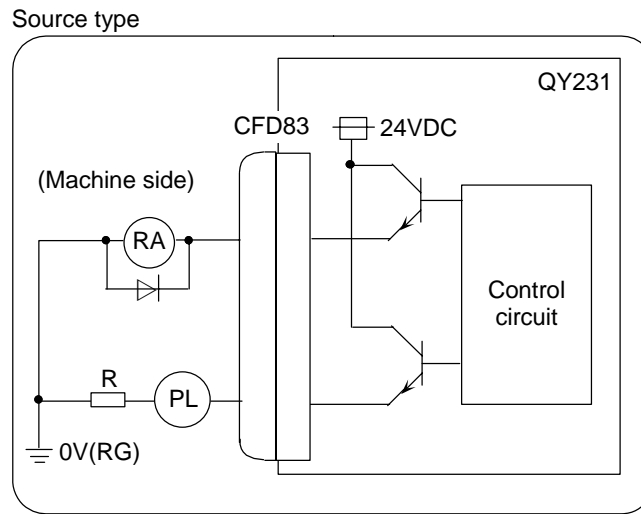
**⚠ CAUTION**

⚠ Do not apply any voltage to the connector other than that specified in this manual. Failure to observe this could cause bursting, damage, etc.

**Output conditions**

Insulation method	Non-insulation
Rated load voltage	24VDC
Max. output current	60mA/point
Saturation voltage	1.6V (standard)
Output delay time	40μs

**(Note 1)** When using an inductive load such as a relay, always connect a diode (voltage resistance 100V or more, 100mA or more) in parallel to the load.

**(Note 2)** When using a capacitive load such as a lamp, always connect a protective resistor ( $R = 150\Omega$ ) serially to the load to suppress rush currents. (Make sure that the current is less than the above tolerable current including the momentary current.)

**(a) Connection of the remote I/O unit**

When the remote I/O unit is connected with a serial link, multiple units can be combined and used in a range of eight or less total occupied stations. (Refer to the section "8.2 Connecting with Remote I/O Unit" for details.)

QY231 occupies two stations, so the remote I/O units including this card can be connected to RIO1 of the control unit in combinations of 6 stations or less.

Connect a terminator R-TM to the CSH41B when it is not connected to any device.

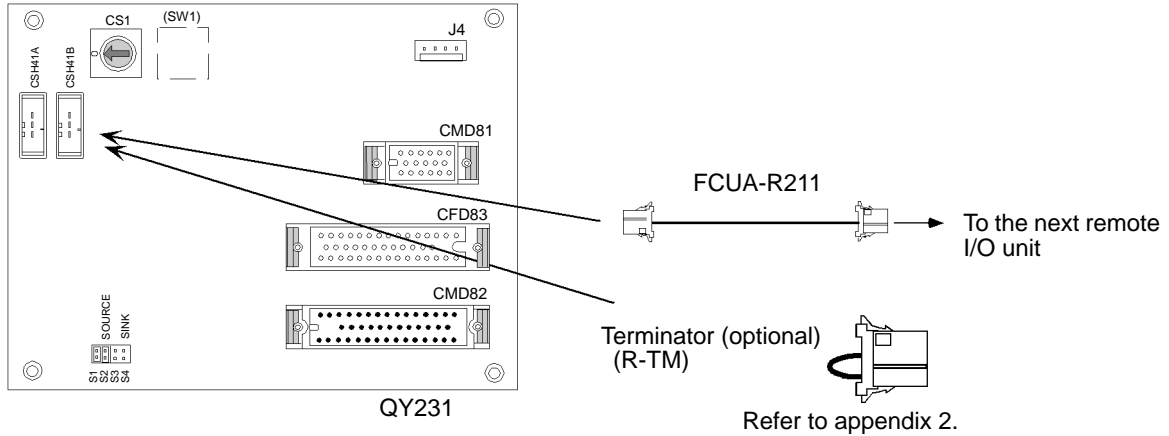

## 9. Connections of Display Unit

The method for connecting to each unit and device from the display unit are briefly explained in this section.

### 9.1 Display Unit Connection System Drawing

#### 9.1.1 FCU7-DA201-11 / FCU7-DA211-11

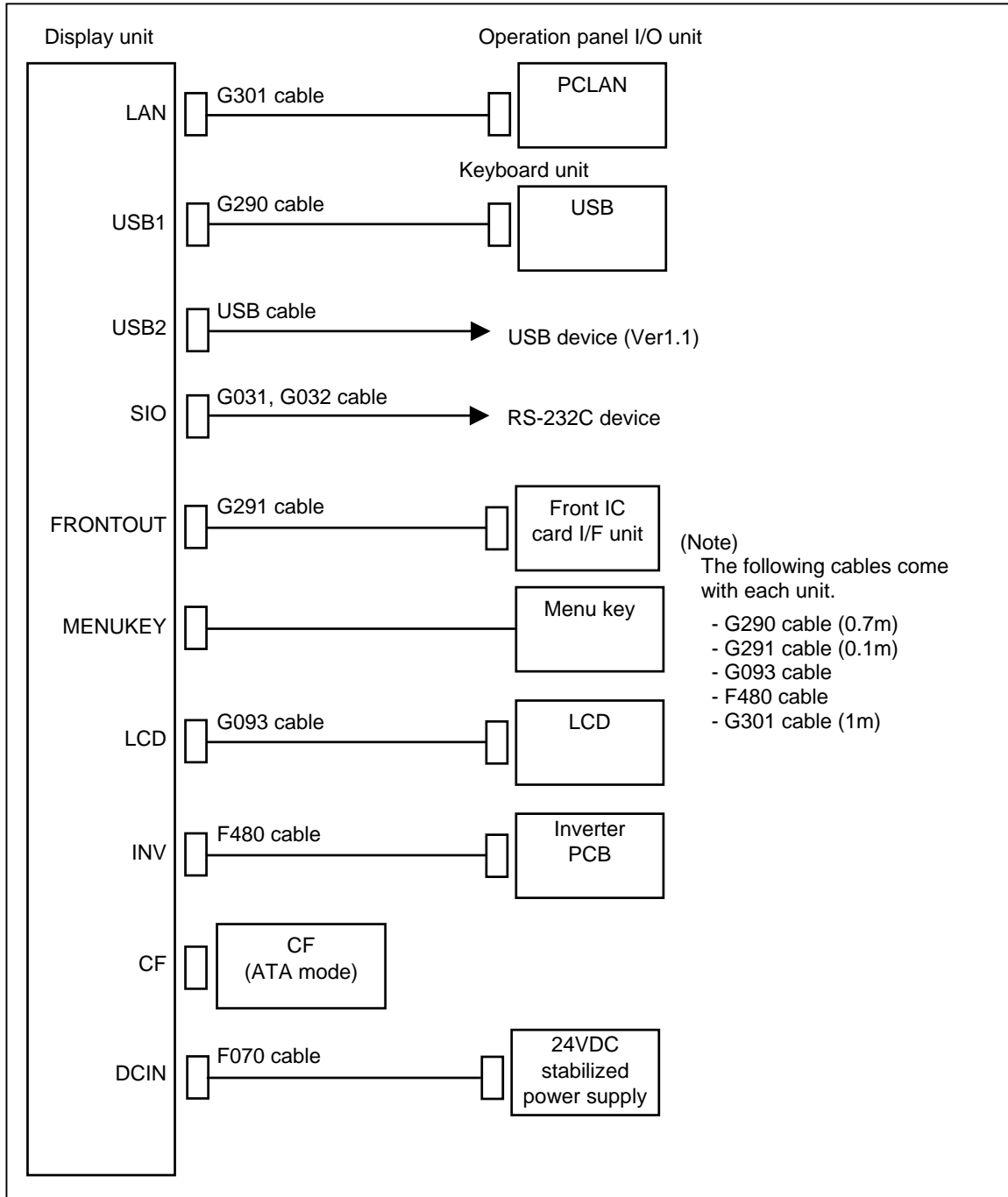

**(Note)** When connecting commercially available devices, refer to the section "Appendix 9. Precautions for Use of Peripheral Devices and Commercially Available Devices".



9.1.2 FCU7-DA315-11 / FCU7-DA415-11 / FCU7-DA445-11

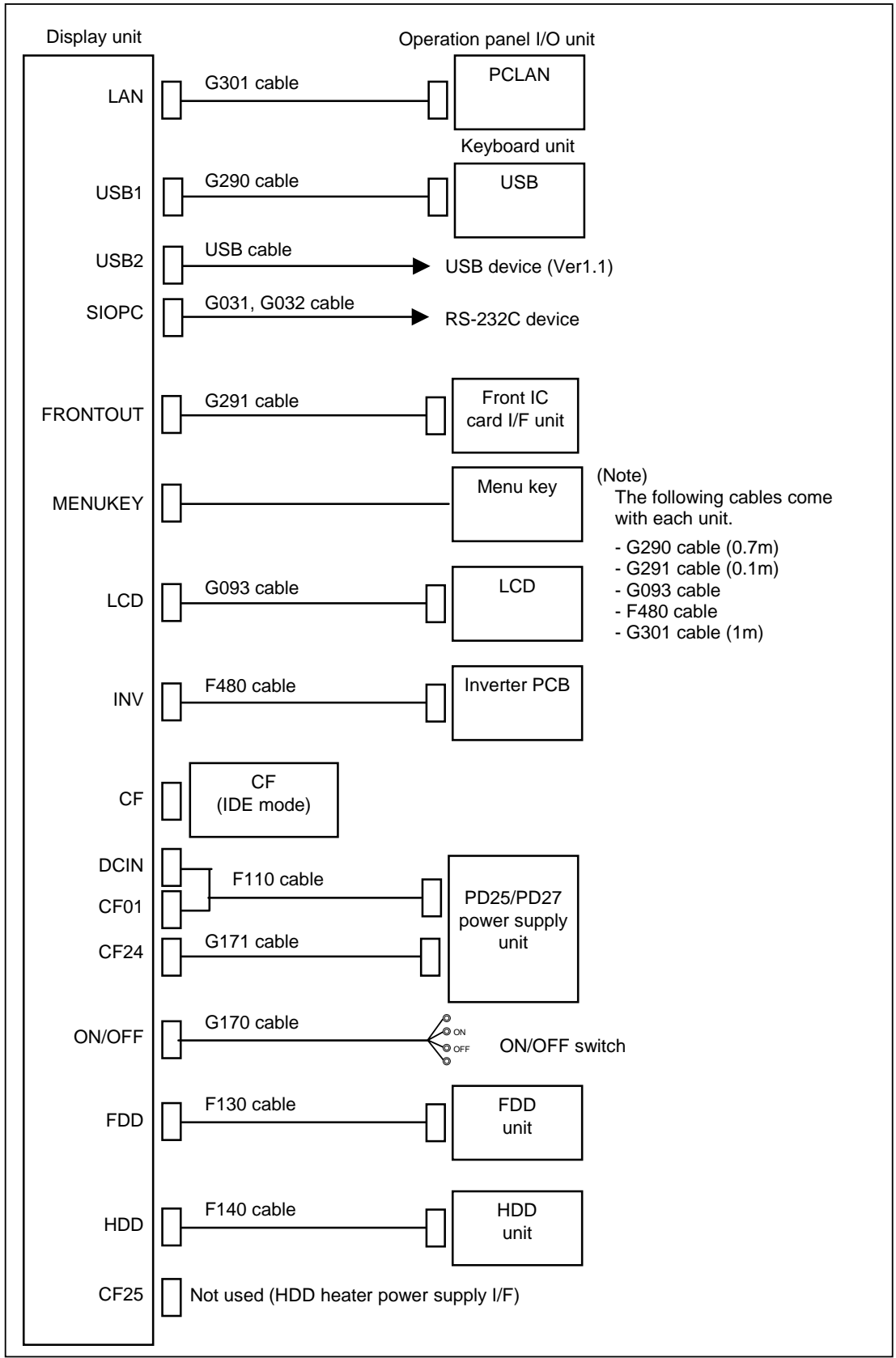

**(Note)** When connecting commercially available devices, refer to the section "Appendix 9. Precautions for Use of Peripheral Devices and Commercially Available Devices".

## 9.2 Connecting with Power Supply

Depending on the type of display unit, power supply to be connected differs.

Display unit	Power supply
FCU7-DA2□□-□□	General-purpose 24VDC stabilized power supply or PD25/PD27 power supply unit
FCU7-DA3□□-□□ FCU7-DA4□□-□□	PD25/PD27 power supply unit (Note) Controlling with ACFAIL signal is necessary; therefore, general-purpose stabilized power supply cannot be used.

9.2.1 FCU7-DA201-11 / FCU7-DA211-11 (When using general-purpose 24VDC stabilized power supply)

(1) Connection of power supply

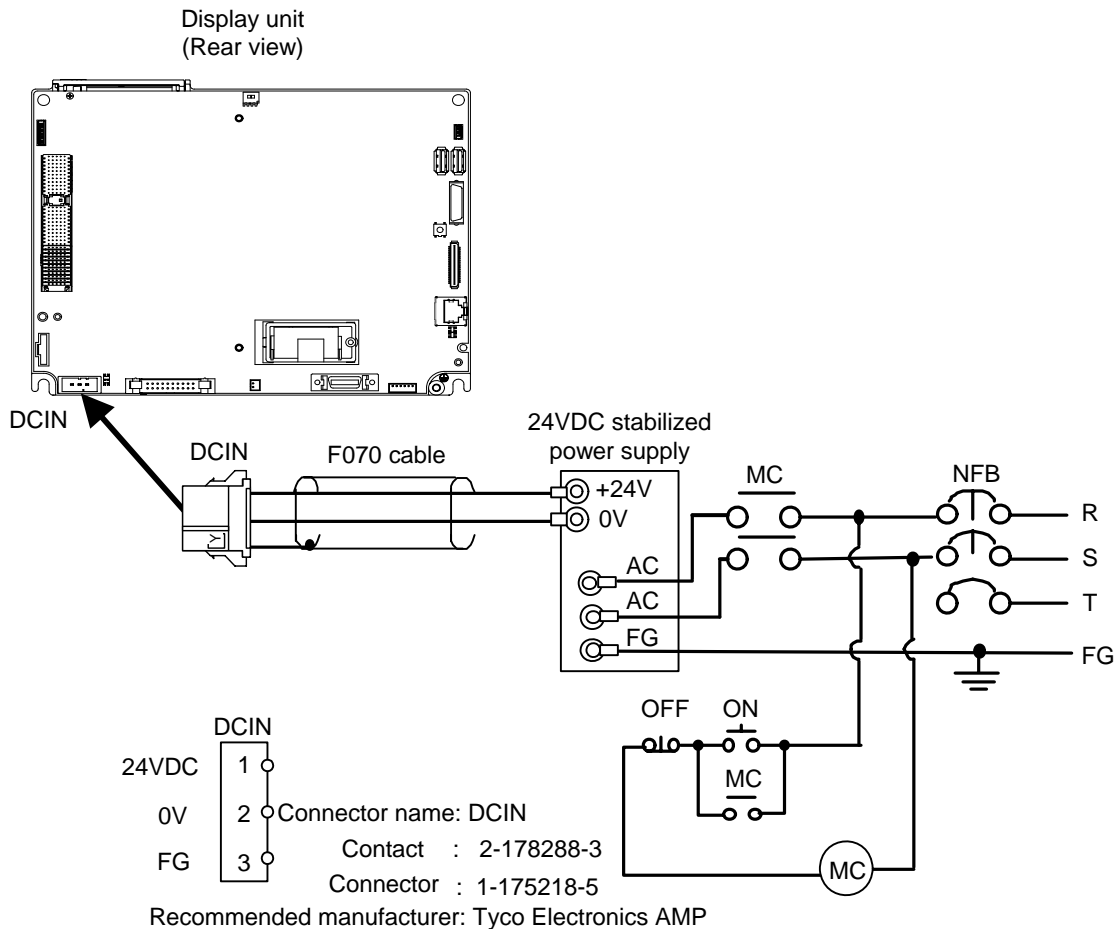

<Related items>

Cable drawing: "Appendix 2 (F070 cable)"

Connector pin assignment: "Appendix 3 (DCIN connector)"

**(Note)** When 24V power is supplied to the display unit under the following conditions, welding may occur on the contacts due to rush current; so be careful.

When 24VDC's ON/OFF are directly controlled by a magnetic switch such as relay AND  
When heat capacity of the contacts for relay, etc. used to control 24VDC's ON/OFF is small.

(2) Specifications of power supply

When selecting the stabilized power supply (prepared by machine tool builder), consider the characteristics indicated in the section "6.2.1 When Using General-Purpose 24VDC Stabilized Power Supply". Use a power supply that complies with CE Marking or that follows the safety standards.

**CAUTION**

- ⚠ Do not apply voltages to the connectors other than voltages indicated in this manual. Failure to observe this could cause the devices to rupture or damage, etc.
- ⚠ Incorrect connections could cause the devices to damage. Connect the cable to the designated connector.
- ⚠ Do not connect or disconnect the connection cables between each unit while the power is ON.

9.2.2 FCU7-DA201-11 / FCU7-DA211-11 (When using PD25/PD27 power supply unit)

(1) Connections of PD25/PD27 power supply

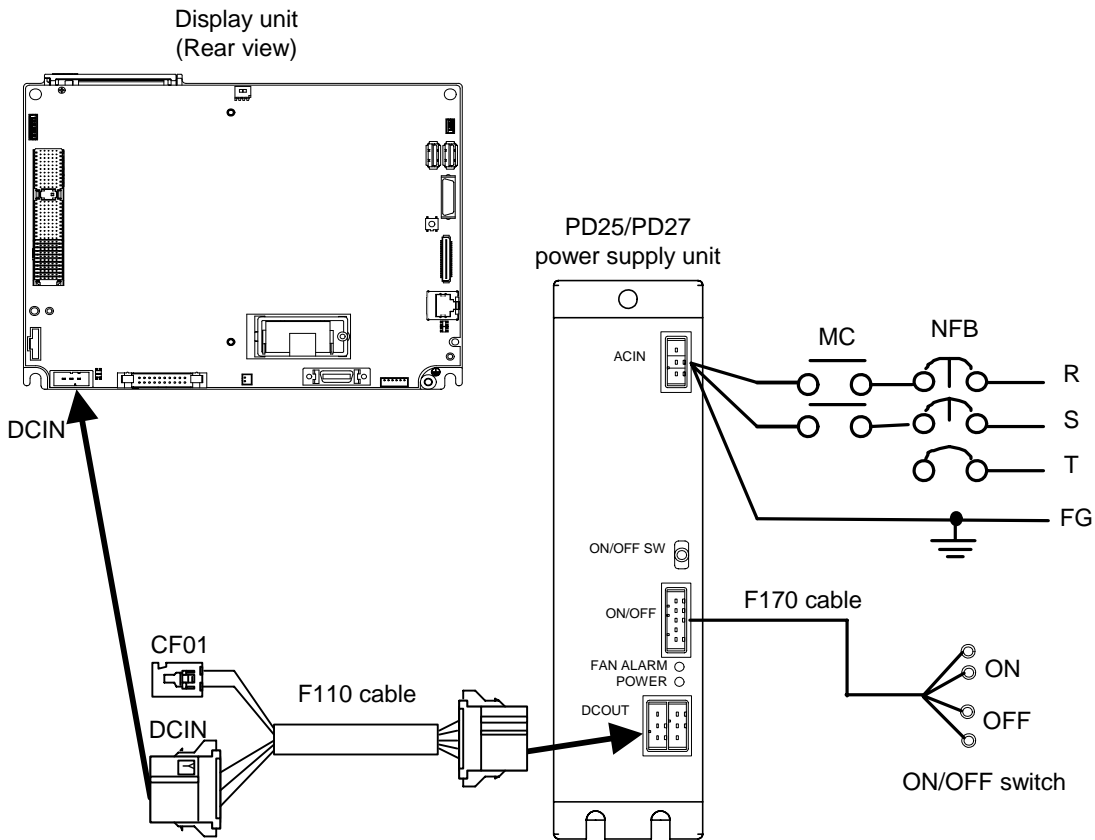

**(Note 1)** CF01 (ACFAIL input: power supply shutoff notification signal) will not be used. Leave it unconnected.

**(Note 2)** PD25/PD27 cannot be turned ON immediately after it is turned OFF. Wait at least 2 seconds, and then turn the power ON.

<Related items>

Cable drawing: "Appendix 2 (F110 cable, F170 cable)"

Connector pin assignment: "Appendix 3 (DCIN connector, CF01 connector)"

(2) Specifications of PD25/PD27 power supply

Refer to the section "6.2.2 When Using PD25/PD27 Power Supply Unit" for details on PD25/PD27.

**CAUTION**

- ⚠ Do not apply voltages to the connectors other than voltages indicated in this manual. Failure to observe this could cause the devices to rupture or damage, etc.
- ⚠ Incorrect connections could cause the devices to damage. Connect the cable to the designated connector.
- ⊘ Do not connect or disconnect the connection cables between each unit while the power is ON.

9.2.3 FCU7-DA315-11 / FCU7-DA415-11 / FCU7-DA445-11 (Connections of PD25/PD27 power supply unit)

(1) Connections of PD25/PD27 power supply

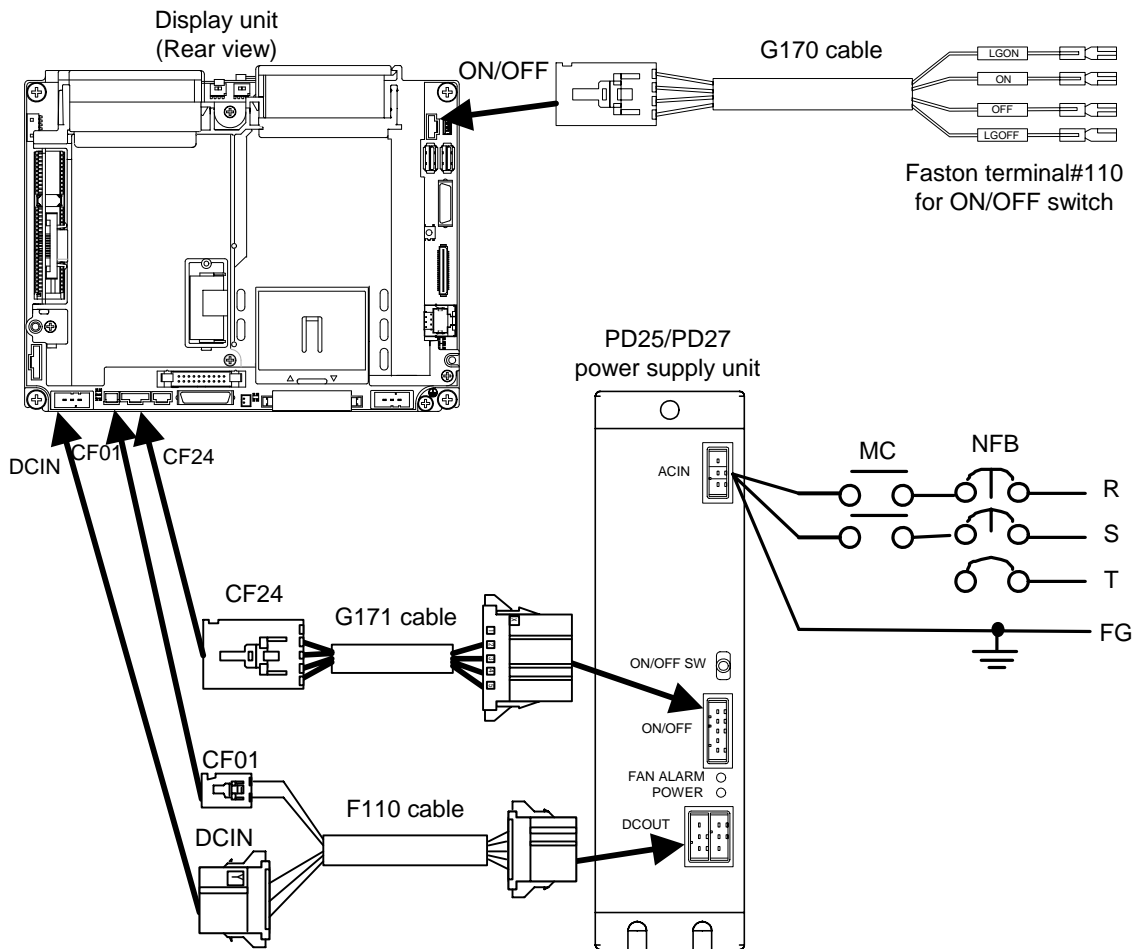

**(Note)** PD25/PD27 cannot be turned ON immediately after it is turned OFF. Wait at least 2 seconds, and then turn the power ON.

**<Related items>**

Cable drawing: "Appendix 2 (F110 cable, G170 cable, G171 cable)"

Connector pin assignment: "Appendix 3 (DCIN connector, CF01 connector, CF24 connector, ON/OFF connector)"

(2) Specifications of PD25/PD27 power supply

Refer to the section "6.2.2 When Using PD25/PD27 Power Supply Unit" for details on PD25/PD27.

**CAUTION**

- ⚠ Do not apply voltages to the connectors other than voltages indicated in this manual. Failure to observe this could cause the devices to rupture or damage, etc.
- ⚠ Incorrect connections could cause the devices to damage. Connect the cable to the designated connector.
- ⊘ Do not connect or disconnect the connection cables between each unit while the power is ON.

### 9.3 Connecting with Operation Panel I/O Unit

Refer to the section "7.3 Connecting with Display Unit".

### 9.4 Connecting with Keyboard Unit

Connect keyboard unit to the connector USB1.  
G290 cable (0.7m) comes with the keyboard unit.

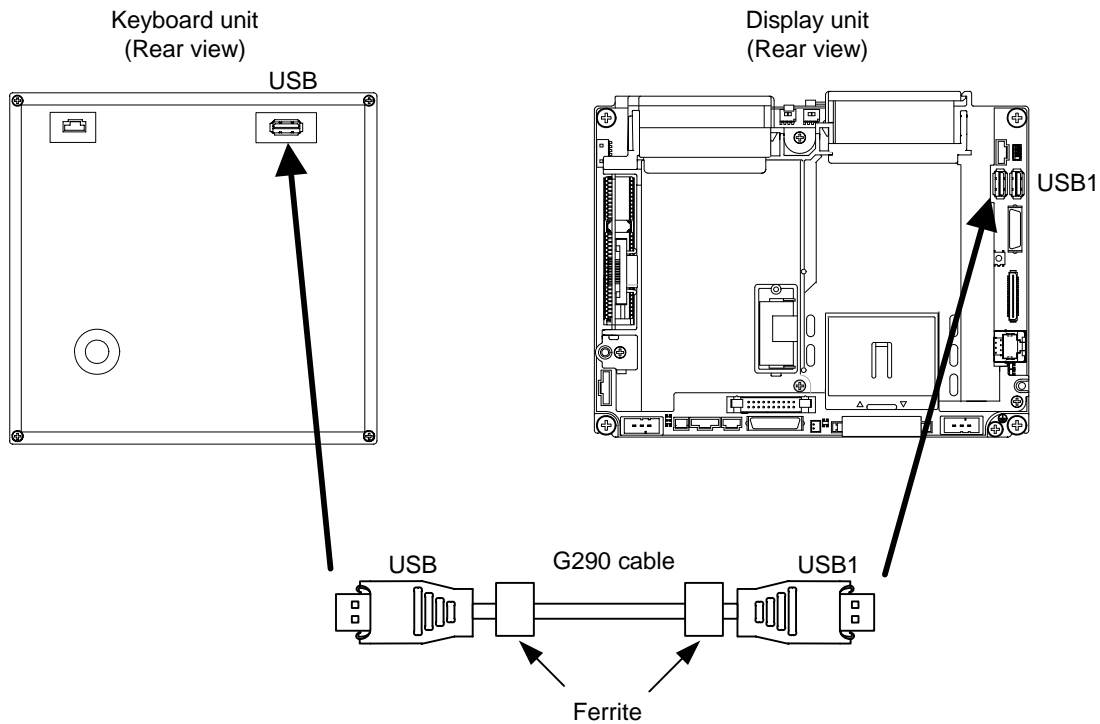

**(Note)** Do not use commercially available USB cable. Failure to observe could result in malfunction.

#### <Related items>

Connector pin assignment: "Appendix 3 (USB connector)"



### CAUTION

- ⚠ Do not apply voltages to the connectors other than voltages indicated in this manual. Failure to observe this could cause the devices to rupture or damage, etc.
- ⚠ Incorrect connections could cause the devices to damage. Connect the cable to the designated connector.
- ⊘ Do not connect or disconnect the connection cables between each unit while the power is ON.

### 9.5 Connecting with Front IC Card I/F Unit

Connect front IC card I/F unit to the connector FRONTOUT.  
G291 cable comes with the front IC card I/F unit.

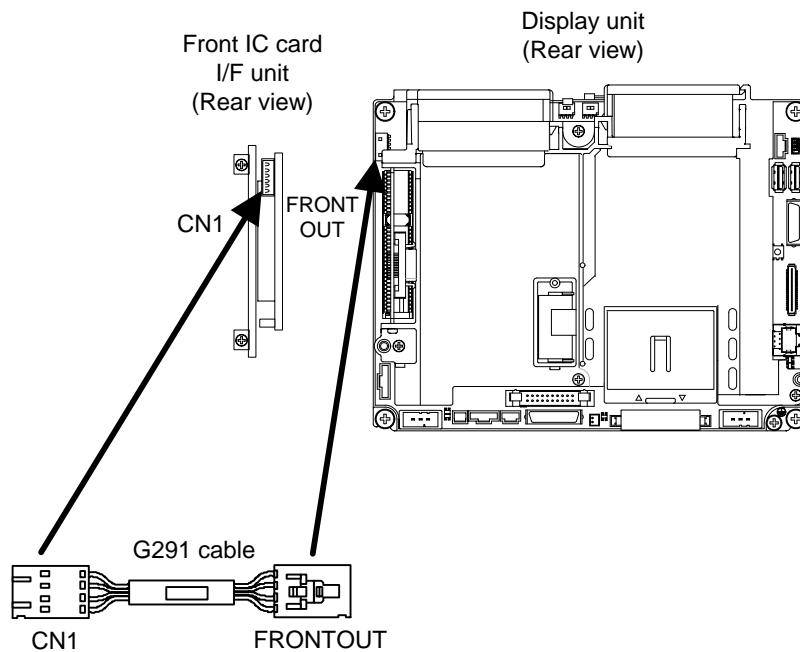

#### <Related items>

Cable drawing: "Appendix 2 (G291 cable)"

Connector pin assignment: "Appendix 3 (FRONTOUT)"

#### **CAUTION**

- ⚠ Do not apply voltages to the connectors other than voltages indicated in this manual. Failure to observe this could cause the devices to rupture or damage, etc.
- ⚠ Incorrect connections could cause the devices to damage. Connect the cable to the designated connector.
- ⊘ Do not connect or disconnect the connection cables between each unit while the power is ON.

## 9. Connections of Display Unit

### 9.6 Connecting with Hard Disk Unit: FCU7-DA315-11 / FCU7-DA415-11 / FCU7-DA445-11

#### 9.6 Connecting with Hard Disk Unit: FCU7-DA315-11 / FCU7-DA415-11 / FCU7-DA445-11

Connect hard disk unit to the connector HDD.

F140 cable comes with the hard disk unit (FCU7-HD001-1).

Hard disk unit can be mounted on the back of the keyboard unit FCU7-KB04□.

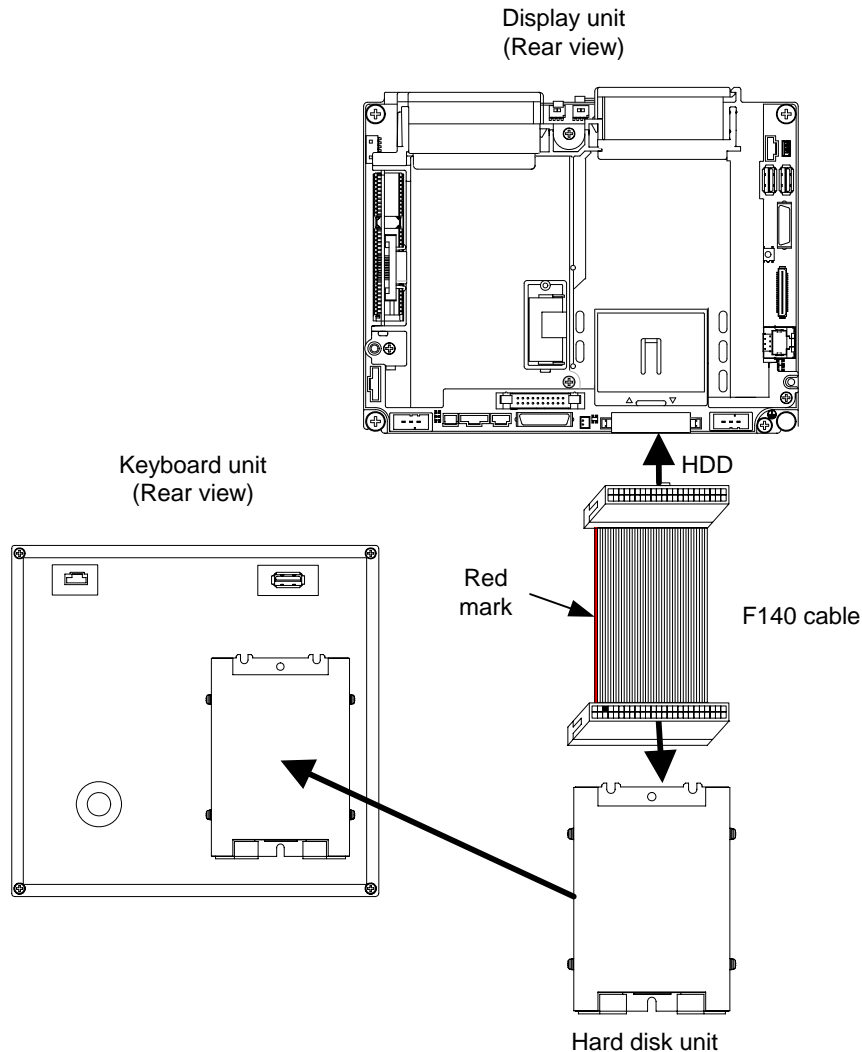

**(Note 1)** When mounting the hard disk unit, face the cable lead-out side straight up and mount within  $\pm 15^\circ$ . (Refer to the section "5.5.1 FCU7-HD001".)

**(Note 2)** Do not turn the power OFF during access to the hard disk. Failure to observe this could cause the units to malfunction. In case of emergency, always perform backups by having your important data duplicated, etc. as MITSUBISHI will not guarantee the broken or lost data. Be sure to inform this matter to the end users.

#### <Related items>

Cable drawing: "Appendix 2 (F140 cable)"

Connector pin assignment: "Appendix 3 (HDD connector)"



### CAUTION

- ⚠ Do not apply voltages to the connectors other than voltages indicated in this manual. Failure to observe this could cause the devices to rupture or damage, etc.
- ⚠ Incorrect connections could cause the devices to damage. Connect the cable to the designated connector.
- ⊘ Do not connect or disconnect the connection cables between each unit while the power is ON.



## 9. Connections of Display Unit

### 9.7 Connecting with Floppy Disk Unit: FCU7-DA315-11 / FCU7-DA415-11 / FCU7-DA445-11

#### 9.7 Connecting with Floppy Disk Unit: FCU7-DA315-11 / FCU7-DA415-11 / FCU7-DA445-11

(1) Connections of floppy disk unit

Connect floppy disk unit to the display unit connector FDD.

F130 cable comes with the floppy disk unit (FCU7-FD221-1).

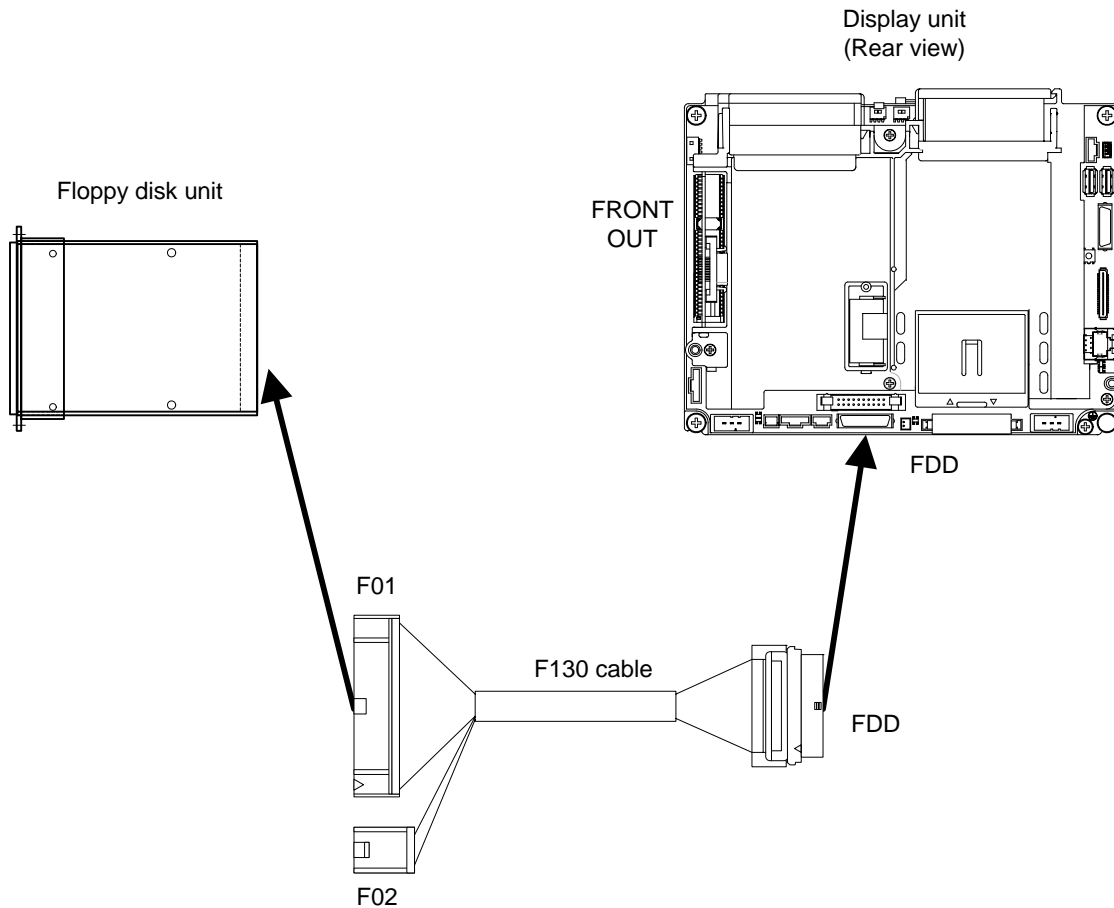

#### <Related items>

Cable drawing: "Appendix 2 (F130 cable)"

Connector pin assignment: "Appendix 3 (FDD connector)"

When connecting F130 cable with the floppy disk unit, arrange so that the PCB side is the bottom and the connector incorrect insertion prevention key is placed facing upward.

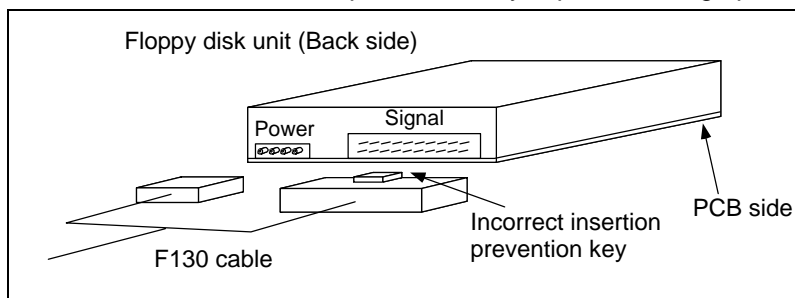

## 9. Connections of Display Unit

### 9.7 Connecting with Floppy Disk Unit: FCU7-DA315-11 / FCU7-DA415-11 / FCU7-DA445-11

#### (2) Floppy disk unit mounting conditions

Mount the floppy disk unit within  $\pm 25^\circ$  in respect to the perpendicular or horizontal position.

The unit cannot be used when the disk slot is tilted (other than perpendicular/horizontal position). ( $\pm 0^\circ$ )

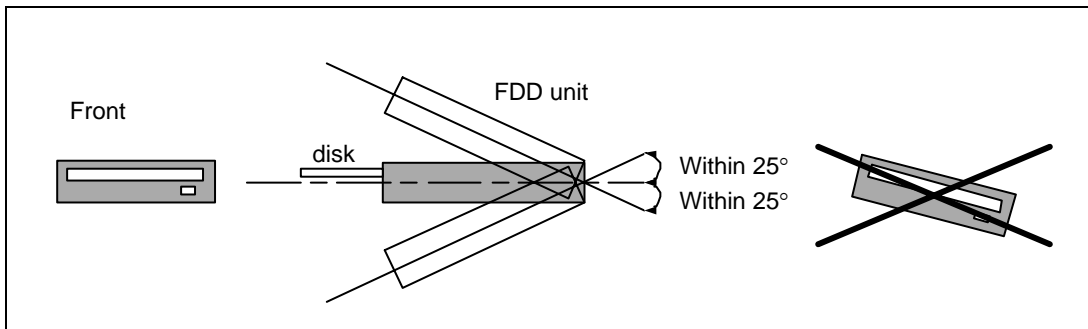



**(Note 1)** Only the mode 2 (720k/1.44M bytes) is available for MITSUBISHI floppy disk drive.

**(Note 2)** MITSUBISHI will not provide performance guarantee and maintenance for commercially available floppy disk drives. Commercially available devices may not be compatible with MITSUBISHI units or suitable for FA environment for temperature- or noise-wise. In the case of using it, careful performance check must be required by the machine tool builder.

**(Note 3)** Do not pull out the floppy disk or turn OFF the power during access to the floppy disk. Failure to observe this could cause the memory contents to be erased. In case of emergency, always perform backups by having your important data duplicated, etc. as MITSUBISHI will not guarantee the broken or lost data. Be sure to inform this matter to the end users.



#### CAUTION

-  Do not apply voltages to the connectors other than voltages indicated in this manual. Failure to observe this could cause the devices to rupture or damage, etc.
-  Incorrect connections could cause the devices to damage. Connect the cable to the designated connector.
-  Do not connect or disconnect the connection cables between each unit while the power is ON.

## 10. Basic Wiring for Servo Drive Unit

### 10.1 Basic Wiring for MDS-D/DH Series

The basic wiring for the MDS-D/DH Series is shown below.

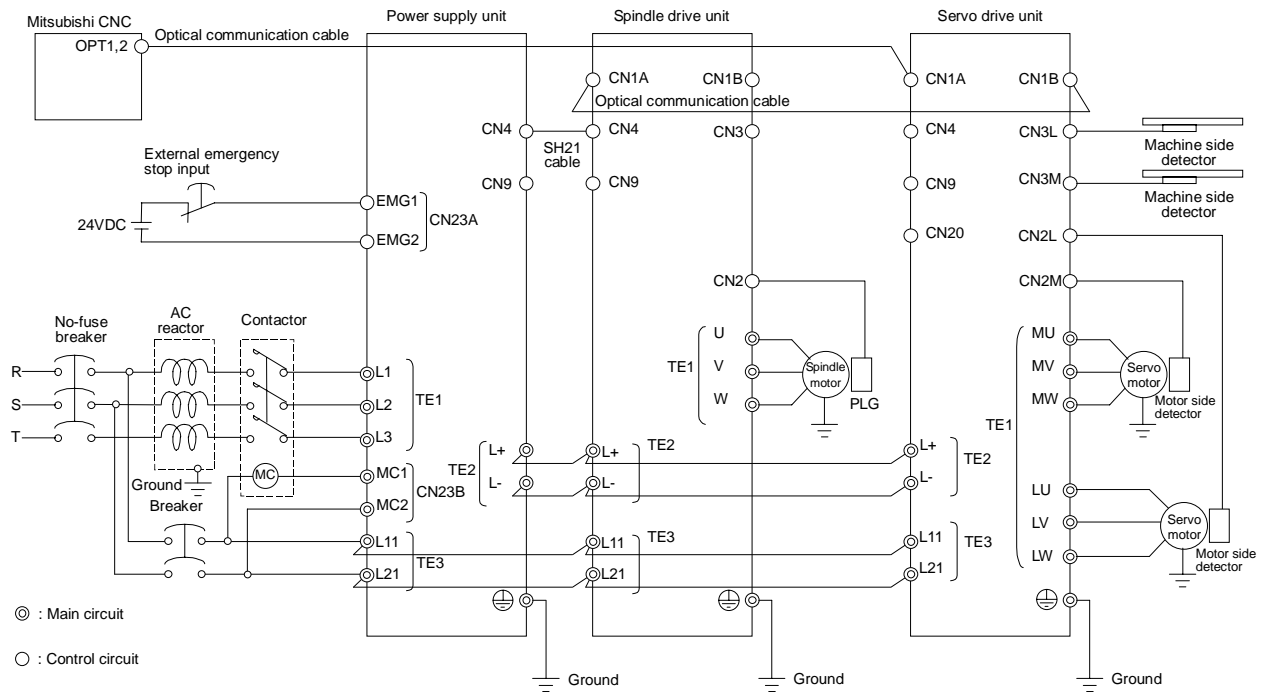

- (Note 1)** The total length of the optical communication cable from the NC must be within 30m and the minimum-bending radius within 80mm.
- (Note 2)** The connection method will differ according to the used motor.
- (Note 3)** Battery for the detector back up is built-in the drive unit. (An external battery is available as an option.)
- (Note 4)** The main circuit (◎) and control circuit (○) are safely separated.

10.2 Basic Wiring for MDS-D-SVJ3/SPJ3 Series

The basic wiring for the MDS-D-SVJ3/SPJ3 Series is shown below.

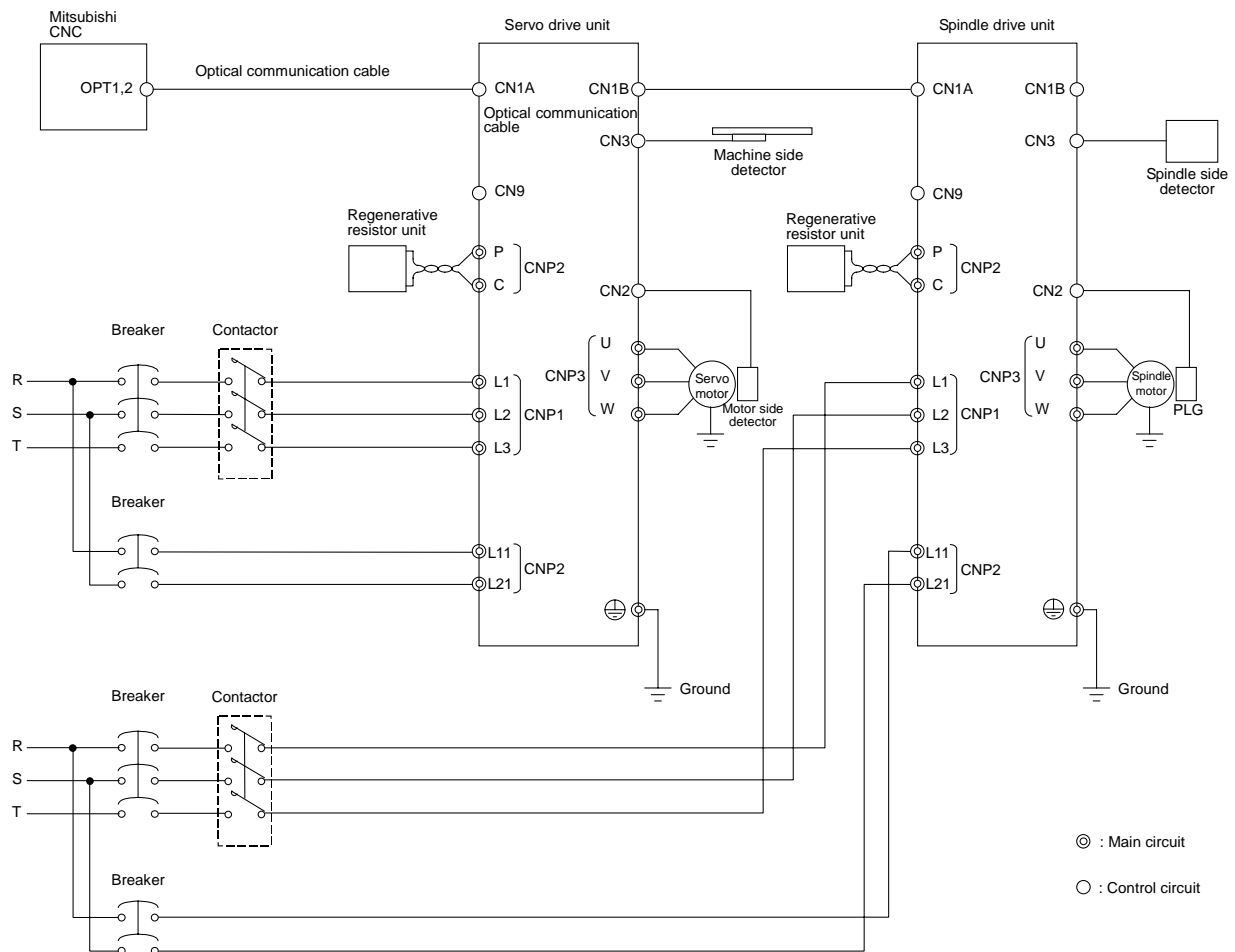

- (Note 1)** The total length of the optical communication cable from the NC must be within 30m and the minimum-bending radius within 80mm.
- (Note 2)** The connection method will differ according to the used motor.
- (Note 3)** Battery for the detector back up is built-in the drive unit. (An external battery is available as an option.)
- (Note 4)** The main circuit (◎) and control circuit (○) are safely separated.

### 11. Turning the Power ON/OFF

To turn the power ON:

turn ON the switch connected to the display unit.

To turn the power OFF:

turn OFF the switch connected to the display unit.

→ Power source of the display and control units is turned OFF after the display unit is shutdown.

(1) When the control unit and the display unit share a power supply

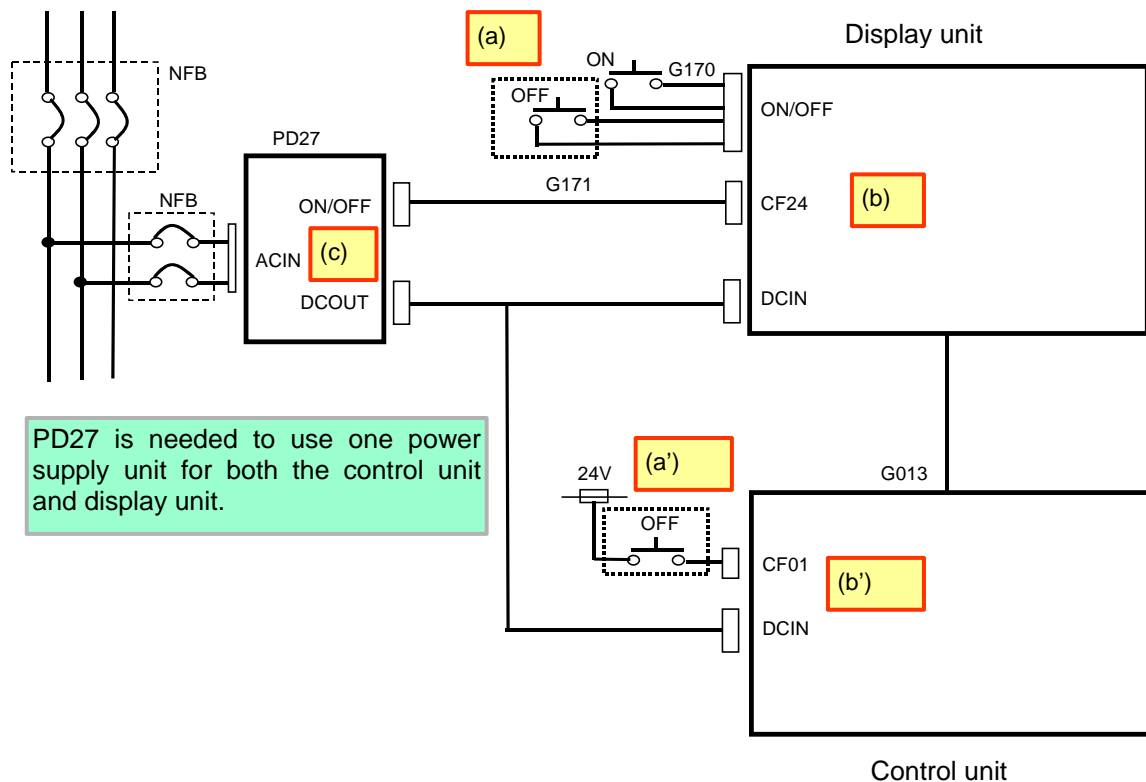

- (a) The switch is turned OFF
- (b) A signal is input from the OFF switch through the G170 cable, which starts a shutdown process.  
After the completion of the shutdown process, the OFF signal is sent to PD27 through G171 cable.
- (c) PD27 stops outputting the voltage.  
Both display and control units are turned OFF.
- (a)'To stop the NC operations at the same time of switching OFF the display unit (in order to keep the axis position during the shutdown process, for example), send the same OFF signal to the control unit using the switch of 2a contact.
- (b)'The OFF switch inputs a signal to CF01, which starts a NC termination process.  
(including a termination notification to the servo drive unit)

## 11. Turning the Power ON/OFF

(2) When the control unit and the display unit use each different power supply

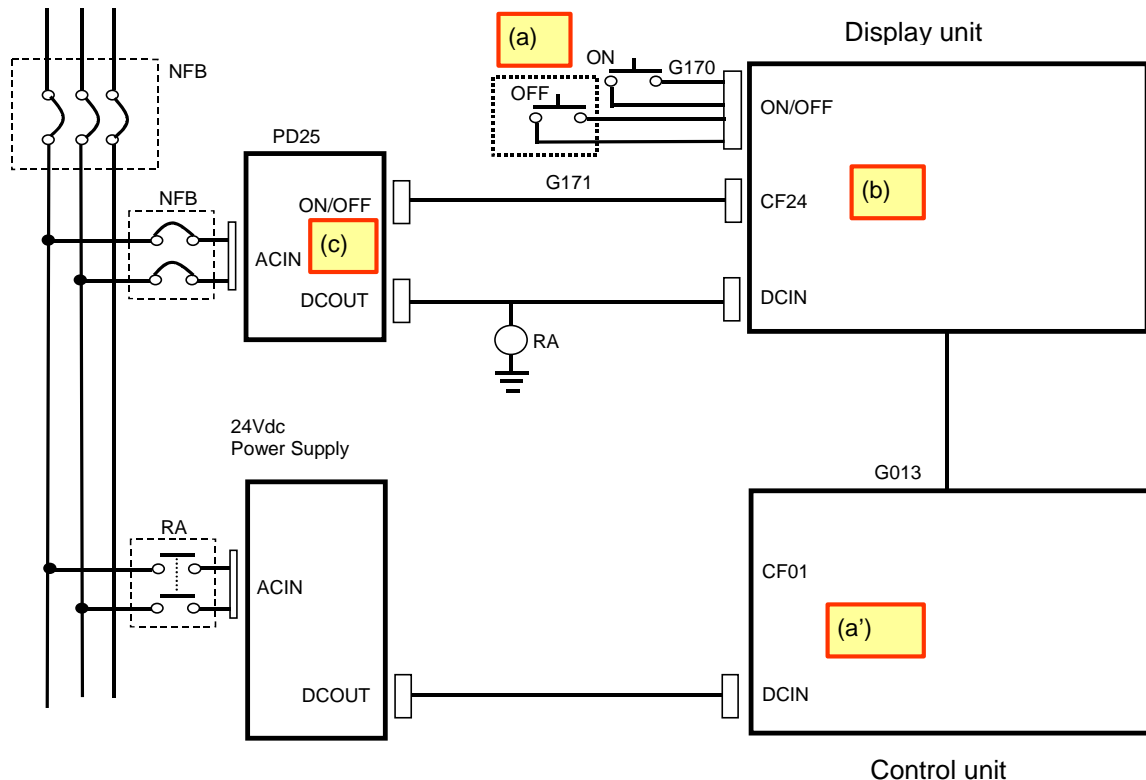

- (a) The switch is turned OFF
- (b) A signal is input from the OFF switch through the G170 cable, which starts a shutdown process. After the completion of the shutdown process, the OFF signal is sent to PD25 through G171 cable.
- (c) PD25 stops outputting the voltage. Relays operate to turn OFF the other power source. Both display and control units are turned OFF.
- (a)' To stop the NC operations at the same time of switching OFF the display unit (in order to keep the axis position during the shutdown process, for example), the control unit also needs to be turned OFF.

## Appendix 1. EMC Installation Guidelines

Refer to the "EMC Installation Guidelines BNP-B8582-45" for details related to the drive section (servo/spindle drive unit).

### 1.1 Introduction

EMC Directives became mandatory as of January 1, 1996. The subject products must have a CE mark attached indicating that the product complies with the Directives.

As the NC unit is a component designed to control machine tools, it is believed that it is not a direct EMC Directives subject. However, we would like to introduce the following measure plans to back up EMC Directives compliance of the machine tool as the NC unit is a major component of the machine tools.

- (1) Methods of installation in control/operation panel
- (2) Methods of wiring cables to outside of panel
- (3) Introduction of members for measures

Mitsubishi is carrying out tests to confirm the compliance to the EMC Directives under the environment described in this manual. However, the level of the noise will differ according to the equipment type and layout, control panel structure and wiring lead-in, etc. Thus, we ask that the final noise level be confirmed by the machine manufacturer.

### 1.2 EMC Directives

The EMC Directives largely regulate the following two items.

- Emission Capacity to prevent output of obstructive noise that adversely affects external devices.
- Immunity Capacity to not malfunction due to obstructive noise from external source.

The details of each level are classified in the table below.

It is assumed that the Standards and test details required for a machine tool are the same as these.

Class	Name	Details	EN Standards	
Emission				
	Radiated noise	Restriction of electromagnetic noise radiated through the air	EN61000-6-4 (General industrial machine)	EN55011 (CLASS: A)
	Conductive noise	Restriction of electromagnetic noise discharged from power supply line	EN61800-3 (Motor control unit)	
Immunity				
	Static electricity electrical discharge	(Example) Regulation of withstand level of static electricity electrical discharge accumulated in human body	EN61000-6-2 (General industrial machine) EN61800-3 (Motor control unit)	EN61000-4-2
	Radiation immunity	(Example) Simulation of immunity from digital wireless telephones		EN61000-4-3
	Burst immunity	(Example) Regulation of withstand level of noise from relay or plug and play		EN61000-4-4
	Conductive immunity	(Example) Regulation of withstand level of noise flowed from power supply wires, etc.		EN61000-4-6
	Power supply frequency magnetic field	(Example) Regulation of electromagnetic noise of 50/60Hz power supply frequency		EN61000-4-8
	Power supply dip (fluctuation)	(Example) Regulation of power voltage drop withstand level		EN61000-4-11
	Surge	(Example) Regulation of withstand level of noise caused by lightning		EN61000-4-5

### 1.3 EMC Measures

The main items relating to EMC measures include the following.

- (1) Store the device in a sealed metal panel.
- (2) Ground all conductors that are floating electrically. Decrease the impedance.
- (3) Increase the distance between the drive line and signal wire.
- (4) Shield the cables wired outside of the panel.
- (5) Install a noise filter.

Take care to the following items to suppress the noise radiated outside of the panel.

- (1) Accurately ground the devices.
- (2) Use shielded cables.
- (3) Increase the electrical seal of the panel. Reduce the gaps and holes.

### 1.4 Panel Structure

The design of the panel is a very important factor for the EMC measures, so take the following measures into consideration.

#### 1.4.1 Measures for Control Panel Body

- (1) Use metal for all members configuring the panel.
- (2) When joining the metal plate, treat the welded or contacting sections so that the impedance is reduced, and then fix with screws.

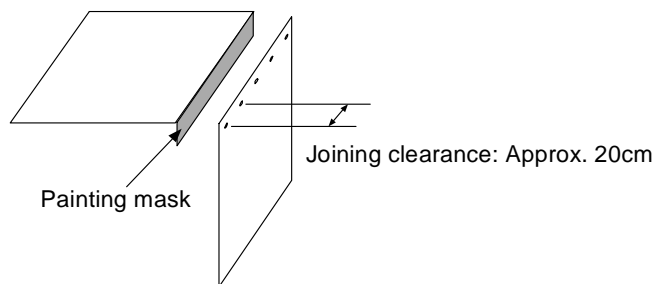

- (3) Note that if the plate warps due to the screw fixing, etc. By creating a clearance, noise could leak from that place.
- (4) Plate (nickel tin) the metal plate surface at the grounding plate, and connect the connections with a low impedance.
- (5) If there is a large opening, such as ventilation holes, make sure to close the hole.

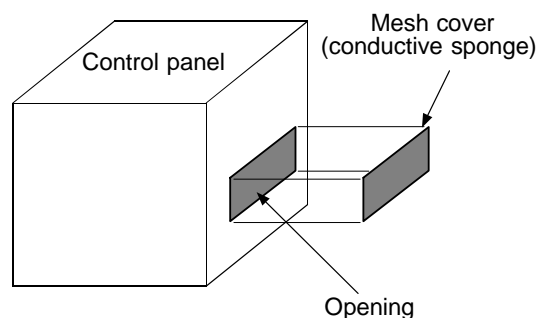

**(Note 1)** Using screws to fix the plates that have been painted is the same as an insulated state. Peel the paint and fix the screws.



1.4.2 Measures for Door

- (1) Use metal for all materials configuring the panel.
- (2) When joining the door, use a gasket to lower the impedance of the contacting sections, or use a structure with a large contact area as shown below.
- (3) The EMI gasket or conductive packing must contact the metal surface uniformly and at the correct position.

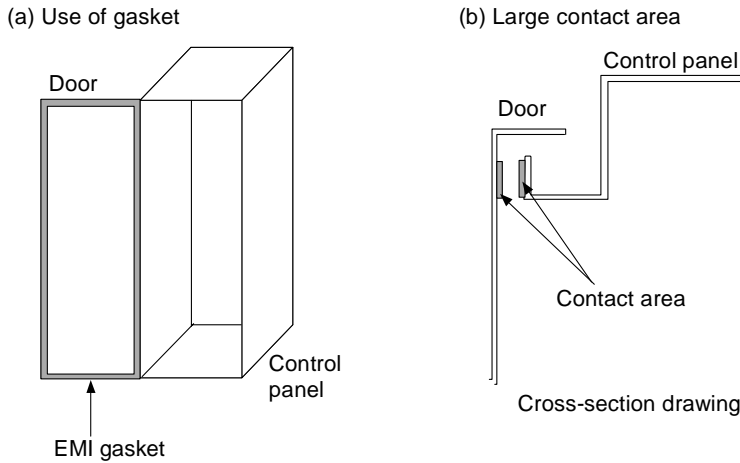

**(Note 1)** When not using a gasket, ground the control panel grounding with a grounding wire to lower the door's impedance.

**(Note 2)** Using screws to fix the plates that have been painted (attachment of packing) is the same as an insulated state. Peel the paint and fix the screws.

1.4.3 Measures for Power Supply

- (1) Shield the power supply section and insert a filter to prevent the noise from flowing in or out. Selection of the noise filter capacity will differ according to the drive unit and devices being used. Refer to the "EMC Installation Guidelines" (BNP-B8582-45).

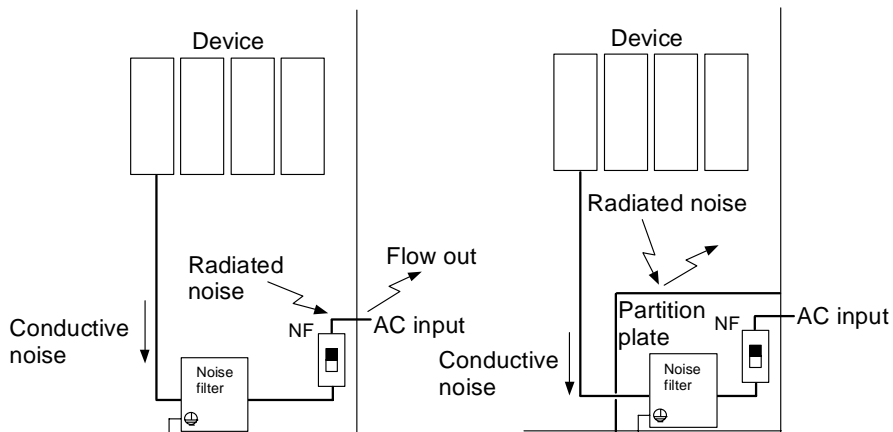

**(Note 1)** The conductive noise can be suppressed by inserting a noise filter, but the radiated noise will flow out.

**(Note 2)** The conductive and radiated noise can both be suppressed by adding a partition plate to the noise filter.

### 1.5 Measures for Wiring in Panel

Cables act as antennas to propagate unnecessary noise, and thus must be appropriately shielded and treated. The following measures must be sufficiently considered for the cables (SH21/G013/F012/FCUA-R211) that carry out high-speed communication.

#### 1.5.1 Precautions for Wiring in Panel

- (1) If the cables are led unnecessary in the panel, they will pick up noise. Pay attention to the device layout and wire length so that the wiring length is as short as possible.

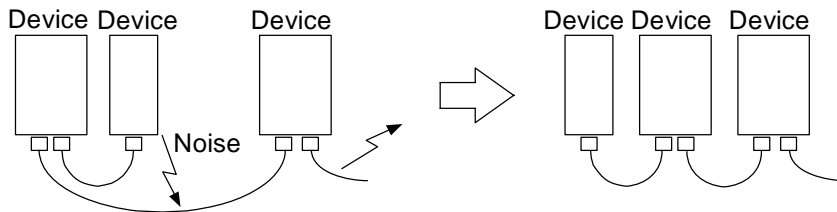

- (2) Always connect the grounding wire to the FG terminal indicated on the device.
- (3) Keep the distance between the drive line and detector cable to the drive section motor as far apart as possible when wiring.
- (4) Do not lead the power supply wire around the panel without using a filter.

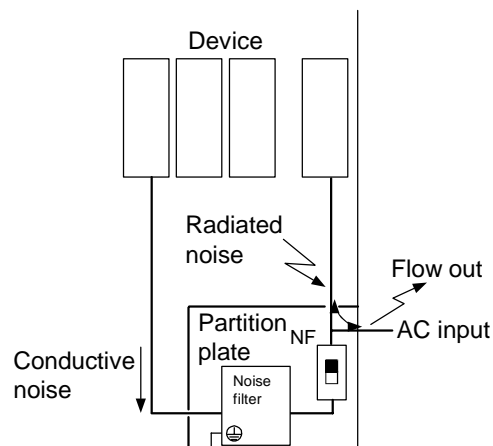

1.5.2 Shield Treatment of Cables

Use shielded cables for the cables wired outside the panel.

Use a shield clamp within 10cm of the lead-out port from the panel. (Refer to "Appendix 1.6.1 Shield clamp fitting".)

(1) DC power supply cable [F110/F070 cable]

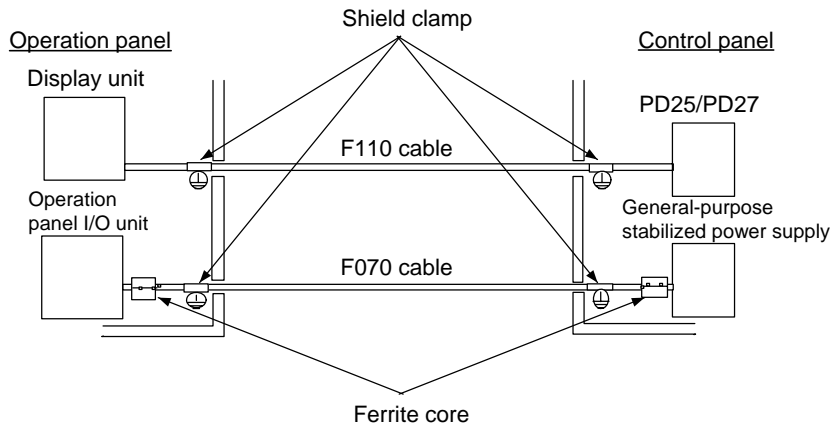

- Use a shield clamp within 10cm from the panel's inlet/outlet.
  - Install a ferrite core on both ends of the connected units.
  - Always install a ferrite core on the general-purpose stabilized power supply. (Refer to "Appendix 1.6.2 Ferrite core".)
- The ferrite core may not be required depending on the selected power supply.

(2) Remote I/O cable [FCUA-R211 cable]

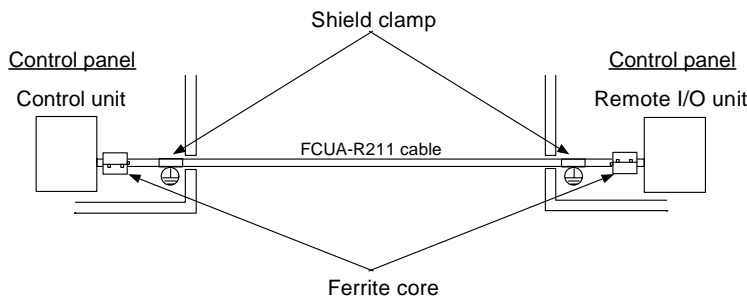

- Use a shield clamp within 10cm from the panel's inlet/outlet.
- Install a ferrite core on both ends of the connected units.

(3) Servo communication cable [SH21 cable]

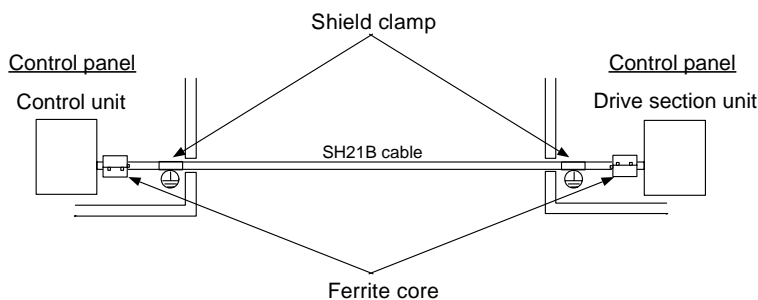

- Use a shield clamp within 10cm from the panel's inlet/outlet.
- Install a ferrite core on both ends of the connected units.

### 1.6 EMC Countermeasure Parts

#### 1.6.1 Shield Clamp Fitting

The effect can be improved by directly connecting the cable's shield sheath to the grounding plate as shown below.

Install the grounding plate near the outlet (within 10cm) of each panel, and press against the grounding plate with the clamp fitting.

If the cables are thin, several can be bundled and clamped together. To provide sufficient frame ground, install the grounding plate directly on the cabinet or connect with a grounding wire.

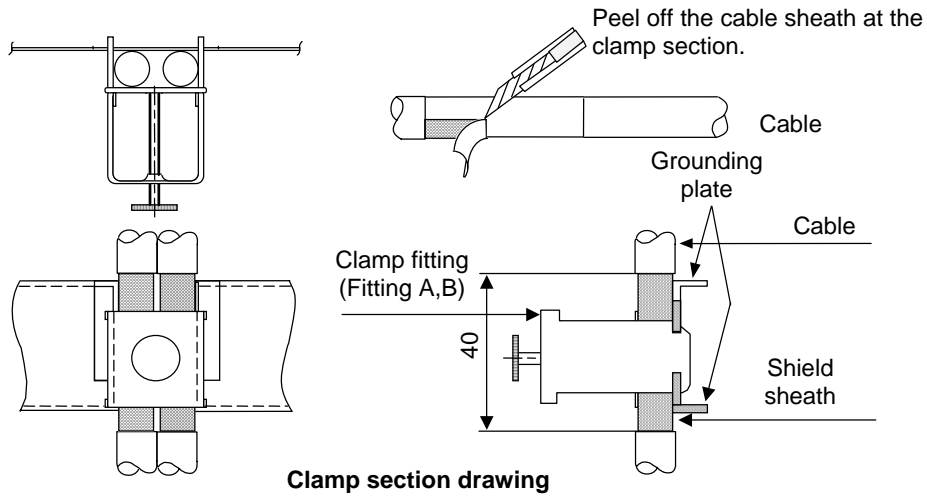

#### 1.6.2 Ferrite Core

The ferrite core is mounted integrally with the plastic case.

This can be installed with one touch without cutting the interface cable or power supply cable.

This ferrite core is effective against common mode noise, allowing measures against noise without affecting the quality of the signal.

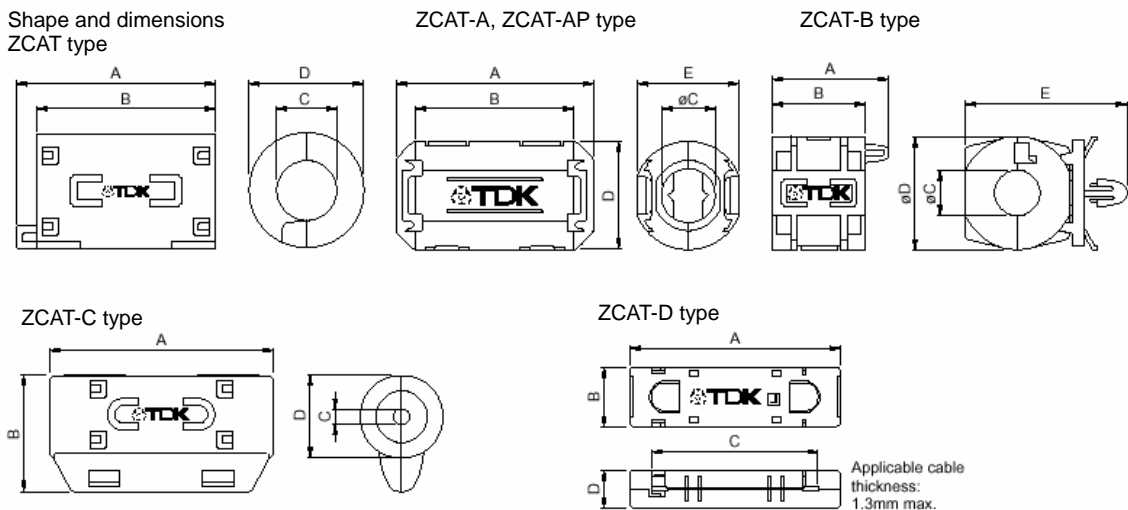

## Recommended ferrite core: TDK ZCAT Series

Unit : mm

Part Name	A	B	øC	øD	E	Applicable cable outer diameter	Mass (g)
ZCAT1518-0730-M(-BK)*1	22±1	18±1	7±1	15±1	-	7max.	6
ZCAT1518-0730(BK)*2	22±1	18±1	7±1	15±1	-	7max.	6
ZCAT2017-0930-M(-BK)	21±1	17±1	9±1	20±1	-	9max.	11
ZCAT2032-0930-M(-BK)*1	36±1	32±1	9±1	19.5±1	-	9max.	22
ZCAT2032-0930(-BK)*2	36±1	32±1	9±1	19.5±1	-	9max.	22
ZCAT2132-1130-M(-BK)*1	36±1	32±1	11±1	20.5±1	-	11max.	22
ZCAT2132-1130(-BK)*2	36±1	32±1	11±1	20.5±1	-	11max.	22
ZCAT3035-1330-M(-BK)*1	39±1	34±1	13±1	30±1	-	13max.	63
ZCAT3035-1330(-BK)*2	39±1	34±1	13±1	30±1	-	13max.	63
ZCAT1525-0430AP-M(-BK)	25±1	20±1	4±1	15±1	11.5±1	2.5 to 4 (USB)	7
ZCAT1325-0530A-M(-BK)*1	25±1	20±1	5±1	12.8±1	11.2±1	3 to 5 (USB)	7
ZCAT1325-0530A(-BK)	25±1	20±1	5±1	12.8±1	11.2±1	3 to 5 (USB)	7
ZCAT1730-0730A-M(-BK)	30±1	23±1	7±1	16.5±1	15±1	4 to 7 (USB)	12
ZCAT2035-0930A-M(-BK)*1	35±1	28±1	9±1	19.5±1	17.4±1	6 to 9	22
ZCAT2035-0930A(-BK)	35±1	28±1	9±1	19.5±1	17.4±1	6 to 9	22
ZCAT2235-1030A-M(-BK)	35±1	28±1	10±1	21.5±1	20±1	8 to 10	27
ZCAT2436-1330A-M(-BK)	36±1	29±1	13±1	23.5±1	22±1	10 to 13	29
ZCAT2017-0930B-M(-BK)	21±1	17±1	9±1	20±1	28.5±1	9max.	12
ZCAT2749-0430C-M(-BK)	49±1	27±1	4.5±1	19.5±1	-	4.5max.	26
ZCAT4625-3430D(-BK)	45.5±1	24.5±1	34±1	12±1	-	26 For core flat cable	32
ZCAT4625-3430DT(-BK)*3	45.5±1	24.5±1	34±1	13±1	-	26 For core flat cable	32
ZCAT6819-5230D(-BK)	67.5±1	18.5±1	52±1	16±1	-	40 For core flat cable	58
ZCAT6819-5230DT(-BK)*3	67.5±1	18.5±1	52±1	17±1	-	40 For core flat cable	58

\*1 The M stamp is attached.

\*2 A fixing band is attached at shipment.

\*3 The core is fixed with double-sided tape. (The tape is enclosed with the part.)

- ZCAT-B type : Cabinet fixing type installation hole ø4.8 to 4.9mm, plate thickness 0.5 to 2mm
- ZCAT-AP, ZCAT-C type: Structure that prevents easy opening after case is closed.

1.6.3 Surge Absorber

Make sure that the surge does not directly enter the AC line of the general-purpose stabilized power supply (user-prepared) supplying power to the control unit and DIO. Select the following product or equivalent for the surge absorber.

Refer to the manufacturer catalog for detailed characteristics, outline and connection methods of the surge absorber.

- (1) Part name : RAV-781BYZ-2  
 Manufacturer : OKAYA ELECTRIC INDUSTRIES

Circuit voltage 50/60Hz Vrms	Max. tolerable circuit voltage	Clamp voltage V±10%	Surge withstand level 8/20µs	Surge electrical discharge start voltage 1.2/50µs	Static capacity	Working temperature range
250V 3φ	300V	783V	2500A	20kV	75pF	-20 ~ +70°C

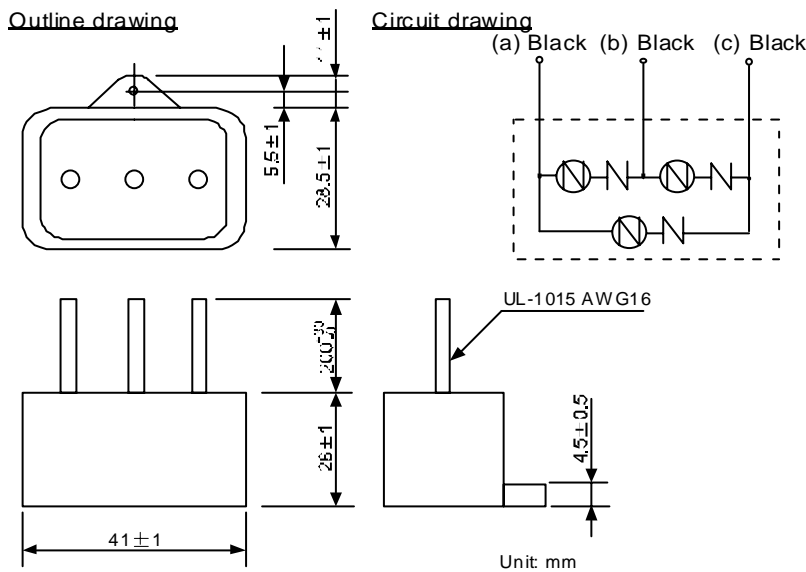

- (2) Part name : RAV-781BXZ-4  
 Manufacturer : OKAYA ELECTRIC INDUSTRIES

Circuit voltage 50/60Hz Vrms	Max. tolerable circuit voltage	Clamp voltage V±10%	Surge withstand level 8/20µs	Surge electrical discharge start voltage 1.2/50µs	Static capacity	Working temperature range
250V 3φ	300V	700V	2500A	2kV	75pF	-20 ~ +70°C

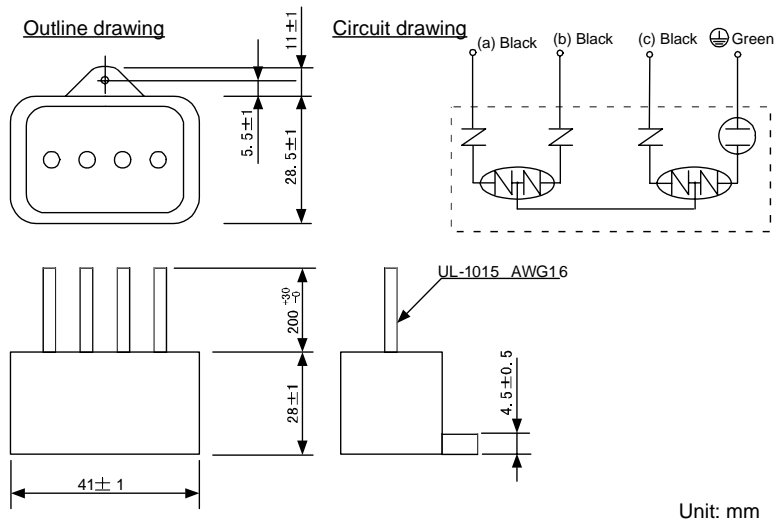

## Example of surge absorber installation

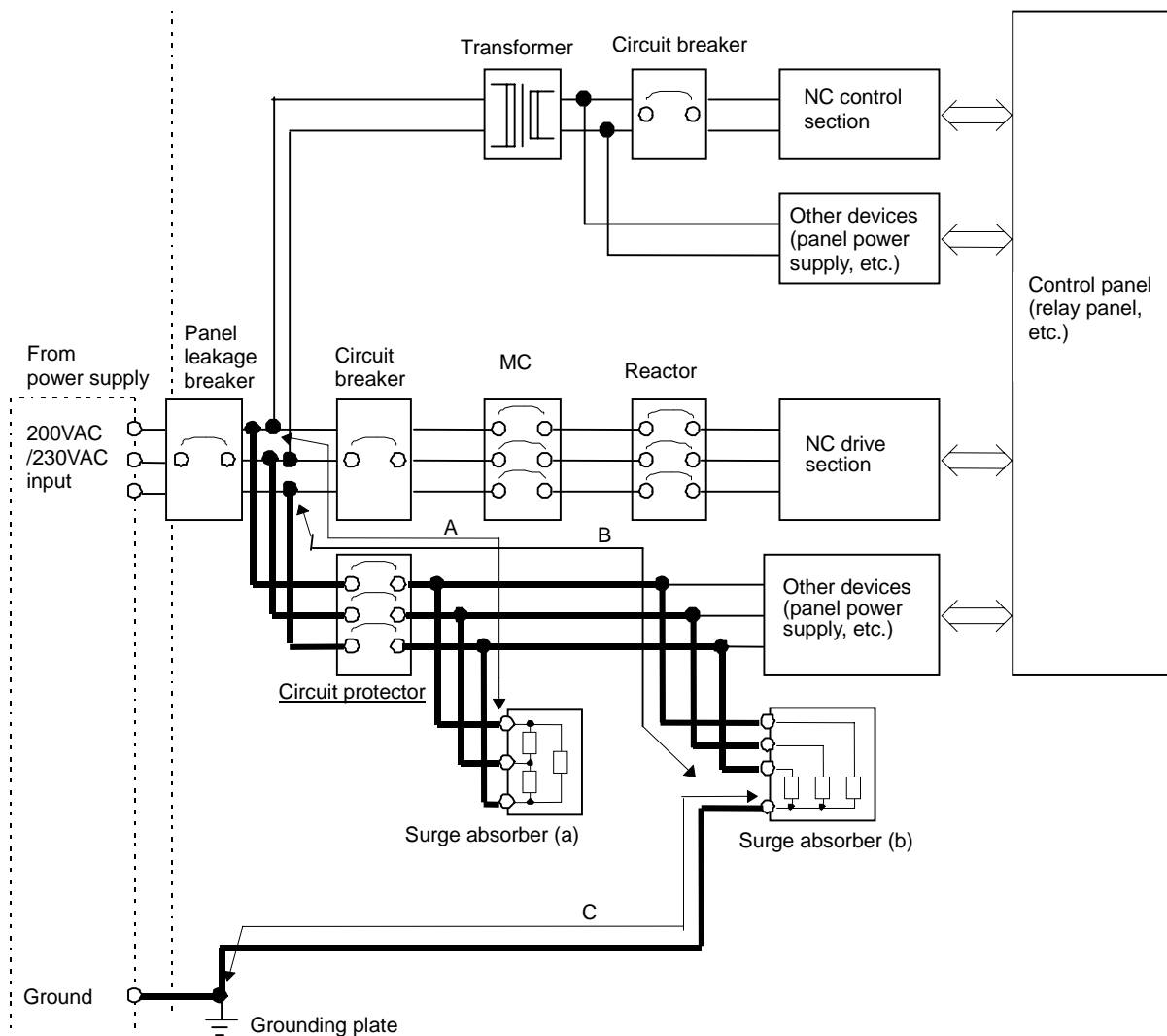
**Example of surge absorber installation****Precautions**

- (1) Use a thick wire that is as short as possible to increase the lightning surge absorbing effect as shown with the bold lines in the installation example above.
  - Wire material : Diameter 2mm<sup>2</sup> or more
  - Wire length      Length of wire connected to surge absorber (a) : A is 2m or less
  - Length of wire connected to surge absorber (b) : B is 2m or less
  - Length of wire connected to surge absorber (b) : C is 2m or less
- (2) When carrying out the insulation withstand voltage test on the power supply line, the surge absorber will activate by the applied voltage, so always remove surge absorber (b).
- (3) If a surge exceeding the tolerance is applied on the surge absorber, a short-circuit fault will occur. Thus, always insert a circuit protector to protect the power supply line. Normally, current is not passed to the surge absorber (a) and (b), so the circuit protector can be used for the other devices.

**1.6.4 Selection of Stabilized Power Supply**

Consider the following characteristics when selecting the stabilized power supply (prepared by machine manufacturer).

Use a power supply that complies with CE Marking or that follows the safety standards given below.

**Stabilized power supply selection items**

Item		Standard setting	Remarks
Output	Voltage fluctuation	±5%	±5% or less of 24VDC output
	Ripple noise	120mV (max.)	
	Spike noise	500mV (max.)	
Output current		-	Refer to the maximum current consumption of the unit in use and calculate.
Output holding time		20ms (min.)	Instantaneous power failure time (AC side)

**Standards**

Safety Standards : UL1950, CSA C22.2 No. 234 approved, IEC950 compliant

Noise Terminal Voltage : FCC Class A, VCCI-Class A

High Harmonics Current Restrictions : IEC61000-3-2



## Appendix 2. Cable

## List of cable type

Cable type	Application	Max. length	Standard cable length (m)	Remarks
G013	I/O interface	20m	1, 2, 3, 5, 7, 10, 15, 20	Connect between control unit and operation panel I/O unit.
G014	I/O interface	20m	1, 2, 3, 5, 7, 10, 15	Connect between control unit and operation panel I/O unit. (Unit - Panel)
G015	I/O interface	20m	1, 2, 3, 5, 7, 10, 15	Connect between control unit and operation panel I/O unit (Unit - Panel)
F020	Manual pulse generator: 1ch	50m	0.5, 1, 2, 3, 5, 7, 10, 20	Connect to operation panel I/O unit.
F021	Manual pulse generator: 2ch	50m	1, 2	12V power supply type can be used.
F022	Manual pulse generator: 3ch	50m	1, 2	
G020	Manual pulse generator: 1ch	20m	2	
G021	Manual pulse generator: 2ch	20m	2	5V power supply type can be used.
G022	Manual pulse generator: 3ch	20m	2	
G023	Manual pulse generator: 1ch	20m (*)	1, 2, 3, 5, 8, 10, 15, 20	
G024	Manual pulse generator: 2ch	20m (*)	1, 2, 3, 5, 8, 10, 15, 20	Connect to control unit. 5V power supply type can be used.
FCUA-R030	Skip input	20m	3, 7	Connect to control unit.
FCUA-R031	Analog input/output	20m	3, 7	Connect to remote I/O unit.
G031	RS-232C : 1ch	15m (*)	0.5, 1, 2, 3, 5, 7, 10, 15	Connect to display unit.
G032	RS-232C : 2ch	15m (*)	0.5, 1, 2, 3, 5, 7, 10, 15	Connect to display unit.
F034	RS-232C: 1ch	15m (*)	0.5, 1, 2, 3, 5, 7, 10, 15	Connect to control unit.
F035	RS-232C: 2ch	15m (*)	0.5, 1, 2, 3, 5, 7, 10, 15	Connect to control unit.
FCUA-R041	Manual pulse generator: 1ch	20m	3, 5, 7, 10, 15, 20	Connect to remote I/O unit. 12V power supply type can be used.
FCUA-R042	Manual pulse generator: 2ch	20m	3	
FCUA-R050	Encoder input	50m	5	Straight type connector
FCUA-R054	Encoder input	50m	3, 5, 10, 15, 20	Right angle type connector
F070	24VDC input	30m	0.5, 1.5, 3, 5, 7, 10, 15, 20	
F110	24VDC input, power OFF detection	15m	0.5, 1.5, 3, 5, 8, 10, 15	
F120	Emergency stop	30m	0.5, 1.5, 3, 5, 7, 10, 15, 20	
G123	Emergency stop terminator	-	-	
F130	FDD	1m	1	
F140	HDD	0.5m	0.5	Standard: 0.5m

## Appendix 2. Cable

Cable type	Application	Max. length	Standard cable length (m)	Remarks
G170	ON/OFF switch	15m	0.35, 0.5, 1, 1.5, 2, 3, 5, 10, 15	Connect between ON/OFF switch and display unit.
G171	ON/OFF switch	15m	0.5, 1, 3, 5, 7, 10, 15	Connect between display unit and PD25/PD27 power supply unit.
F170	ON/OFF switch	15m	-	For PD25
FCUA-R211	Remote I/O	30m (*)	0.3, 1, 2, 5, 7, 10, 15, 20, 30	Connect to remote I/O unit. With FG terminal
G290	USB cable	1m	0.7	Standard: 0.7m, enclosed with keyboard unit.
G291	Front IC card I/F	0.1m	0.1m	Connect between display unit and front IC card I/F unit.
G300	LAN cross cable	10m	1, 3, 5, 7, 10	Connect between display unit and control unit. Shielded cable should be used when 1m or longer.
G301	LAN straight cable	1m	1	Connect between display unit and operation panel I/O unit. Shielded cable should be used when 1m or longer.
R300	DI/DO	50m	3	Single-side connector not available
R301	DI/DO	50m	1, 2, 3, 5	Double-side connector available
G310	NC reset	15m	0.1	Standard: 0.1m
G380	Optical servo communication	20m	5, 10, 13, 15, 20	PCF type with outer sheath, for panel external wiring
G395	Optical servo communication	10m	1, 2, 3, 5, 10	POF type with outer sheath, for panel external wiring
G396	Optical servo communication	10m	0.3, 0.5, 1, 2, 3, 5, 10	POF type without outer sheath, for panel internal wiring
G430	Handy terminal	10m	3, 5, 10	Use for connecting a handy terminal. (Install on panel)
SH21	Servo communication	30m	0.2, 0.3, 0.5, 1, 3, 5, 10, 15	Connect to peripheral servo drive unit.
SH41	Remote I/O	1m (*)	0.3, 0.5, 0.7	Use for bridging units in same panel. Use FCUA-R211 for lengths longer than 1m.
E-TM	OPI connector terminator	-	-	
R-TM	Remote I/O interface terminator	-	-	

**(Note 1)** Lengths indicated with an asterisk (\*) in the Max. length column indicate the maximum cable length when connecting from the control unit via other unit.

**(Note 2)** Symbols for writing cable drawings

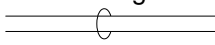
(1)  indicates twisted pair.

(2)  indicates the shield sheath.

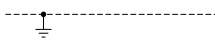
(3)  indicates shield clamping to the grounding plate.

(4) In the cable drawings, the partner of the twisted pair cable is given a priority, so the pin No. of the connectors at both ends are not necessary in number of order.

(5) Equivalent parts can be used for the connector, contact and wire material.

2.1 G014 Cable

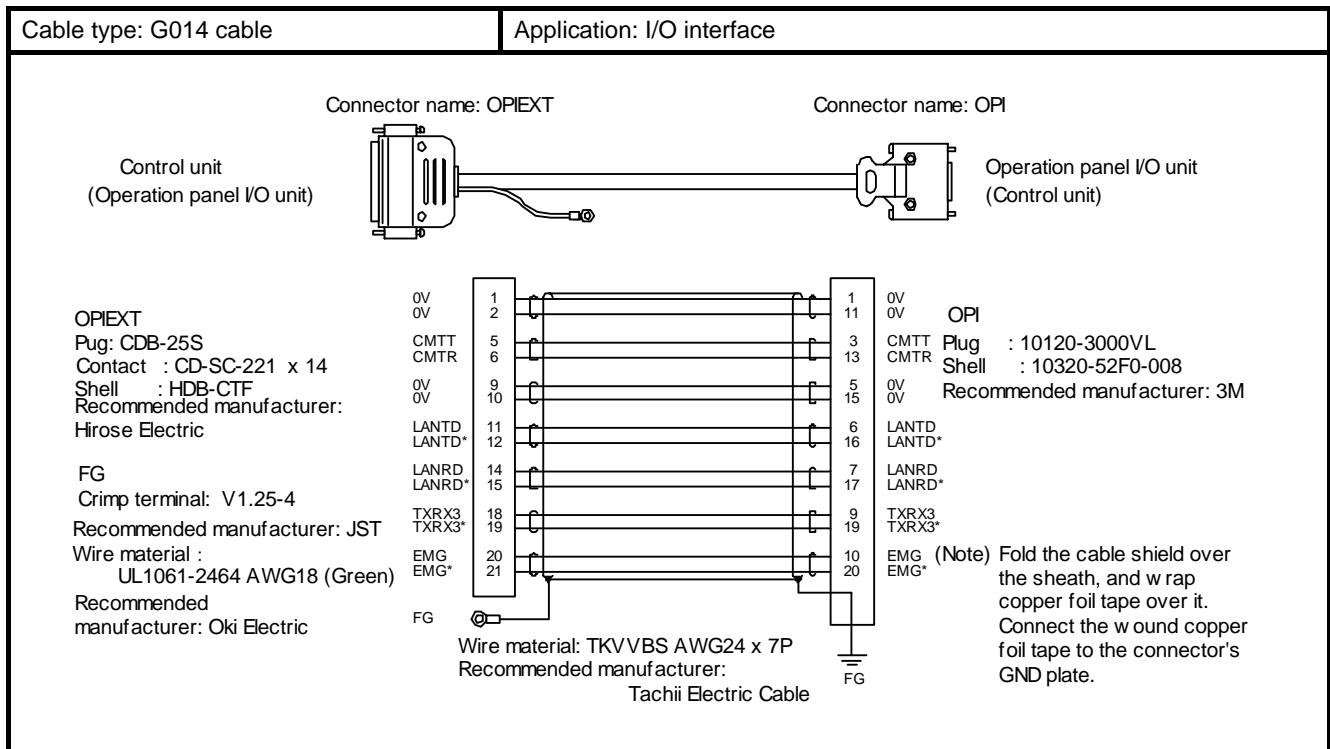

2.2 G015 Cable

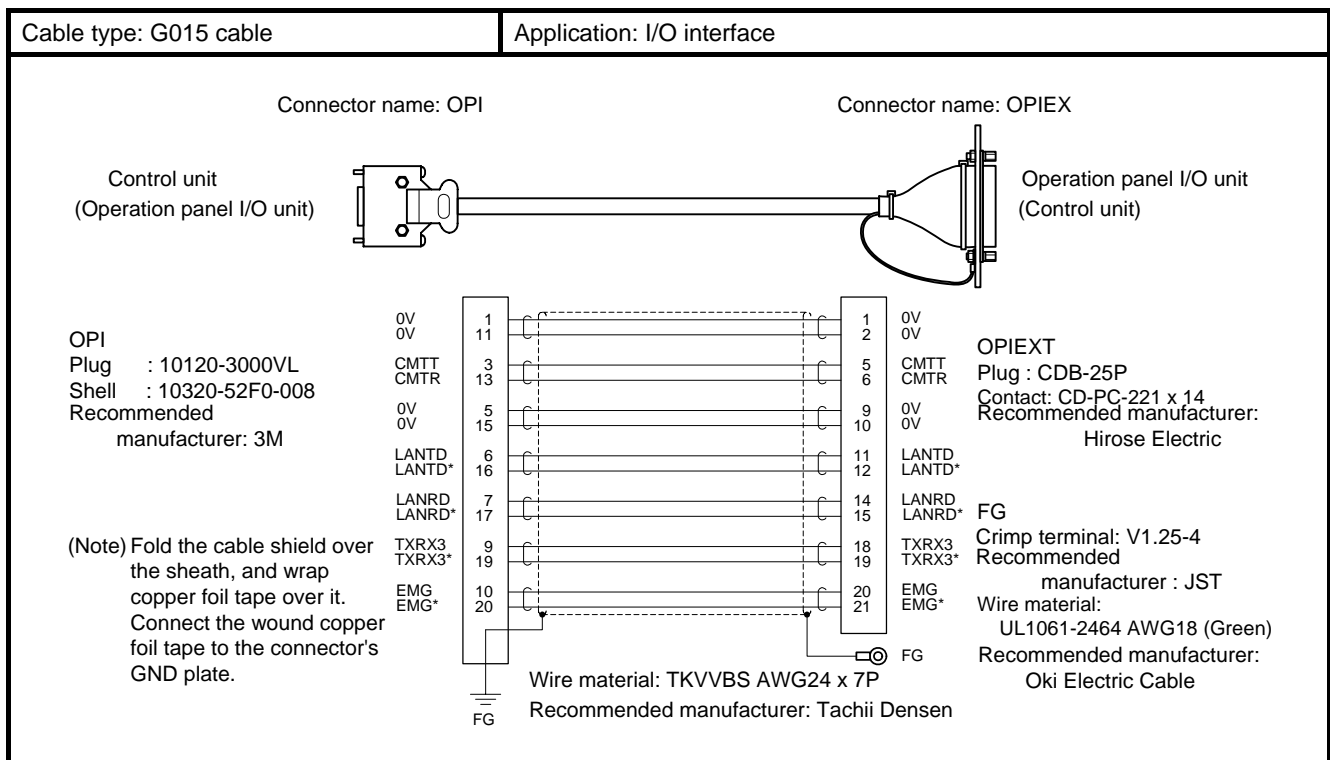

2.3 F020/F021/F022 Cable

Cable type: F020/021/022 cable	Application: Manual pulse generator (12V power supply type)
--------------------------------	---

Cable name	1ch	2ch	3ch
F020 cable	○		
F021 cable	○	○	
F022 cable	○	○	○

**Precautions**  
The circles indicate the used channel.

**MPG**  
Connector : CDA-15P  
Contact : CD-PC-111x12  
Case : HDA-CTH  
Recommended manufacturer: Hirose Electric

**(Note)** Fold the cable shield over the sheath, and wrap copper foil tape over it. Connect the wound copper foil tape to the connector's GND plate.

Connector name : MPG

**MPG**

1HA	1		
1HB	2		
+12V			
	9		
0V			
2HA	3		} 1ch
2HB	4		
+12V			
	12		} 2ch
	11		
0V			
3HA	5		} 3ch
3HB	6		
+12V			
	14		} 3ch
	13		
0V			

FG

Wire material : B-22(19)U x 2SJ-1 x 9  
Recommended manufacturer : Sumitomo Electric Industries

Crimp terminal : V1.25-3x12  
Recommended manufacturer : JST

2.4 G020/G021/G022 Cable

Cable type: G020/G021/G022 cable	Application: Manual pulse generator (5V power supply type)
----------------------------------	--

Cable name	1ch	2ch	3ch
G020 cable	○		
G021 cable	○	○	
G022 cable	○	○	○

**Precautions**  
The circles indicate the used channel.

**MPG**  
Connector : CDA-15P  
Contact : CD-PC-111x11  
Case : HDA-CTH  
Recommended manufacturer: Hirose Electric

(Note) Fold the cable shield over the sheath, and wrap copper foil tape over it.  
Connect the wound copper foil tape to the connector's GND plate.

Connector name : MPG

**MPG**

1HA	1	1ch
1HB	2	
+5V	7	2ch
0V	9	
2HA	3	3ch
2HB	4	
+5V	8	1ch
0V	11	
3HA	5	2ch
3HB	6	
0V	13	3ch
FG		

Wire material : B-22(19)U x 2SJ-1 x 9  
Recommended manufacturer : Sumitomo Electric Industries

Crimp terminal : V1.25-3x12  
Recommended manufacturer : JST

2.5 G023/G024 Cable

Cable type: G023/G024 cable	Application: Manual pulse generator (5V power supply type)
-----------------------------	--

**Control unit**  
(Connect to ENC connector)

**ENC**  
Connector : 10120-3000VE  
Case : 10320-52F0-008  
Recommended manufacturer : 3M

**ENC**

1HA	8	1ch
1HB	18	
5VDC	10	2ch
GND	5	
2HA	7	1ch
2HB	17	
5VDC	20	2ch
GND	15	
FG		

Wire material: UL1061-2464 AWG24 x 6P  
Recommended manufacturer : Oki Electric Cable

Crimp terminal: V1.25-3 x 8  
Recommended manufacturer: JST

  

(Note) Fold the cable shield over the sheath, and wrap copper foil tape over it.  
Connect the wound copper foil tape to the connector's GND plate.

Manual pulse generator cable channel		
	1	2
G023 cable	○	
G024 cable	○	○

○ : Usable channel

2.6 FCUA-R030 Cable

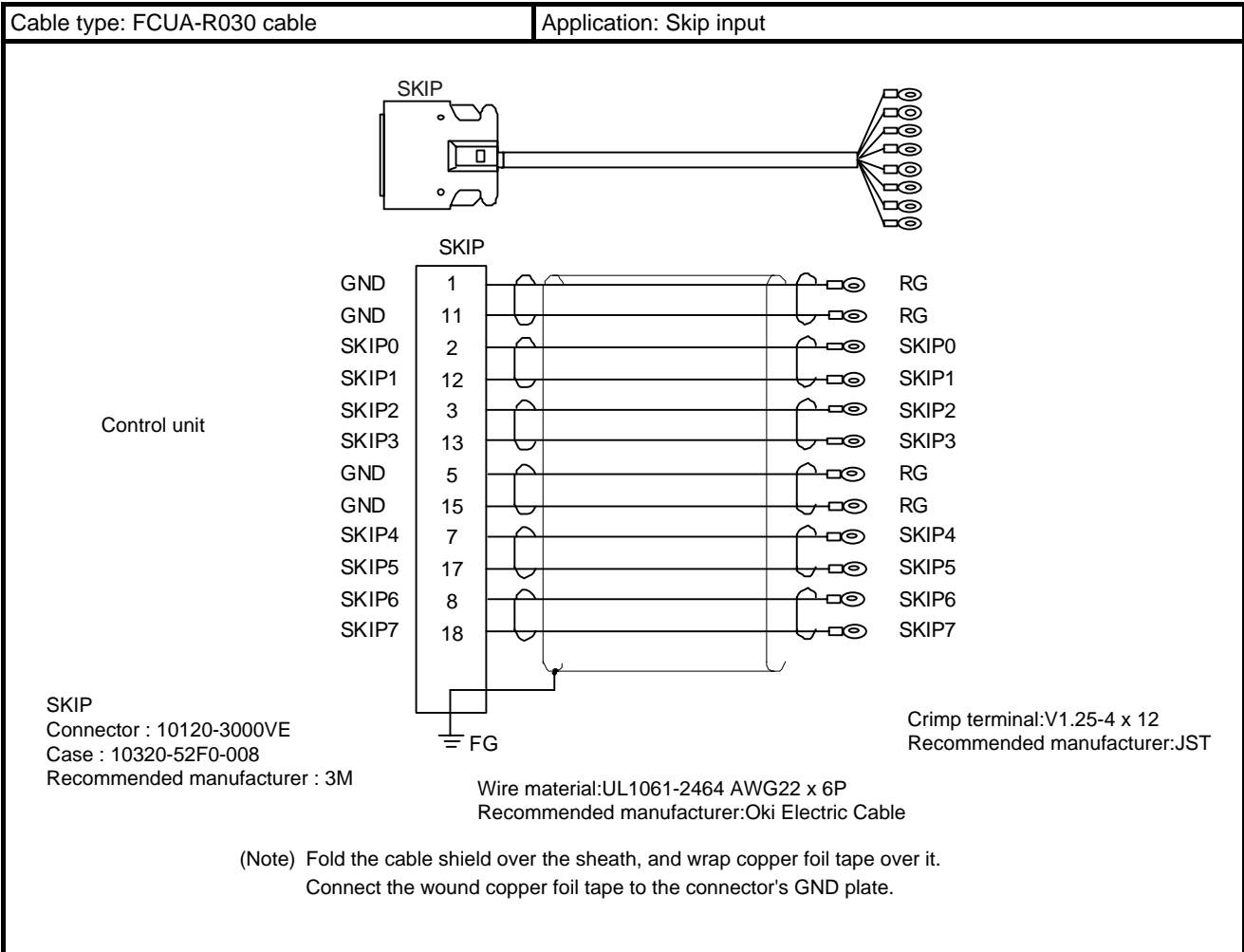

2.7 FCUA-R031 Cable

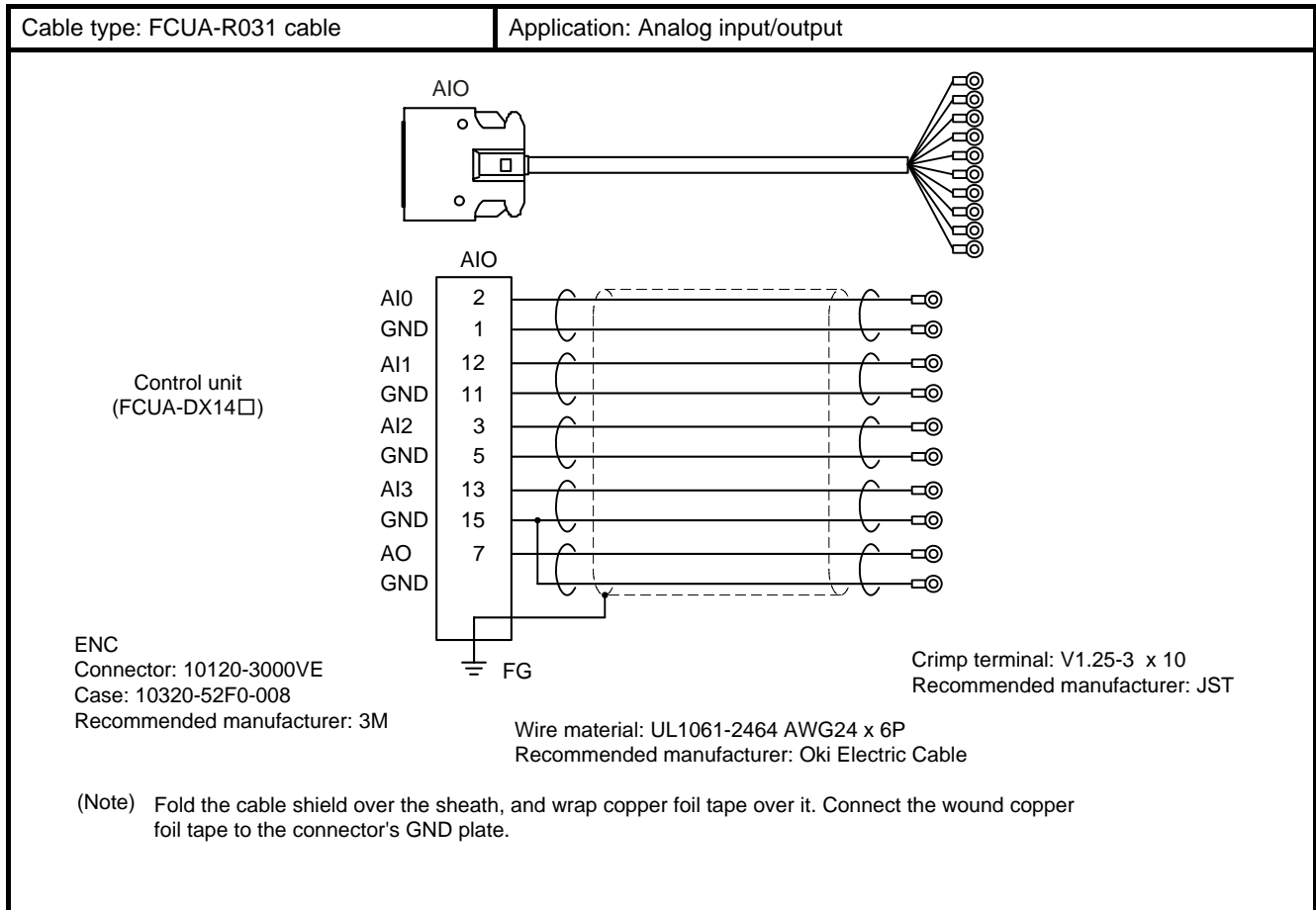

2.8 G031/G032 Cable

Cable type: G031/G032 cable	Application: RS-232C for display unit
-----------------------------	---------------------------------------

Cable name	1ch	2ch
G031 cable	○	
G032 cable	○	○

**Precautions**

1. The circles indicate the used channel.
2. The signal names shown in parentheses are equivalent to the generic names.
3. Connect to the serial communication connector of the display unit. Use F034/G035 cable when connecting to the serial communication connector of the control unit.

[SIOPC]  
Connector : 10120-3000VE  
(10120-6000EL)  
Case : 10320-52F0-008  
(10320-3210-000)  
Recommended manufacturer: 3M

**(Note)** Fold the cable shield over the sheath, and wrap copper foil tape over it. Connect the wound copper foil tape to the connector's GND plate.

Connector name: SIOPC

Connector name : 1ch

Connector name : 2ch

[SIOPC]

SD1(TXD1)	12		2
RD1(RXD1)	2		3
RS1(RTS1)	13		4
CS1(CTS1)	3		5
ER1(DTR1)	14		20
DR1(DSR1)	6		6
DCD1(DCD1)	4		8
RI1(RI1)	16		22
0V	1		7
SD2(TXD2)	17		2
RD2(RXD2)	7		3
RS2(RTS2)	18		4
CS2(CTS2)	8		5
ER2(DTR2)	19		20
DR2(DSR2)	10		6
DCD2(DCD2)	9		8
RI2(RI2)	20		22
0V	11		7

Wire material : UL1061-2464 AWG24 × 12P  
Recommended manufacturer: Oki Electric Cable

[1ch]  
Connector : CDB-25S  
Contact : CD-SC-111 x 9  
Lock nut : HD-LNA x 2  
Recommended manufacturer:  
Hirose Electric

[2ch]  
Connector : CDB-25S  
Contact : CD-SC-111 x 9  
Lock nut : HD-LNA x 2  
Recommended manufacturer:  
Hirose Electric

173



2.9 F034/F035 Cable

Cable type: F034/F035 cable	Application: RS-232C for control unit
-----------------------------	---------------------------------------

Cable name	1ch	2ch
G034 cable	○	
G035 cable	○	○

**Precautions**

1. The circles indicate the used channel.
2. The signal names shown in parentheses are equivalent to the generic names.
3. Connect to the serial communication connector of the control unit. Use G031/G032 cable when connecting to the serial communication connector of the display unit.

[SIO]  
Connector : 10120-3000VE  
Case : 10320-52F0-008  
Recommended manufacturer: 3M

**(Note)** Fold the cable shield over the sheath, and wrap copper foil tape over it. Connect the wound copper foil tape to the connector's GND plate.

Connector name: SIO

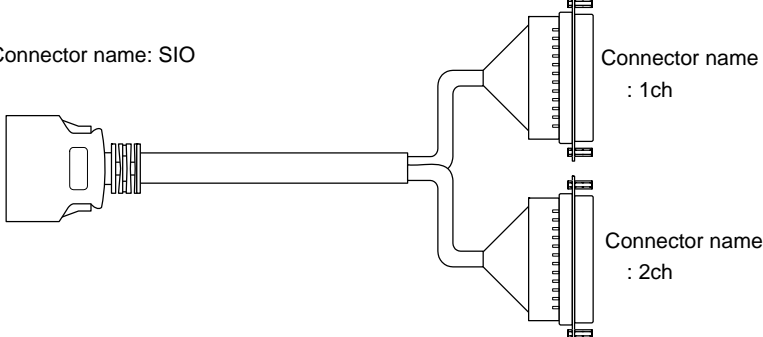

Connector name : 1ch

Connector name : 2ch

[SIO]	1ch
SD1(TXD1)	2
RD1(RXD1)	3
RS1(RTS1)	4
CS1(CTS1)	5
ER1(DTR1)	20
DR1(DSR1)	6
Reserved	8
Reserved	9
0V	7

[SIO]	2ch
SD2(TXD2)	2
RD2(RXD2)	3
RS2(RTS2)	4
CS2(CTS2)	5
ER2(DTR2)	20
DR2(DSR2)	6
Reserved	8
Reserved	9
0V	7

[1ch]  
Connector : CDB-25S  
Contact : CD-SC-111x9  
Lock nut : HD-LNax2  
Recommended manufacturer: Hirose Electric

[2ch]  
Connector : CDB-25S  
Contact : CD-SC-111x9  
Lock nut : HD-LNax2  
Recommended manufacturer: Hirose Electric

Wire material : UL1061-2464 AWG24 × 12P  
Recommended manufacturer: Oki Electric Cable

174

2.10 FCUA-R050/R054 Cable

Cable type: FCUA-R050/R054 cable	Application: Encoder input
----------------------------------	----------------------------

Connector name: ENG

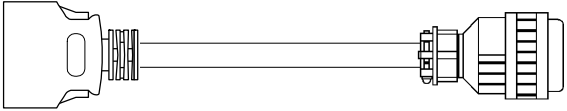

Connector : MS3106B20-29S  
Cable clamp : MS3057-12A  
Recommended manufacturer: ITT Cannon

FCUA-R050 cable

ENC1  
Plug : 10120-3000VL  
Shell : 10320-52F0-008  
Recommended manufacturer : 3M

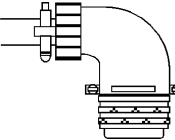

Connector : MS3108B20-29S  
Cable clamp : MS3057-12A  
Recommended manufacturer: ITT Cannon

FCUA-R054 cable

ENC1                      Twist

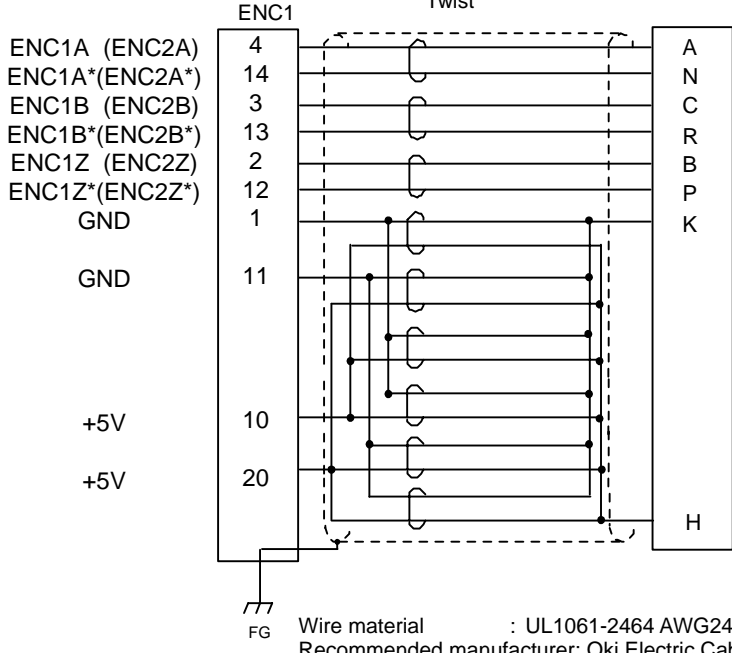

ENC1A (ENC2A)	4	A
ENC1A*(ENC2A*)	14	N
ENC1B (ENC2B)	3	C
ENC1B*(ENC2B*)	13	R
ENC1Z (ENC2Z)	2	B
ENC1Z*(ENC2Z*)	12	P
GND	1	K
GND	11	
+5V	10	
+5V	20	H

FG      Wire material : UL1061-2464 AWG24 × 12P  
Recommended manufacturer: Oki Electric Cable

**(Note)** Fold the cable shield over the sheath, and wrap copper foil tape over it. Connect the wound copper foil tape to the connector's GND plate.

2.11 F070 Cable

Cable type: F070 cable	Application: 24VDC input
------------------------	--------------------------

DCIN  
 Connector :2-178288-3  
 Contact :1-175218-5 x 3  
 Recommended manufacturer:Tyco Electronics AMP

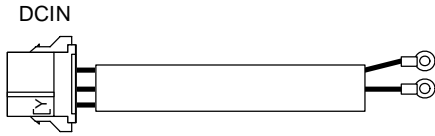
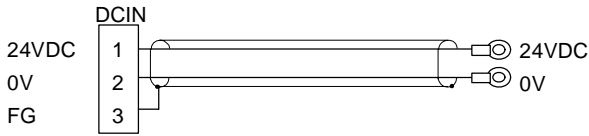
Wire material:B-18(19)U x 2SJ-1 x 9  
 Recommended manufacturer:  
 Sumitomo Electric Industries

Crimp terminal:V1.25-3 or V1.25-4 x 2  
 Recommended manufacturer:JST

2.12 F110 Cable

Cable type: F110 cable	Application: 24VDC input, power OFF detection
------------------------	---

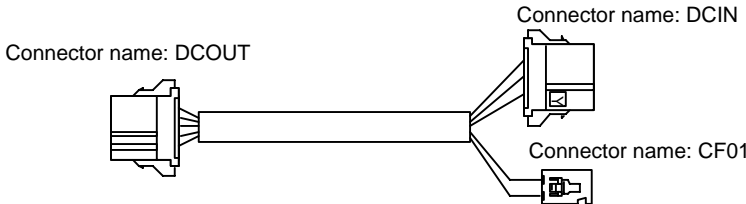
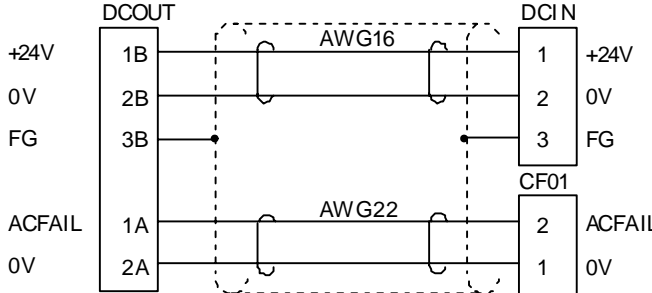
Connector : 2-178288-3  
 Contact : 1-175218-5 x 3  
 Recommended manufacturer :  
 Tyco Electronics AMP

Connector : 51030-0230  
 Cotact : 50084-8160 x 2  
 Recommended maker : MOLEX

Connector : 3-178127-6  
 Contact : 1-175218-5 (For AWG16) x 3  
 : 1-175217-5 (For AWG22) x 2  
 Recommended manufacturer:Tyco Electronics AMP

Wire material : UL2464 2 x 22AWG+2 x 16AWG SS-95138  
 Recommended manufacturer : DDK

2.13 F120 Cable

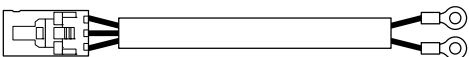
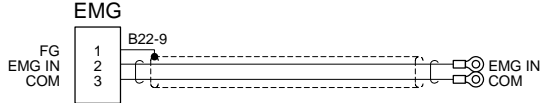
Cable type: F120 cable	Application: Emergency stop
<p>Connector name : EMG</p> 	
<p>Connector : 51030-0330                  Contact : 50084-8160 x 3                  Recommended manufacturer : MOLEX</p>	<p>EMG</p>  <p>Wiring diagram showing terminals: FG (1), EMG IN (2), COM (3). B22-9 terminal is connected to terminal 1. EMG IN and COM terminals are connected to terminals 2 and 3 respectively.</p> <p>Wire material : B-22(19)U x 2SJ-1 x 9                  Recommended manufacturer : Sumitomo Electric Industries</p> <p>Crimp terminal : V1.25-3 x 2                  Recommended manufacturer : JST</p>

2.14 G123 Cable

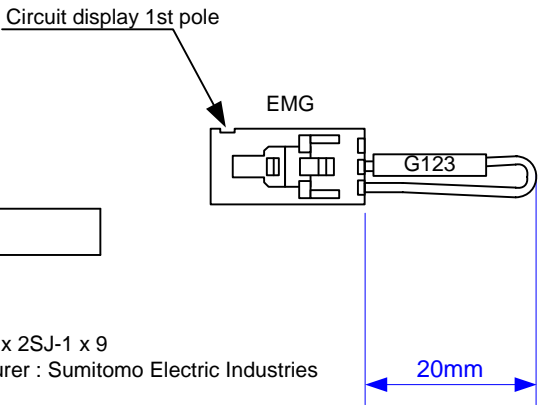
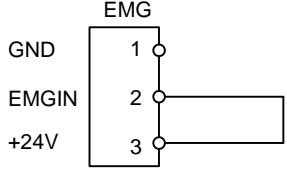
Cable type: G123 cable	Application: Emergency stop terminator
<p>Connector name : EMG</p> 	
<p>Connector : 51030-0330                  Cotact : 50084-8160 x 2                  Recommended manufacturer : MOLEX</p>	<p>EMG</p>  <p>Wiring diagram showing terminals: GND (1), EMGIN (2), +24V (3).</p> <p>Wire material : B-22(19)U x 2SJ-1 x 9                  Recommended manufacturer : Sumitomo Electric Industries</p> <p>20mm</p>

2.15 F130 Cable

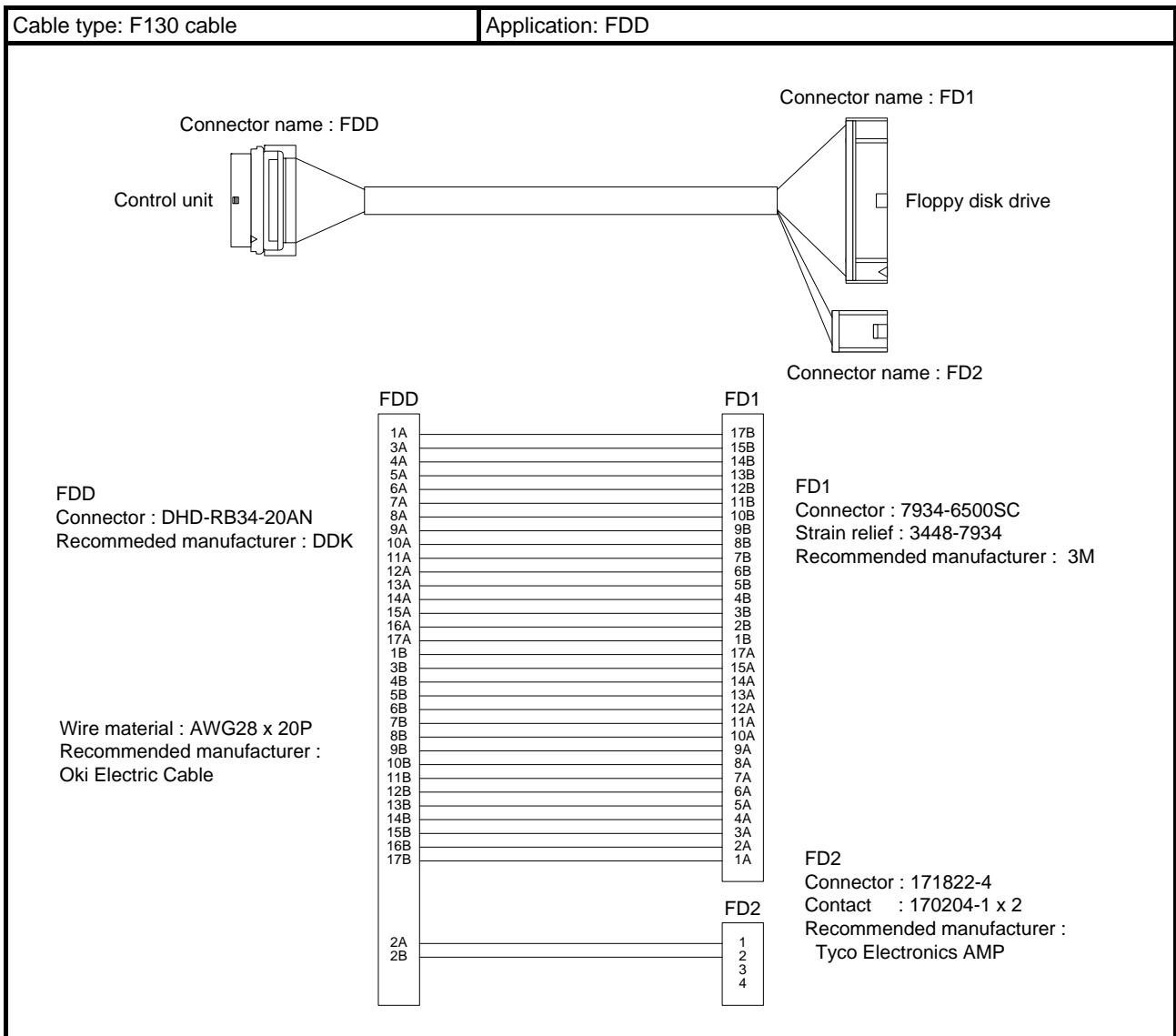

2.16 F140 Cable

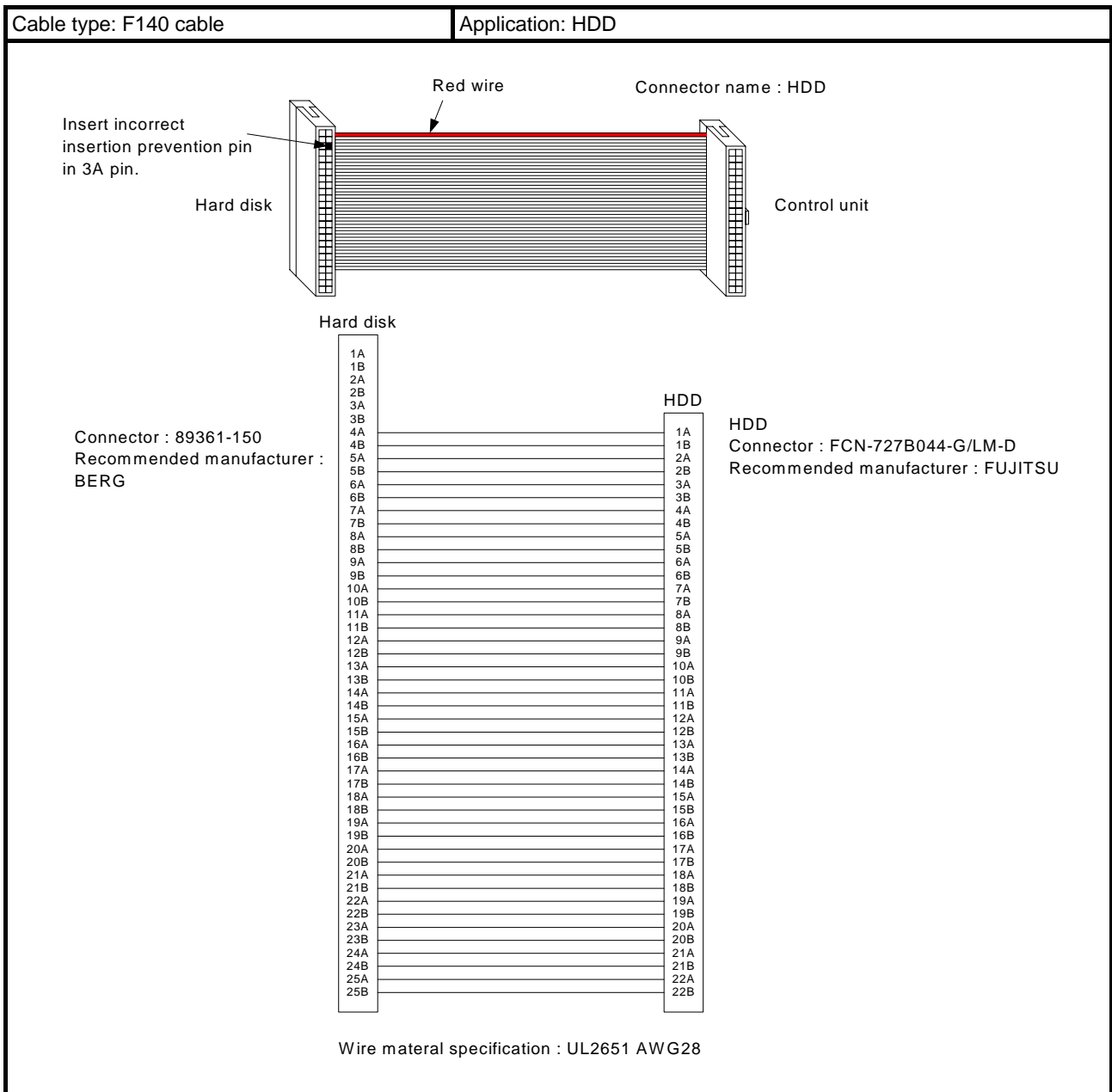

2.17 G170 Cable

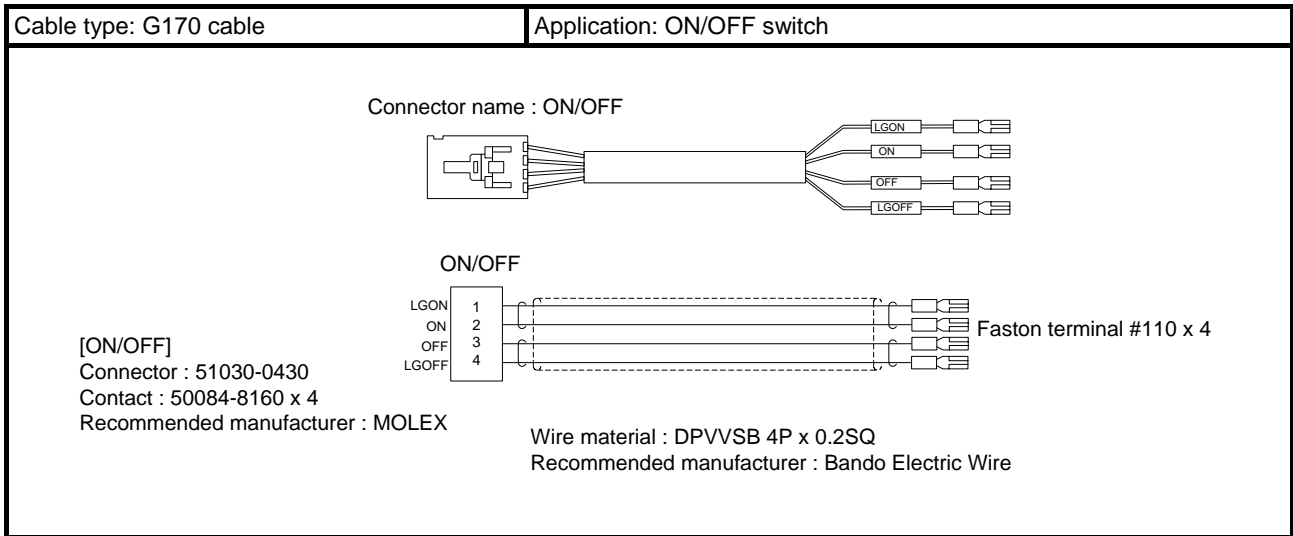

2.18 G171 Cable

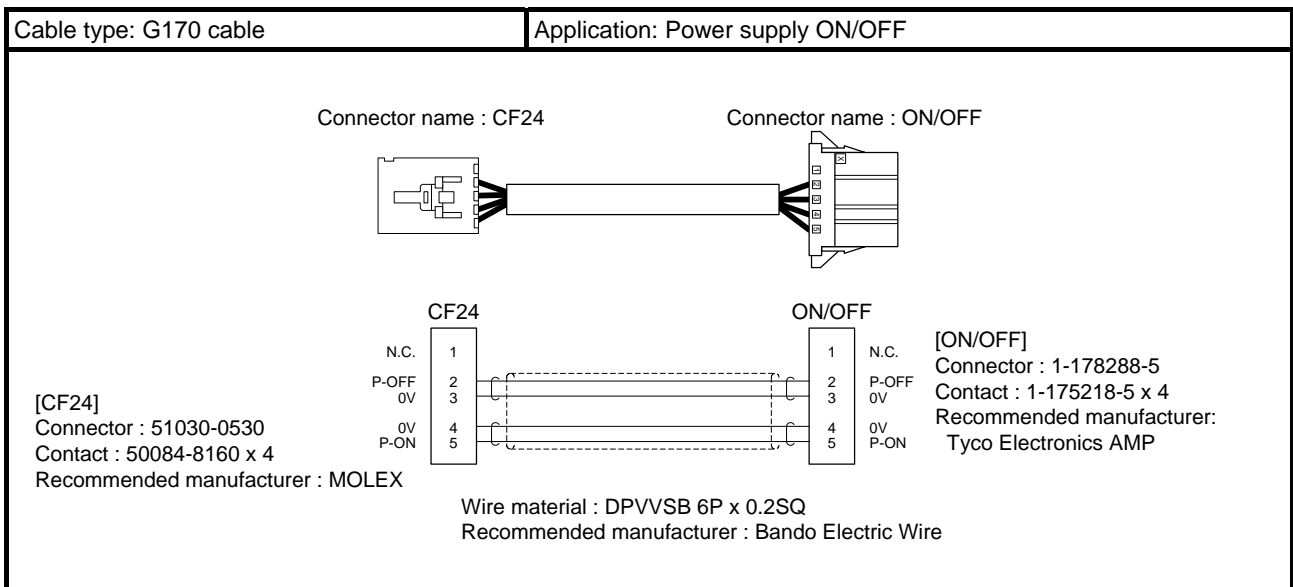

2.19 F170 Cable

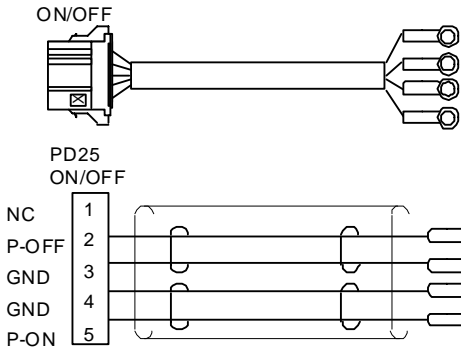
Cable type: F170 cable	Application: ON/OFF switch for PD25																															
<p>ON/OFF Connector: 1-178288-5 Contact: 1-175218-5 Recommended manufacturer: Tyco Electronics AMP</p>		<p>Crimp terminal: V1.25-3 or V1.25-4 Recommended manufacturer: JST</p>																														
<p>(Note) Select the crimp terminal suitable for the terminal block and external power supply you use.</p>	<p>Wire material: DPVVS 3P×0.3mm<sup>2</sup> Recommended manufacturer: Bando Electric Wire</p>	<p>PD25 ON/OFF</p> <table border="1" style="margin-left: auto; margin-right: auto;"> <tr><td>NC</td><td>1</td><td></td><td></td><td></td><td></td></tr> <tr><td>P-OFF</td><td>2</td><td></td><td></td><td></td><td>OFF-1</td></tr> <tr><td>GND</td><td>3</td><td></td><td></td><td></td><td>OFF-2</td></tr> <tr><td>GND</td><td>4</td><td></td><td></td><td></td><td>ON-1</td></tr> <tr><td>P-ON</td><td>5</td><td></td><td></td><td></td><td>ON-2</td></tr> </table>	NC	1					P-OFF	2				OFF-1	GND	3				OFF-2	GND	4				ON-1	P-ON	5				ON-2
NC	1																															
P-OFF	2				OFF-1																											
GND	3				OFF-2																											
GND	4				ON-1																											
P-ON	5				ON-2																											

2.20 FCUA-R211 Cable

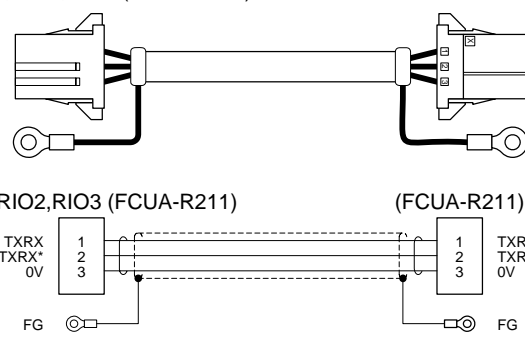
Cable type: FCUA-R211 cable	Application: Remote I/O	
<p>Connector : 1-178288-3 Contact : 1-175218-2 x 3 Recommended manufacturer: Tyco Electronics AMP</p>	<p>Connector name : RIO1,RIO2,RIO3 (FCUA-R211)</p> <p>Connector name : (FCUA-R211)</p> 	<p>Wire material :MVVS 3C x 0.5mm<sup>2</sup> (MIC 3C x 0.5mm<sup>2</sup>) Recommended manufacturer : Takeuchi Densen</p>
<p>Precautions</p> <ol style="list-style-type: none"> <li>(1) Protect both ends of the cable with insulated bushing.</li> <li>(2) RIO1, RIO2 and RIO3 can be used commonly.</li> <li>(3) This is equivalent to the SH41 cable with shield.</li> </ol>	<p>Connector : 1-178288-3 Contact : 1-175218-2 x 3 Recommended manufacturer : Tyco Electronics AMP</p>	<p>Wire material : DPVVS 3P×0.3mm<sup>2</sup> Recommended manufacturer: Bando Electric Wire</p>



2.21 G291 Cable

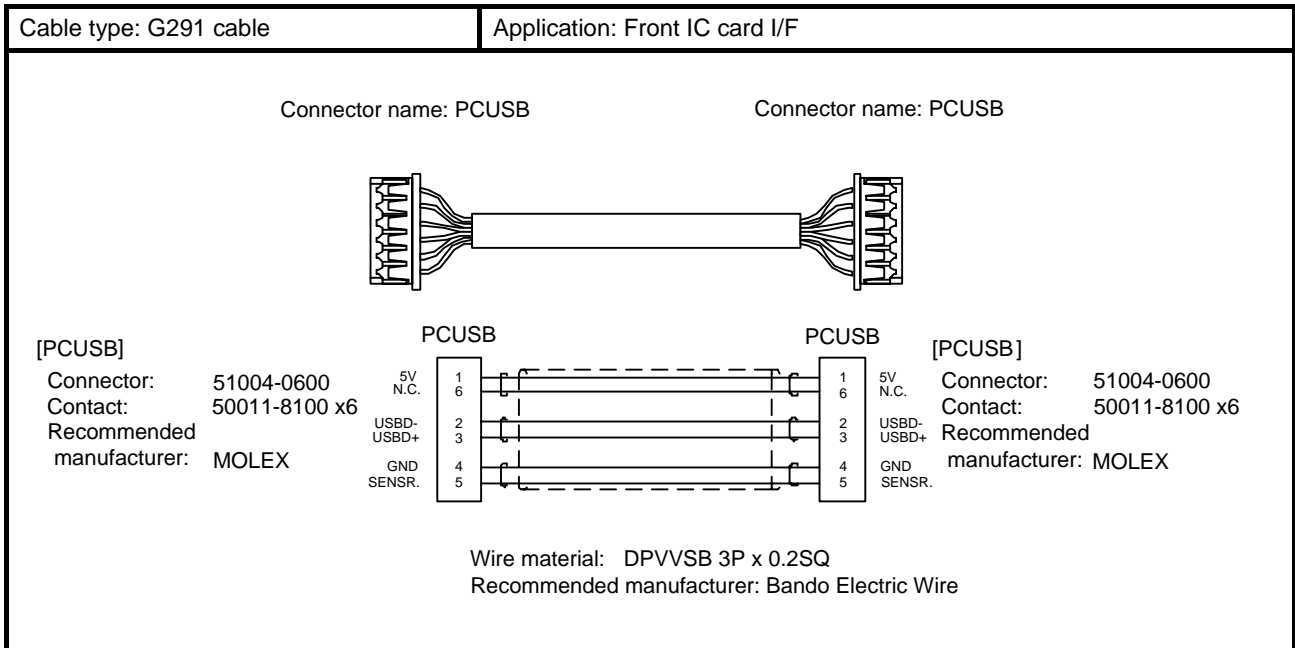

2.22 G300 Cable

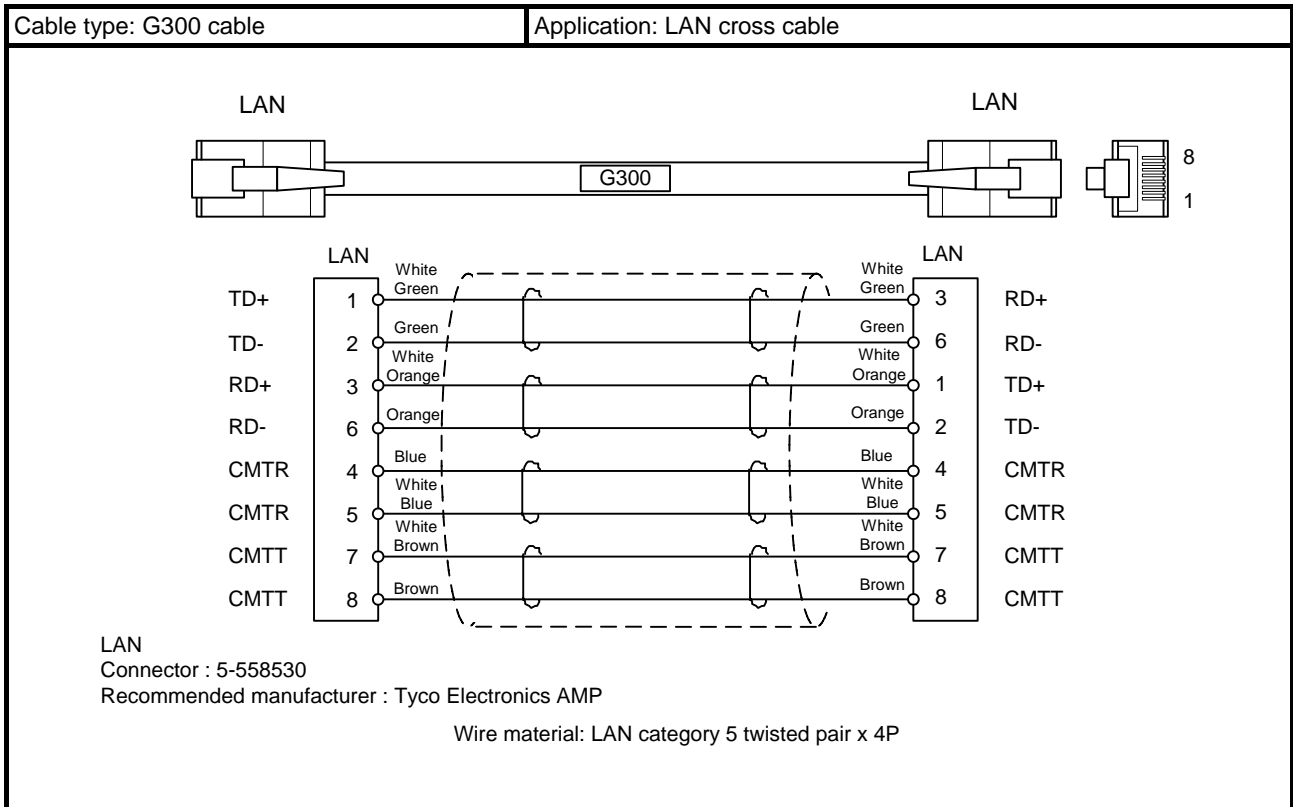

2.23 G301 Cable

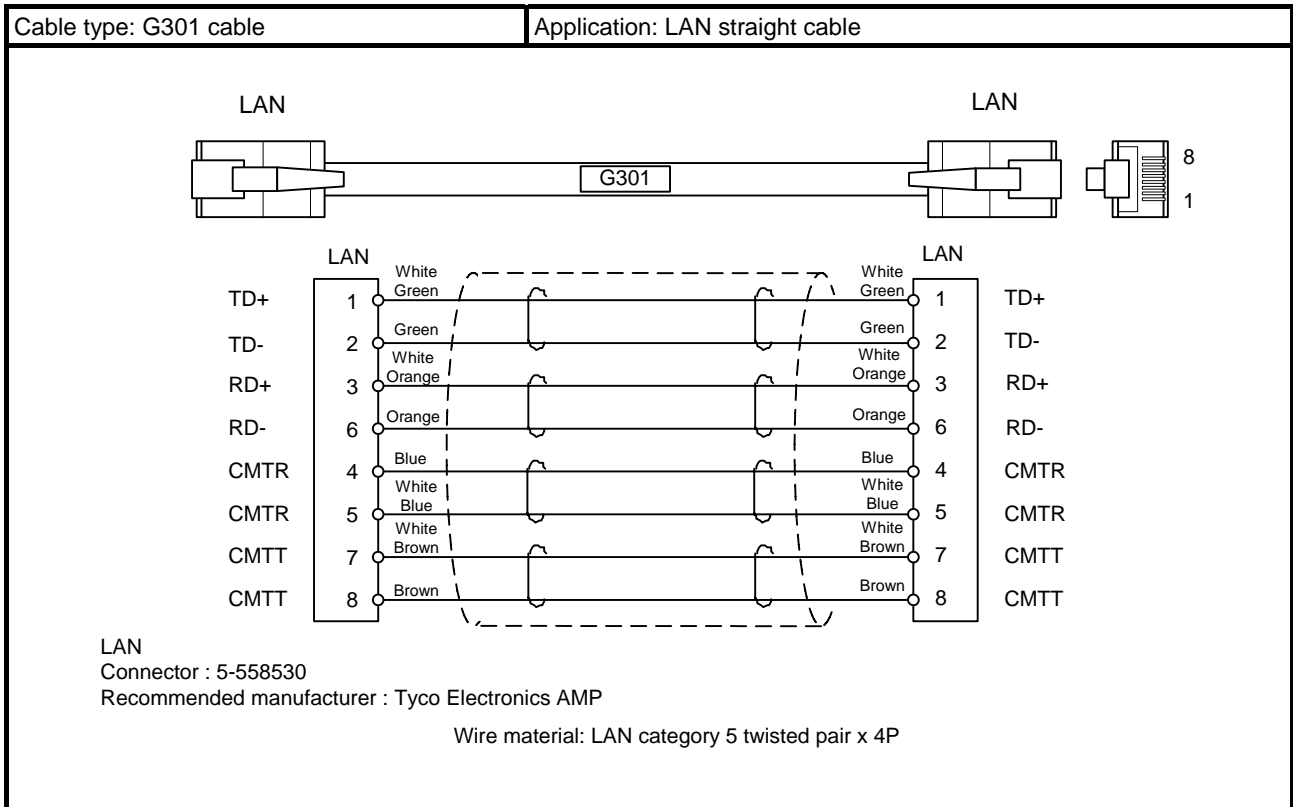

2.24 R300 Cable

Cable type: R300 cable	Application: DI/DO cable Single-side connector not available
<p>Connector name : DI-L/DO-L, DI-R/DO-R</p> <p>Connector : 7940-6500SC Recommended manufacturer : 3M</p>  <p>Wire material : B40-S Recommended manufacturer : Oki Electric Cable</p>	

2.25 R301 Cable

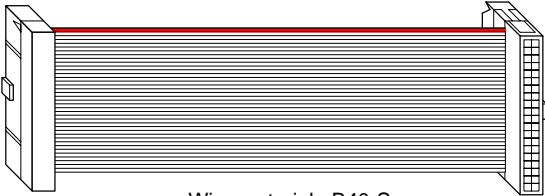
Cable type: R301 cable	Application: DI/DO cable Double-side connector available
<p>Connector name : DI-L/DO-L, DI-R/DO-R</p> <p>Connector : 7940-6500SC Recommended manufacturer: 3M</p>  <p>Wire material : B40-S Recommended manufacturer : Oki Electric Cable</p> <p>Connector : 7940-6500SC Strain relief : 3448-7940 Recommended manufacturer : 3M</p>	

2.26 G310 Cable

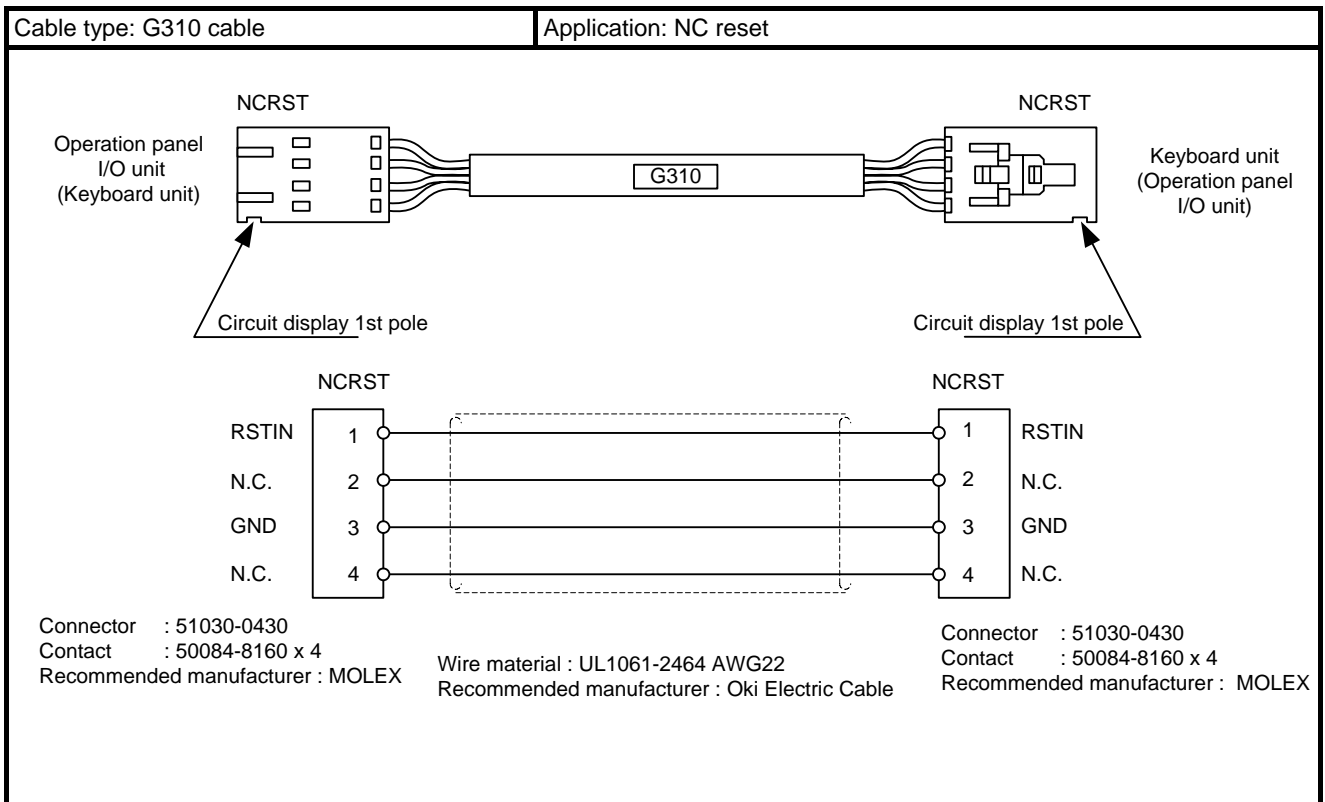

2.27 G380 Cable

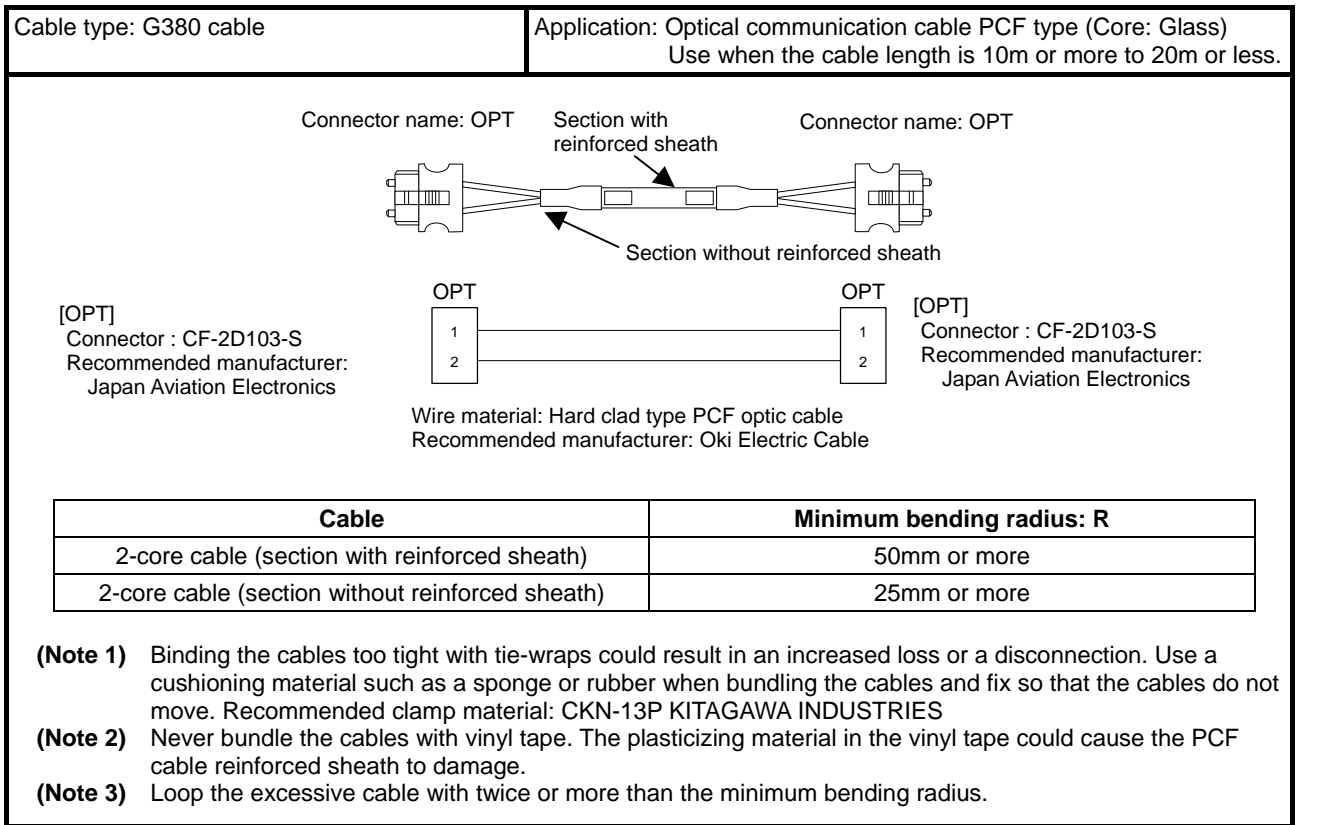

2.28 G395 Cable

Cable type: G395 cable	Application: Optical communication cable POF type (Core: Plastic) Use when wiring outside of the panel with a cable of 10m or less.
------------------------	--

Connector name: OPT      Section with reinforced sheath      Connector name: OPT

Section without reinforced sheath

[OPT]  
Connector : PF-2D103  
Recommended manufacturer:  
Japan Aviation Electronics

OPT      OPT

1      1

2      2

[OPT]  
Connector : PF-2D103  
Recommended manufacturer:  
Japan Aviation Electronics

Wire material: ESCA Premium  
Recommended manufacturer: MITSUBISHI RAYON

Cable	Minimum bending radius: R
2-core cable (section with reinforced sheath)	50mm or more
2-core cable (section without reinforced sheath)	30mm or more

**(Note 1)** Binding the cables too tight with tie-wraps could result in an increased loss or a disconnection. Use a cushioning material such as a sponge or rubber when bundling the cables and fix so that the cables do not move. Recommended clamp material: CKN-13P KITAGAWA INDUSTRIES  
**(Note 2)** Never bundle the cables with vinyl tape. The plasticizing material in the vinyl tape could cause the POF cable to break.  
**(Note 3)** Loop the excessive cable with twice or more than the minimum bending radius.

2.29 G396 Cable

Cable type: G396 cable	Application: Optical communication cable POF type (Core: Plastic) Use when wiring in the panel with a cable of 10m or less.
------------------------	--

Connector name: OPT      Connector name: OPT

[OPT]  
Connector : PF-2D103  
Recommended manufacturer:  
Japan Aviation Electronics

OPT      OPT

1      1

2      2

[OPT]  
Connector : PF-2D103  
Recommended manufacturer:  
Japan Aviation Electronics

Wire material: ESKA Premium  
Recommended manufacturer: MITSUBISHI RAYON

Cable	Minimum bending radius: R
2-core parallel cable	30mm or more

**(Note 1)** Binding the cables too tight with tie-wraps could result in an increased loss or a disconnection. Use a cushioning material such as a sponge or rubber when bundling the cables and fix so that the cables do not move. Recommended clamp material: CKN-13P KITAGAWA INDUSTRIES  
**(Note 2)** Never bundle the cables with vinyl tape. The plasticizing material in the vinyl tape could cause the POF cable to break.  
**(Note 3)** Loop the excessive cable with twice or more than the minimum bending radius.

2.30 G430 Cable

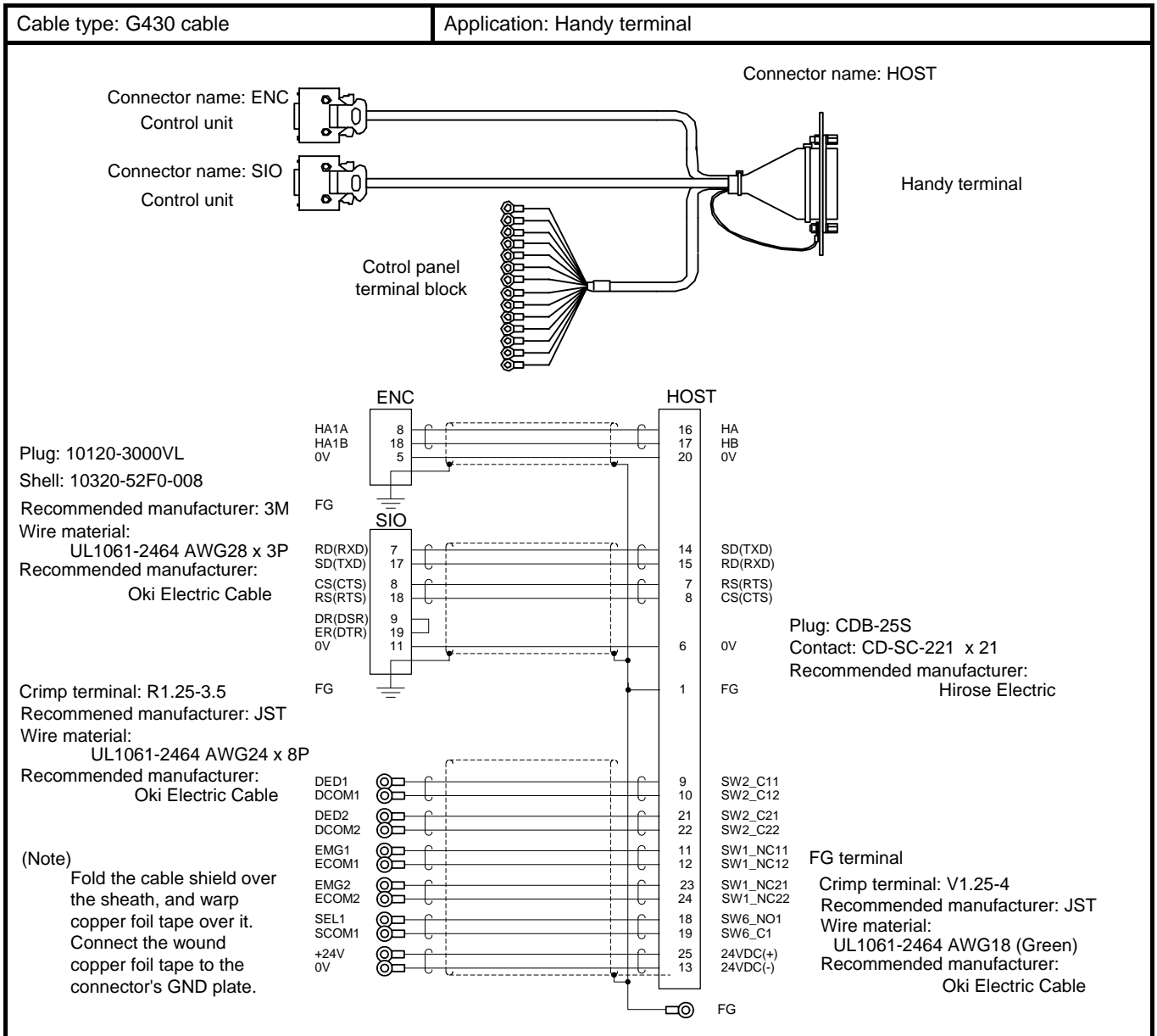

2.31 SH21 Cable

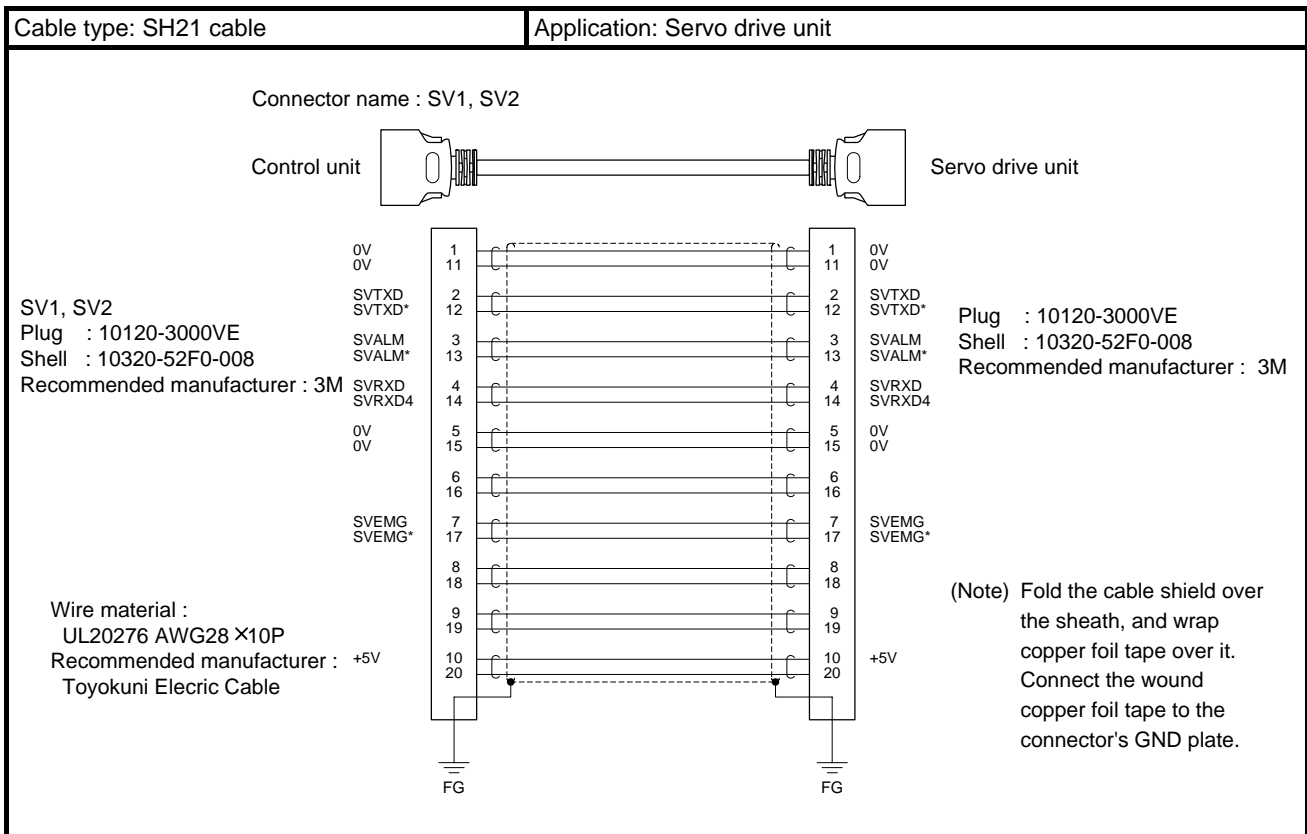

2.32 SH41 Cable

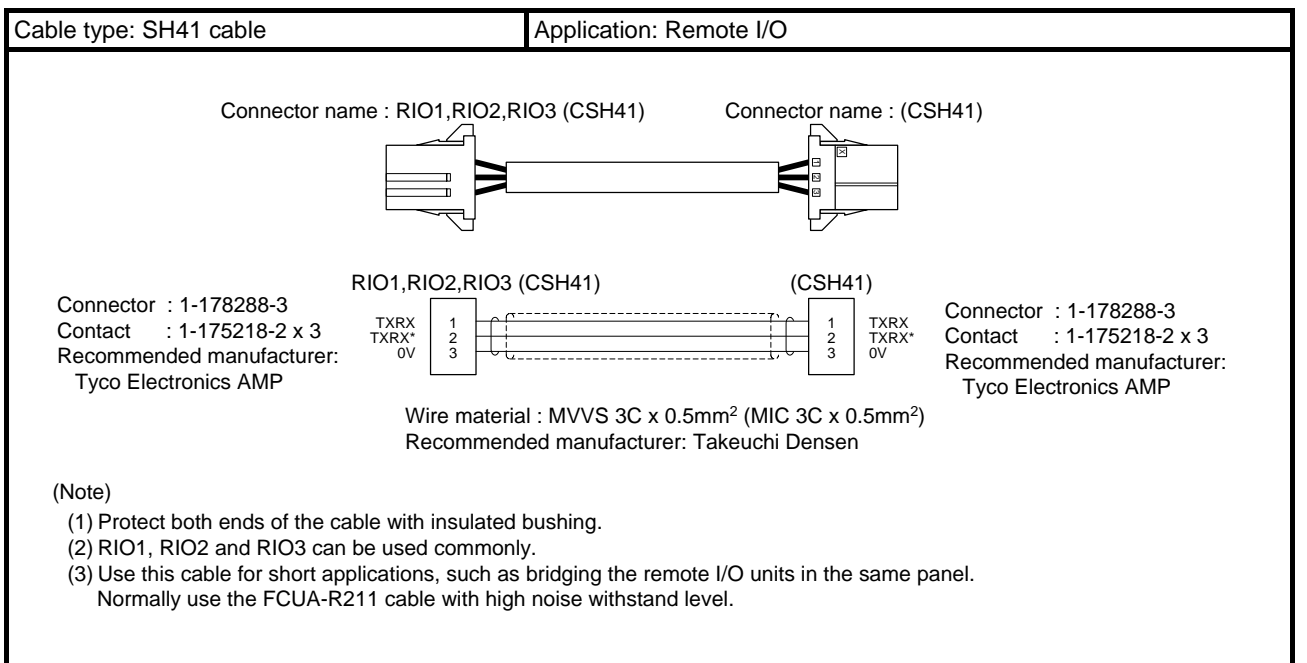

2.33 E-TM Terminator Connector

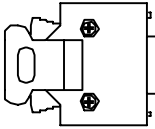
Cable type: E-TM	Application: OPI connector terminator								
<p>E-TM terminator connector</p> <div style="display: flex; justify-content: space-between; align-items: flex-start;"> <div style="width: 30%;"> <p>Connector name: E-TM</p>  </div> <div style="width: 30%;"> <p>E-TM</p> <table border="1" style="border-collapse: collapse; text-align: center;"> <tr><td style="padding: 2px 5px;">1</td><td style="padding: 2px 5px;">GND</td></tr> <tr><td style="padding: 2px 5px;">8</td><td style="padding: 2px 5px;">+5V</td></tr> <tr><td style="padding: 2px 5px;">10</td><td style="padding: 2px 5px;">EMG+</td></tr> <tr><td style="padding: 2px 5px;">20</td><td style="padding: 2px 5px;">EMG-</td></tr> </table> </div> <div style="width: 35%;"> <p>[E-TM]</p> <p>Plug: 10120-3000VL Shell: 10320-52F0-008 Recommended manufacturer: 3M</p> <p>(Note) The cable led-in hole must be closed.</p> </div> </div> <p style="text-align: center; margin-top: 10px;">Wire material: UL1007 AWG22</p>		1	GND	8	+5V	10	EMG+	20	EMG-
1	GND								
8	+5V								
10	EMG+								
20	EMG-								

2.34 R-TM Terminator Connector

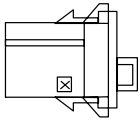
Cable type: R-TM	Application: Remote I/O interface terminator						
<p>R-TM terminal connector</p> <div style="display: flex; justify-content: space-between; align-items: flex-start;"> <div style="width: 30%;"> <p>Connector name: R-TM</p>  </div> <div style="width: 30%;"> <p>R-TM</p> <table border="1" style="border-collapse: collapse; text-align: center;"> <tr><td style="padding: 2px 5px;">3</td><td style="padding: 2px 5px;">0V</td></tr> <tr><td style="padding: 2px 5px;">2</td><td style="padding: 2px 5px;">TXRX*</td></tr> <tr><td style="padding: 2px 5px;">1</td><td style="padding: 2px 5px;">TXRX</td></tr> </table> <p style="text-align: right; margin-top: 5px;">100Ω</p> </div> <div style="width: 35%;"> <p>[R-TM]</p> <p>Connector: 1-178288-3 (x type) Contact: 1-175216-2 x 2 Recommended manufacturer: Tyco Electronics AMP Resistor: 100Ω 1/4W</p> </div> </div> <p><b>Manufacturing precautions</b></p> <ol style="list-style-type: none"> <li>(1) The parts used shall be Mitsubishi recommended parts. Equivalent parts may be used providing they are compatible with the specifications.</li> <li>(2) Cover the 100Ω terminator with a black insulation tube.</li> <li>(3) Stamp the connector name "R-TM" in white on the rear of the connector.</li> </ol>		3	0V	2	TXRX*	1	TXRX
3	0V						
2	TXRX*						
1	TXRX						



## Appendix 3. Connectors

### 3.1 Connectors for Control Unit

#### 3.1.1 Operation Panel I/O Unit Connecting Connector (OPI)

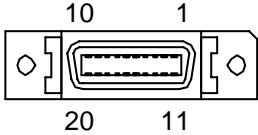
Name : OPI				
				
<Cable side connector type>				
Plug : 10120-3000VE				
Shell : 10320-52F0-008				
Recommended manufacturer : 3M				
1		0V	11	0V
2		NC	12	NC
3		CMTT	13	CMTR
4		NC	14	NC
5		0V	15	0V
6	I	TD+	16	I TD-
7	O	RD+	17	O RD-
8	O	5V	18	NC
9	O	TXRXD	19	O TXRXD*
10	O	EMG+	20	O EMG-

\* Connect connector case with FG pattern.

#### 3.1.2 Auxiliary Axis Servo Drive Unit Connecting Connector (SV1)

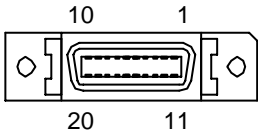
Name : SV1				
				
<Cable side connector type>				
Plug : 10120-3000VE				
Shell : 10320-52F0-008				
Recommended manufacturer : 3M				
1		0V	11	0V
2	O	SVTXD1	12	O SVTXD1*
3	I	SVALM1	13	I SVALM1*
4	I	SVRDX1	14	I SVRDX1*
5		0V	15	0V
6		NC	16	NC
7	O	SVEMG1	17	O SVEMG1*
8		NC	18	NC
9		NC	19	NC
10		NC	20	NC

\* Connect connector case with FG pattern.

3.1.3 Auxiliary Axis Servo Drive Unit Connecting Connector (SV2)

Name : SV2

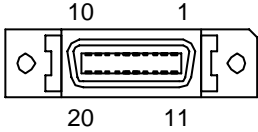

<Cable side connector type>  
 Plug : 10120-3000VE  
 Shell : 10320-52F0-008  
 Recommended manufacturer : 3M

1		0V	11		0V
2	O	SVTXD2	12	O	SVTXD2*
3	I	SVALM2	13	I	SVALM2*
4	I	SVRDX2	14	I	SVRDX2*
5		0V	15		0V
6		NC	16		NC
7	O	SVEMG2	17	O	SVEMG2*
8		NC	18		NC
9		NC	19		NC
10		NC	20		NC

\* Connect connector case with FG pattern.

3.1.4 Skip Input Connector (SKIP)

Name : SKIP

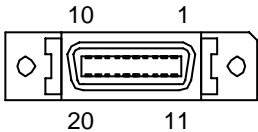

<Cable side connector type>  
 Plug : 10120-3000VE  
 Shell : 10320-52F0-008  
 Recommended manufacturer : 3M

1		0V	11		0V
2	I	SKIP0	12	I	SKIP1
3	I	SKIP2	13	I	SKIP3
4		NC	14		NC
5		0V	15		0V
6		NC	16		NC
7	I	SKIP4	17	I	SKIP5
8	I	SKIP6	18	I	SKIP7
9		NC	19		NC
10		NC	20		NC

\* Connect connector case with FG pattern.

3.1.5 Serial Communication Connector (SIO)

Name : SIO

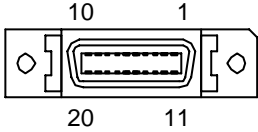

<Cable side connector type>  
 Plug : 10120-3000VE  
 Shell : 10320-52F0-008  
 Recommended manufacturer : 3M

1		0V	11		0V
2	I	RD1(RXD1)	12	O	SD1(TXD1)
3	I	CS1(CTS1)	13	O	RS1(RTS1)
4	O	DR1(DSR1)	14	I	ER1(DTR1)
5		0V	15		0V
6		NC	16		NC
7	I	RD2(RXD2)	17	O	SD2(TXD2)
8	I	CS2(CTS2)	18	O	RS2(RTS2)
9	O	DR2(DSR2)	19	I	ER2(DTR2)
10		NC	20		NC

\* Connect connector case with FG pattern.

3.1.6 Encoder / Manual Pulse Generator Connecting Connector (ENC)

Name : ENC

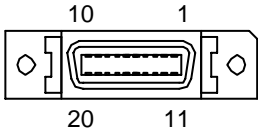

<Cable side connector type>  
 Plug : 10120-3000VE  
 Shell : 10320-52F0-008  
 Recommended manufacturer : 3M

1		0V	11		0V
2	I	ENC1C	12	I	ENC1C*
3	I	ENC1B	13	I	ENC1B*
4	I	ENC1A	14	I	ENC1A*
5		0V	15		0V
6	O	5V	16	O	5V
7	I	HA2A	17	I	HA2B
8	I	HA1A	18	I	HA1B
9		NC	19		NC
10	O	5V	20	O	5V

\* Connect connector case with FG pattern.

3.1.7 Optical Communication Connecting Connector (OPT1)

Name : OPT1

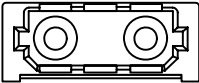

<Cable side connector type>  
 (PCF type)  
 Connector : CF-2D101-S  
 Recommended manufacturer:  
 Japan Aviation Electronics

(POF type)  
 Connector : PF-2D101  
 Recommended manufacturer:  
 Japan Aviation Electronics

**3.1.8 Remote I/O Unit Connecting Connector (RI01)**

Name : RIO1

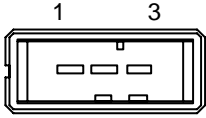

1	I/O	TXRX1
2	I/O	TXRX1*
3		0V

<Cable side connector type>  
 Connector : 1-178288-3  
 Contact : 1-175218-2 x3  
 Recommended manufacturer : Tyco Electronics AMP

**3.1.9 Remote I/O Unit Connecting Connector (RI02)**

Name : RIO2

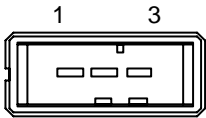

1	I/O	TXRX2
2	I/O	TXRX2*
3		0V

<Cable side connector type>  
 Connector : 1-178288-3  
 Contact : 1-175218-2 x3  
 Recommended manufacturer : Tyco Electronics AMP

**3.1.10 Emergency Stop Input Connector (EMGIN)**

Name : EMGIN

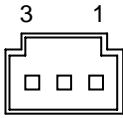

1		FG
2	I	EMG IN
3	O	+24V

<Cable side connector type>  
 Connector : 51030-0330  
 Contact : 50084-8160 x3  
 Recommended manufacturer : MOLEX

\* Always connect the EMG terminating cable (G123) when not using this input.

3.1.11 Power OFF Input Connector (CF01)

Name : CF01



1		0V
2	I	ACFAIL

<Cable side connector type>  
 Connector : 51030-0330  
 Contact : 50084-8160 x2  
 Recommended manufacturer : MOLEX

\* This connector can be used even if not connected.  
 \* Supply +24V to ACFAIL when using this connector. <sup>(Note)</sup>

**(Note)** Use this when turning the control unit power OFF from an external source such as an ON/OFF switch.

3.1.12 24VDC Input Connector (DCIN)

Name : DCIN

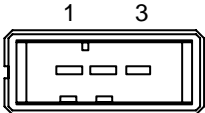

1	I	+24V
2		0V
3		FG

<Cable side connector type>  
 Connector : 2-178288-3  
 Contact : 1-175218-5 x3  
 Recommended manufacturer : Tyco Electronics AMP

3.1.13 Ethernet Connector (LAN)

Name : LAN

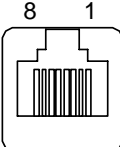

1	O	TD+
2	O	TD-
3	I	RD+
4		
5		
6	I	RD-
7		
8		

<Cable side connector type>  
 Connector : 5-569550-3  
 Recommended manufacturer : Tyco Electronics AMP

\* Connect the connector case with the FG pattern.  
 \* Use a cross cable (G300) when directly connecting to a device such as a personal computer.

3.1.14 DIO Input/Output Connector (SDIO)

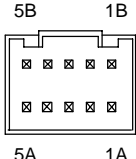
Name : SDIO																																			
			<table border="1" style="width: 100%; border-collapse: collapse; text-align: center;"> <tr> <td>1A</td><td></td><td>COM</td><td>1B</td><td></td><td>0V</td></tr> <tr> <td>2A</td><td>I</td><td>SDI1</td><td>2B</td><td>I</td><td>SDI2</td></tr> <tr> <td>3A</td><td></td><td>Reserved</td><td>3B</td><td></td><td>Reserved</td></tr> <tr> <td>4A</td><td>I</td><td>+24V</td><td>4B</td><td>O</td><td>SDO1</td></tr> <tr> <td>5A</td><td></td><td>Reserved</td><td>5B</td><td></td><td>Reserved</td></tr> </table>			1A		COM	1B		0V	2A	I	SDI1	2B	I	SDI2	3A		Reserved	3B		Reserved	4A	I	+24V	4B	O	SDO1	5A		Reserved	5B		Reserved
1A		COM	1B		0V																														
2A	I	SDI1	2B	I	SDI2																														
3A		Reserved	3B		Reserved																														
4A	I	+24V	4B	O	SDO1																														
5A		Reserved	5B		Reserved																														
<p>&lt;Cable side connector type&gt;                  Connector : 51353-1000                  Contact : 56134-9000 x6                  Recommended manufacturer : MOLEX</p>			<p>* Connect 1B with the FG pattern.                  * Supply the following voltage to COM.                  Sink : +24V                  Source : 0V</p>																																

### 3.2 Connectors for Operation Panel I/O Unit

#### 3.2.1 Manual Pulse Generator Connecting Connector (MPG)

Name : MPG

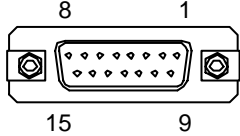

1	I	1HA	9		0V
2	I	1HB	10	O	+12V
3	I	2HA	11		0V
4	I	2HB	12	O	+12V
5	I	3HA	13		0V
6	I	3HB	14	O	+12V
7	O	+5V	15		NC
8	O	+5V			

<Cable side connector type>  
 Connector : CDA-15P  
 Contact : CD-PC-111 x11 (5V power supply type)  
           : CD-PC-111 x12 (12V power supply type)  
 Case : HDA-CTH  
 Recommended manufacturer : Hirose Electric

\* Connect connector case with FG pattern.

#### 3.2.2 24VDC Input Connector (DCIN)

Name : DCIN

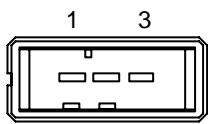

1	I	+24V
2		0V
3		FG

<Cable side connector type>  
 Connector : 2-178288-3  
 Contact : 1-175218-5 x3  
 Recommended manufacturer : Tyco Electronics AMP

#### 3.2.3 Remote I/O Unit Connecting Connector (RIO3)

Name : RIO3

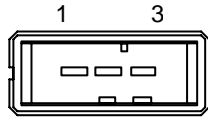

1	I/O	TXRX3
2	I/O	TXRX3*
3		0V(GND)

<Cable side connector type>  
 Connector : 1-178288-3  
 Contact : 1-175218-2 x3  
 Recommended manufacturer : Tyco Electronics AMP

3.2.4 Machine Input/Output Connector (CG31/CG32/CG33/CG34)

Name : CG31/CG32/CG33/CG34

CG31/CG33

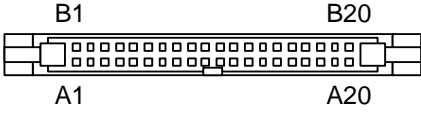

<Cable side connector type>  
 Connector : 7940-6500LC  
 Recommended manufacturer : 3M

B			A		
20	I	X0	20	I	X10
19	I	X1	19	I	X11
18	I	X2	18	I	X12
17	I	X3	17	I	X13
16	I	X4	16	I	X14
15	I	X5	15	I	X15
14	I	X6	14	I	X16
13	I	X7	13	I	X17
12	I	X8	12	I	X18
11	I	X9	11	I	X19
10	I	XA	10	I	X1A
9	I	XB	9	I	X1B
8	I	XC	8	I	X1C
7	I	XD	7	I	X1D
6	I	XE	6	I	X1E
5	I	XF	5	I	X1F
4		NC	4		NC
3		COM	3		COM
2	I	+24V	2		0V
1	I	+24V	1		0V

CG32/CG34

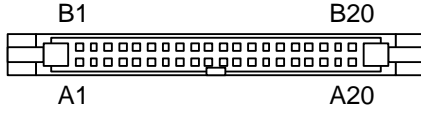

<Cable side connector type>  
 Connector : 7940-6500LC  
 Recommended manufacturer : 3M

B			A		
20	O	Y0	20	O	Y10
19	O	Y1	19	O	Y11
18	O	Y2	18	O	Y12
17	O	Y3	17	O	Y13
16	O	Y4	16	O	Y14
15	O	Y5	15	O	Y15
14	O	Y6	14	O	Y16
13	O	Y7	13	O	Y17
12	O	Y8	12	O	Y18
11	O	Y9	11	O	Y19
10	O	YA	10	O	Y1A
9	O	YB	9	O	Y1B
8	O	YC	8	O	Y1C
7	O	YD	7	O	Y1D
6	O	YE	6	O	Y1E
5	O	YF	5	O	Y1F
4		COM	4		COM
3		COM	3		COM
2	I	+24V	2		0V
1	I	+24V	1		0V

The input/output assignment differs according to the station No. setting switch. Refer to "PLC Interface Manual" for details.

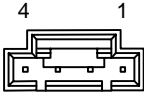

**3.2.5 Reset Switch Input Connector (NCRST)**

Name : NCRST														
	<table border="1" style="border-collapse: collapse; text-align: center;"> <tr> <td style="width: 20px;">1</td> <td style="width: 20px;">I</td> <td>RSTIN</td> </tr> <tr> <td>2</td> <td></td> <td>NC</td> </tr> <tr> <td>3</td> <td>O</td> <td>0V(GND)</td> </tr> <tr> <td>4</td> <td></td> <td>NC</td> </tr> </table>		1	I	RSTIN	2		NC	3	O	0V(GND)	4		NC
1	I	RSTIN												
2		NC												
3	O	0V(GND)												
4		NC												
<p>&lt;Cable side connector type&gt;                  Connector : 51030-0430                  Contact : 50084-8160 x4                  Recommended manufacturer : MOLEX</p>														

**3.2.6 Emergency Stop Input Connector (EMGIN)**

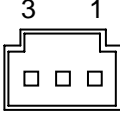
Name : EMGIN											
	<table border="1" style="border-collapse: collapse; text-align: center;"> <tr> <td style="width: 20px;">1</td> <td></td> <td>FG</td> </tr> <tr> <td>2</td> <td>I</td> <td>EMG IN</td> </tr> <tr> <td>3</td> <td>O</td> <td>+24V</td> </tr> </table>		1		FG	2	I	EMG IN	3	O	+24V
1		FG									
2	I	EMG IN									
3	O	+24V									
<p>&lt;Cable side connector type&gt;                  Connector : 51030-0330                  Contact : 50084-8160 x3                  Recommended manufacturer : MOLEX</p>											
<p>* Always connect the EMG terminating cable (G123) when not using this input.</p>											

3.2.7 Ethernet Connector (LAN)

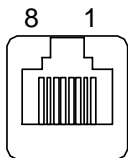
Name : LAN																										
	<table border="1" style="border-collapse: collapse; text-align: center;"> <tr><td>1</td><td>I</td><td>RD+</td></tr> <tr><td>2</td><td>I</td><td>RD+</td></tr> <tr><td>3</td><td>O</td><td>TD+</td></tr> <tr><td>4</td><td></td><td></td></tr> <tr><td>5</td><td></td><td></td></tr> <tr><td>6</td><td>O</td><td>TD-</td></tr> <tr><td>7</td><td></td><td></td></tr> <tr><td>8</td><td></td><td></td></tr> </table>	1	I	RD+	2	I	RD+	3	O	TD+	4			5			6	O	TD-	7			8			
1	I	RD+																								
2	I	RD+																								
3	O	TD+																								
4																										
5																										
6	O	TD-																								
7																										
8																										
<p>&lt;Cable side connector type&gt;                  Plug : 5-569550-3                  Recommended manufacturer : Tyco Electronics AMP</p>																										
<p>* Use a straight cable (G301) for connection with the display unit.</p>																										

3.2.8 24VDC Input Connector (DCIN)

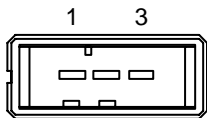
Name : DCIN											
	<table border="1" style="border-collapse: collapse; text-align: center;"> <tr><td>1</td><td>I</td><td>+24V</td></tr> <tr><td>2</td><td></td><td>0V</td></tr> <tr><td>3</td><td></td><td>FG</td></tr> </table>	1	I	+24V	2		0V	3		FG	
1	I	+24V									
2		0V									
3		FG									
<p>&lt;Cable side connector type&gt;                  Connector : 2-178288-3                  Contact : 1-175218-5 x3                  Recommended manufacturer : Tyco Electronics AMP</p>											

### 3.3 Connectors for Display Unit

#### 3.3.1 Ethernet Connector (LAN)

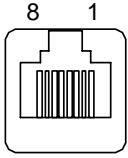
Name : LAN		
		
<p>&lt;Cable side connector type&gt;  Connector : 5-569550-3  Recommended manufacturer :  Tyco Electronics AMP</p>		
1	O	TD+
2	O	TD-
3	I	RD+
4		
5		
6	I	RD-
7		
8		
<p>* Use a straight cable (G301) for connection with the operation panel I/O unit.</p>		

#### 3.3.2 ON/OFF Switch Connector (ON/OFF)

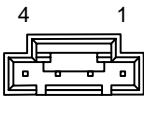
Name : ON/OFF		
		
<p>&lt;Cable side connector type&gt;  Connector : 51030-0430  Contact : 50084-8160 x4  Recommended manufacturer : MOLEX</p>		
1		0V
2	I	PON
3	I	POFF
4		0V

#### 3.3.3 USB Connector (USB1, USB2)

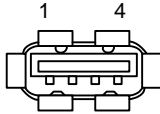
Name : USB1,USB2		
		
<p>&lt;Cable side connector type&gt;  Connector : DUSB-APA42-A-C50  Contact : DUSB-PA1-100 (When AWG20 to 24)  Recommended manufacturer : DDK</p>		
1	O	+5V
2	I/O	-DATA
3	I/O	+DATA
4		0V
<p>* Connect connector case with FG pattern.</p>		

3.3.4 Remote ON/OFF Connector (CF24)

Name : CF24

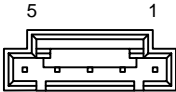

1		NC
2	I	P-OFF
3		0V
4		0V
5	I	P-ON

<Cable side connector type>  
 Connector : 51030-0530  
 Contact : 50084-8160 x4  
 Recommended manufacturer : MOLEX

\* Use this to connect the power supply unit (type: PD25/PD27) and display unit FCU7-DA315/DA415/DA445.

3.3.5 Emergency Stop Input Connector (EMGIN)

Name : EMGIN

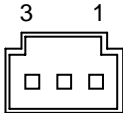

1		FG
2	I	EMG IN
3	O	+24V

<Cable side connector type>  
 Connector : 51030-0330  
 Contact : 50084-8160 x3  
 Recommended manufacturer : MOLEX

\* This connector is not used. Operation will not take place even if the EMG signal is input. Always connect an EMG terminating cable (G123) or leave this connector unconnected to prevent incorrect operations.

3.3.6 Power OFF Input Connector (CFO1)

Name : CFO1



1		0V
2	I	ACFAIL

<Cable side connector type>  
 Connector : 51030-0330  
 Contact : 50084-8160 x2  
 Recommended manufacturer : MOLEX

\* This connector is not used and must not be connected. Operation will not take place even if the ACFAIL signal is input.

3.3.7 24VDC Input Connector (DCIN)

Name : DCIN

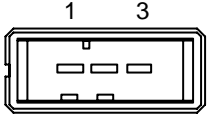

1	I	+24V
2		0V
3		FG

<Cable side connector type>  
 Connector : 2-178288-3  
 Contact : 1-175218-5 x3  
 Recommended manufacturer : Tyco Electronics AMP

3.3.8 Serial Communication Connector (SIOPC)

Name : SIOPC

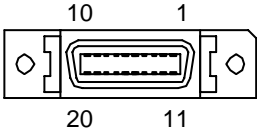

1		0V	11		0V
2	I	RD1(RXD1)	12	O	SD1(TXD1)
3	I	CS1(CTS1)	13	O	RS1(RTS1)
4	I	CD1(DCD1)	14	I	ER1(DTR1)
5		0V	15		0V
6	O	DR1(DSR1)	16	I	RI1(RI1)
7	I	RD2(RXD2)	17	O	SD2(TXD2)
8	I	CS2(CTS2)	18	O	RS2(RTS2)
9	I	CD2(DCD2)	19	I	ER2(DTR2)
10	O	DR2(DSR2)	20	I	RI2(RI2)

<Cable side connector type>  
 Plug : 10120-3000VE  
 Shell : 10320-52F0-008  
 Recommended manufacturer : 3M

\* Connect connector case with FG pattern.

### 3.4 Connectors for Power Supply Unit

#### 3.4.1 24VDC Output Connector (DCOUT)

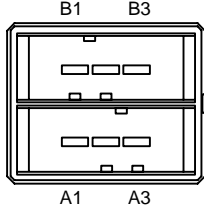
Name : DCOUT																							
			<table border="1"> <tr> <td>1A</td> <td>O</td> <td>ACFAIL</td> <td>1B</td> <td>O</td> <td>+24V</td> </tr> <tr> <td>2A</td> <td></td> <td>0V</td> <td>2B</td> <td></td> <td>0V</td> </tr> <tr> <td>3A</td> <td></td> <td>NC</td> <td>3B</td> <td></td> <td>FG</td> </tr> </table>			1A	O	ACFAIL	1B	O	+24V	2A		0V	2B		0V	3A		NC	3B		FG
1A	O	ACFAIL	1B	O	+24V																		
2A		0V	2B		0V																		
3A		NC	3B		FG																		
<Cable side connector type>																							
Connector : 3-178127-6																							
Contact : 1-175218-5 (for AWG16) x3																							
: 1-175217-5 (for AWG22) x2																							
Recommended manufacturer : Tyco Electronics AMP																							

#### 3.4.2 AC Power Input Connector (ACIN)

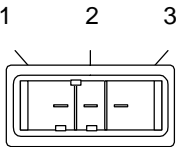
Name : ACIN											
		<table border="1"> <tr> <td>1</td> <td>I</td> <td>ACIN N</td> </tr> <tr> <td>2</td> <td>I</td> <td>ACIN H</td> </tr> <tr> <td>3</td> <td></td> <td>FG</td> </tr> </table>	1	I	ACIN N	2	I	ACIN H	3		FG
1	I	ACIN N									
2	I	ACIN H									
3		FG									
<Cable side connector type>											
Connector : 2-178128-3											
Contact : 1-175218-5 x3											
Recommended manufacturer : Tyco Electronics AMP											

#### 3.4.3 ON/OFF Input Connector (ON/OFF)

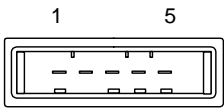
Name : ON/OFF																	
		<table border="1"> <tr> <td>1</td> <td></td> <td>NC</td> </tr> <tr> <td>2</td> <td>I</td> <td>P-OFF</td> </tr> <tr> <td>3</td> <td></td> <td>0V</td> </tr> <tr> <td>4</td> <td></td> <td>0V</td> </tr> <tr> <td>5</td> <td>I</td> <td>P-ON</td> </tr> </table>	1		NC	2	I	P-OFF	3		0V	4		0V	5	I	P-ON
1		NC															
2	I	P-OFF															
3		0V															
4		0V															
5	I	P-ON															
<Cable side connector type>																	
Connector : 1-178288-5																	
Contact : 1-175218-5 x4																	
Recommended manufacturer : Tyco Electronics AMP																	

## Appendix 4. Servo/Spindle Cable and Connector Specifications (MDS-D/DH Series)

### 4.1 Selection of Cable

#### 4.1.1 Cable Wire and Assembly

##### (1) Cable wire

The specifications of the wire used for each cable, and the machining methods are shown in this section. When manufacturing the detector cable and battery connection cable, use the recommended wires shown below or equivalent products.

##### (a) Heat resistant specifications cable

Wire type (special order part)	Finish outer diameter	Sheath material	No. of pairs	Wire characteristics					
				Configuration	Conductive resistor	Withstand voltage	Insulation resistance	Heat resistance temperature	Flexibility
BD20288 Compound 6-pair shielded cable Specification No. Bangishi-17145 (Note 1)	8.7mm	Heat resistant PVC	2 (0.5mm <sup>2</sup> )	100 strands/ 0.08mm	40.7Ω/km or less	500VAC/ 1min	1000MΩ/km or more	105°C	70×10 <sup>4</sup> times or more at R200
			4 (0.2mm <sup>2</sup> )	40 strands/ 0.08mm	103Ω/km or less				

##### (b) General-purpose heat resistant specifications cable

Wire type (special order part)	Finish outer diameter	Sheath material	No. of pairs	Wire characteristics					
				Configuration	Conductive resistor	Withstand voltage	Insulation resistance	Heat resistance temperature	Flexibility
BD20032 Compound 6-pair shielded cable Specification No. Bangishi-16903 Revision No. 3 (Note 2)	8.7mm	PVC	2 (0.5mm <sup>2</sup> )	100 strands/ 0.08mm	40.7Ω/km or less	500VAC/ 1min	1000MΩ/km or more	60°C	100×10 <sup>4</sup> times or more at R200
			4 (0.2mm <sup>2</sup> )	40 strands/ 0.08mm	103Ω/km or less				

(Note 1) Bando Electric Wire (Contact: 81+48-461-0561 <http://www.bew.co.jp>)

(Note 2) The Mitsubishi standard cable is the (a) Heat resistant specifications cable. For MDS-C1/CH series, (b) or equivalent is used as the standard cable.

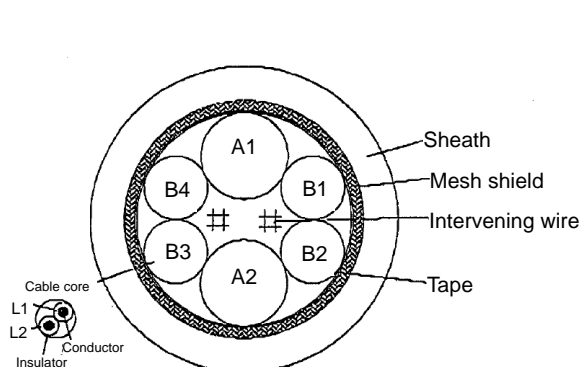

Compound 6-pair cable structure drawing

Core identification

Pair No.	Insulator color	
	L1	L2
A1 (0.5mm <sup>2</sup> )	Red	White
A2 (0.5mm <sup>2</sup> )	Black	White
B1 (0.2mm <sup>2</sup> )	Brown	Orange
B2 (0.2mm <sup>2</sup> )	Blue	Green
B3 (0.2mm <sup>2</sup> )	Purple	White
B4 (0.2mm <sup>2</sup> )	Yellow	White

**(2) Cable assembly**

Assemble the cable with the cable shield wire securely connected to the ground plate of the connector.

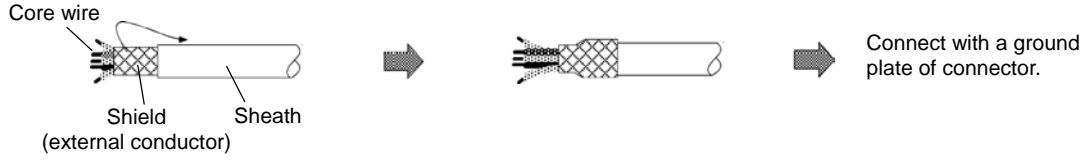

**(3) Battery connection cable**

Wire type (special order part)	Finish outer diameter	Sheath material	No. of pairs	Wire characteristics					
				Configuration	Conductiv e resistor	Withstand voltage	Insulation resistance	Heat resistance temperature	Minimum bend radius
J14B101224-00 Two core shield cable	3.3mm	PVC	1 (0.2mm <sup>2</sup> )	7 strands / 0.2mm	91.2Ω/km or less	AC500V/1min	1000MΩ /km or more	80°C	R33mm

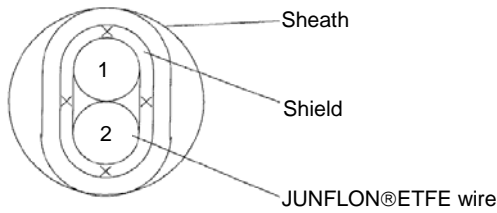

Two core shield cable structure drawing

**Core identification**

No.	Insulator color
1	Red
2	Black



4.2 Cable Connection Diagram

 <b>CAUTION</b>	1. Take care not to mistake the connection when manufacturing the detector cable. Failure to observe this could lead to faults, runaway or fire.
	2. When manufacturing the cable, do not connect anything to pins which have no description.

4.2.1 Battery Cable

<DG21 cable connection diagram>

(Connection cable between drive unit and MDS-A-BT/MR-BAT (MDS-BTCASE))

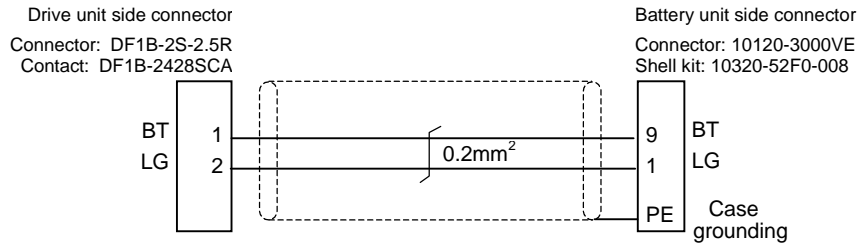

<Cable connection diagram between drive unit and FCU6-BTBOX-36>

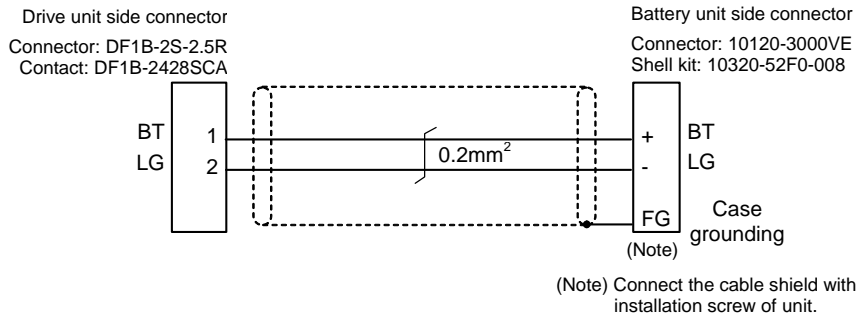

<DG22 cable connection diagram>

(Connection cable between drive unit and drive unit)

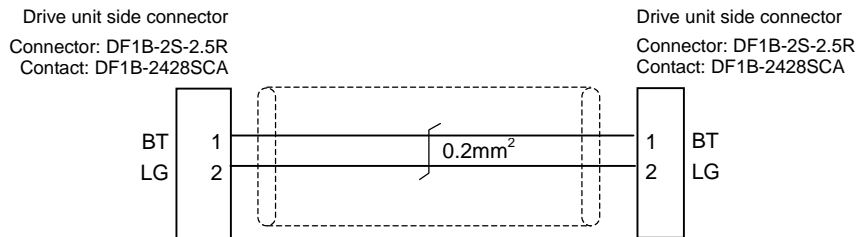

4.2.2 Power Supply Communication Cable and Connector

<SH21 cable connection diagram>

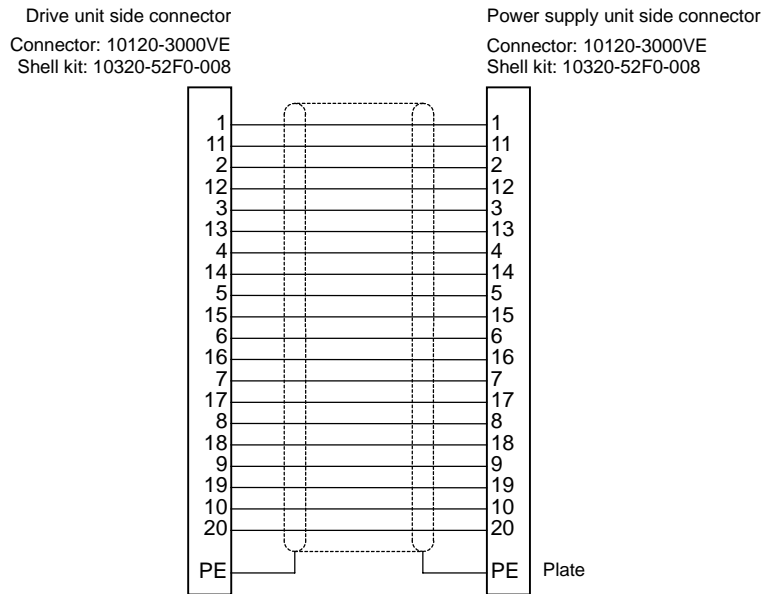

<CNU23S connector connection diagram>

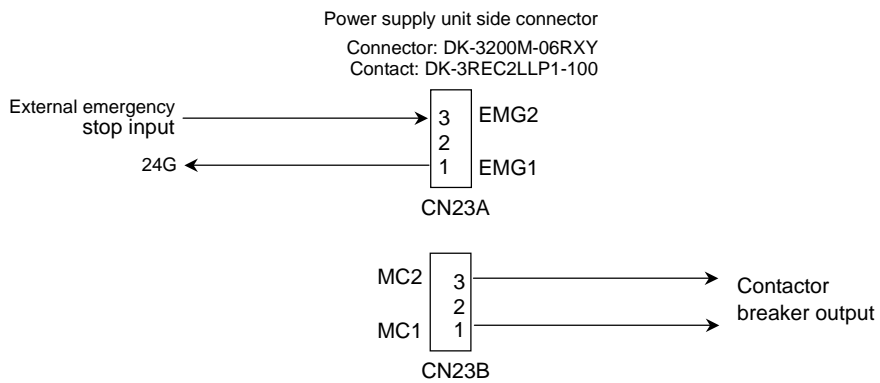

4.2.3 Servo Detector Cable

<CNV2E-6P, CNV2E-7P cable connection diagram>

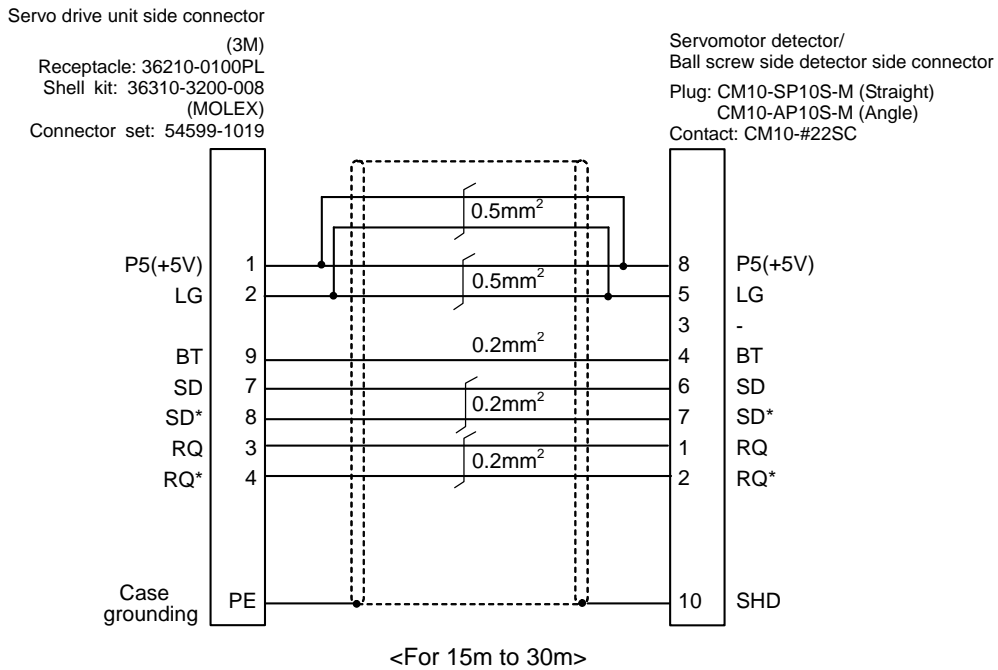
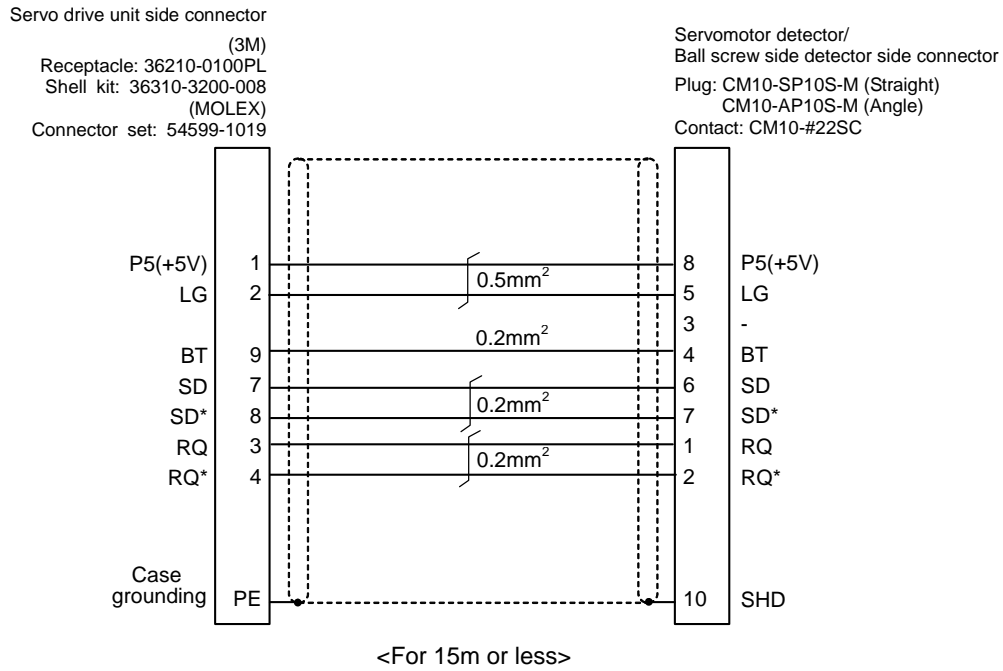

<CNV2E-HP cable connection diagram>

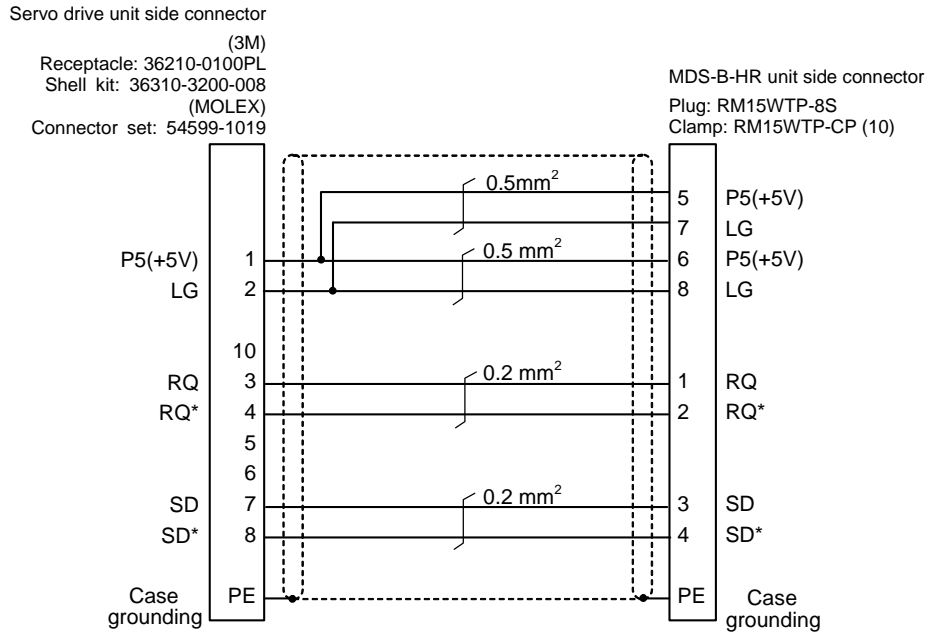

<CNV2E-D cable connection diagram>

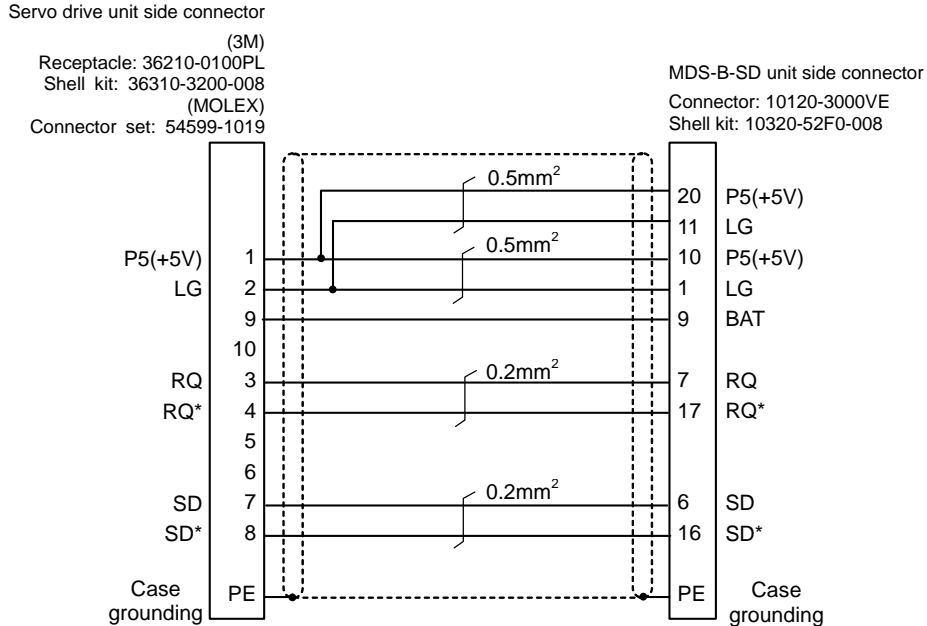

<Cable connection diagram between scale I/F unit and scale (CNLH3 cable, etc.)>

Detector conversion unit side connector  
 Plug: RM15WTP-12P  
 Clamp: RM15WTP-CP (10)

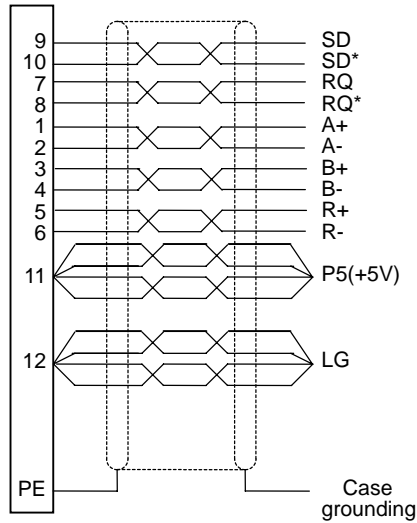

(Note) This cable must be prepared by the user.

<Oblong wave communication detector (linear scale, etc.) cable connection diagram>

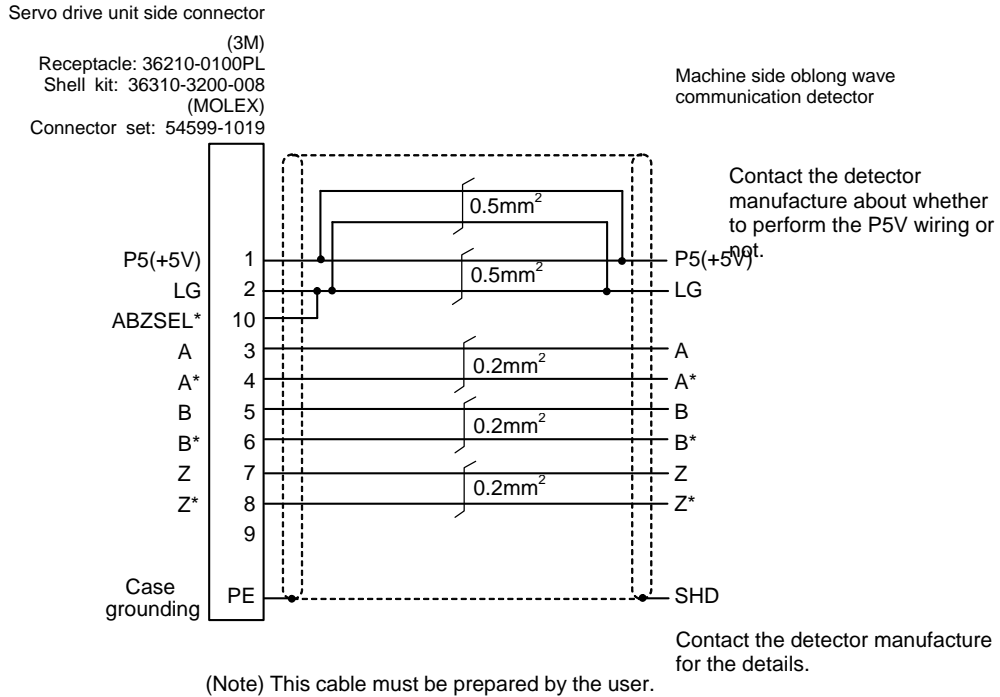

<Serial communication detector (linear scale, etc.) cable connection diagram>

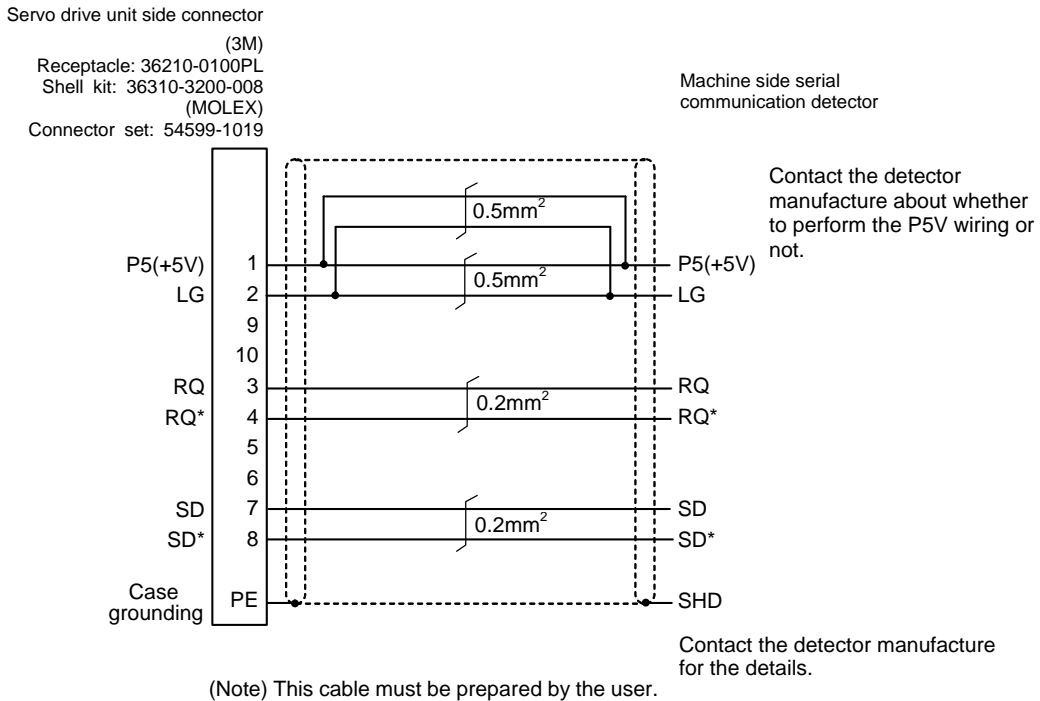

**POINT**

For compatible detector, refer to the section "4-1 Servo option" in MDS-D/DH series Specifications Manual.

4.2.4 Brake Connector (Brake Connector for Motor Brake Control Output)

<CN20S connector connection diagram>

- For MDS-D-V1-320 or smaller and MDS-DH-V1-160 or smaller

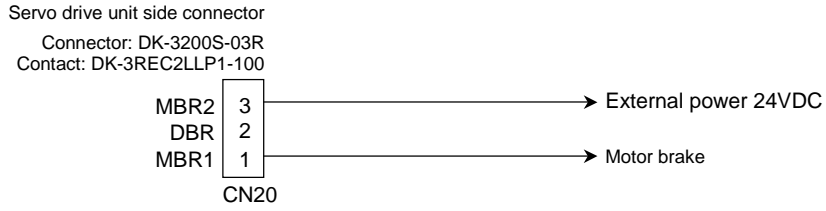

- For MDS-D-V1-320W or larger and MDS-DH-V1-160W or larger

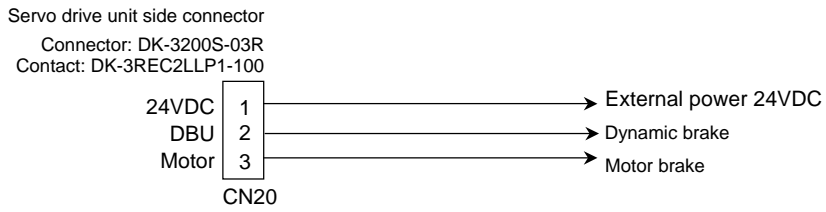

4.2.5 Spindle Detector Cable

<CNP2E-1 cable connection diagram>

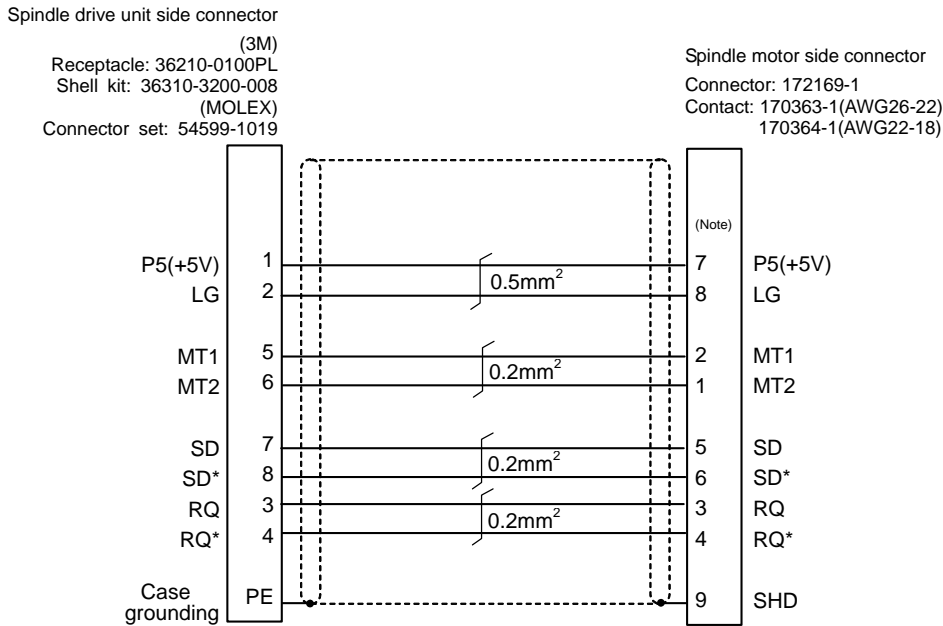

(Note) For the pin "7" or "8", use the contact "170364-1".  
For the other pins, use the contact "170363-1".  
<For 15m or less>

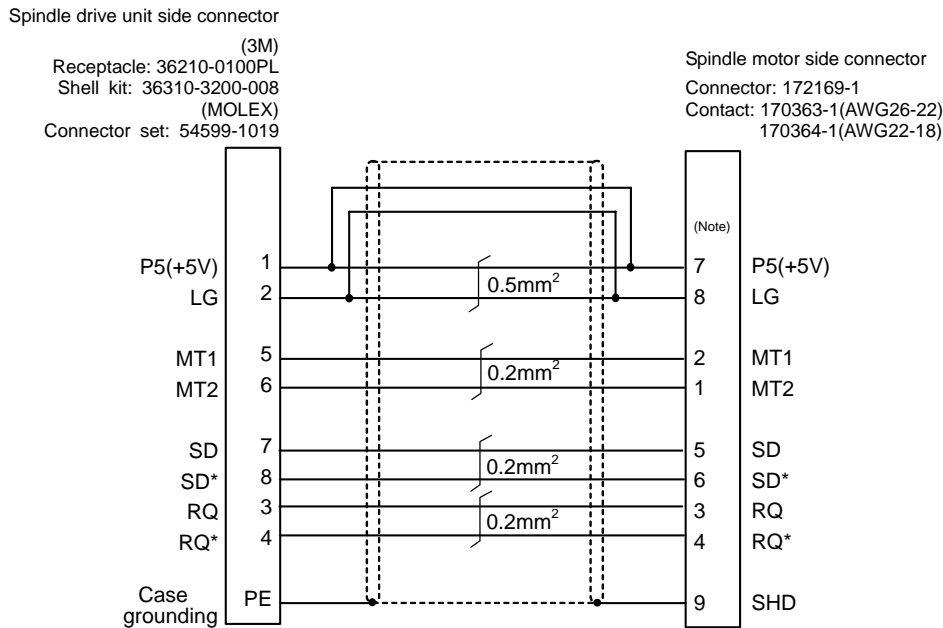

(Note) For the pin "7" or "8", use the contact "170364-1".  
For the other pins, use the contact "170363-1".  
<For 15m to 30m>



<CNP3EZ-2P, CNP3EZ-3P cable connection diagram>

Spindle drive unit side connector  
 (3M)  
 Receptacle: 36210-0100PL  
 Shell kit: 36310-3200-008  
 (MOLEX)  
 Connector set: 54599-1019

Spindle motor side connector  
 Connector: MS3106A20-29S(D190)  
 Back shell: CE02-20BS-S (straight)  
 CE-20BA-S (angle)  
 Clamp: CE3057-12A-3

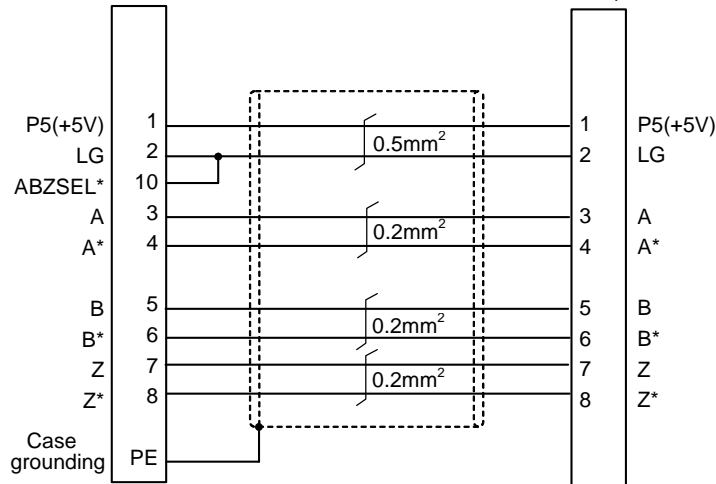

<For 15m or less>

Spindle drive unit side connector  
 (3M)  
 Receptacle: 36210-0100PL  
 Shell kit: 36310-3200-008  
 (MOLEX)  
 Connector set: 54599-1019

Spindle motor side connector  
 Connector: MS3106A20-29S(D190)  
 Back shell: CE02-20BS-S (straight)  
 CE-20BA-S (angle)  
 Clamp: CE3057-12A-3

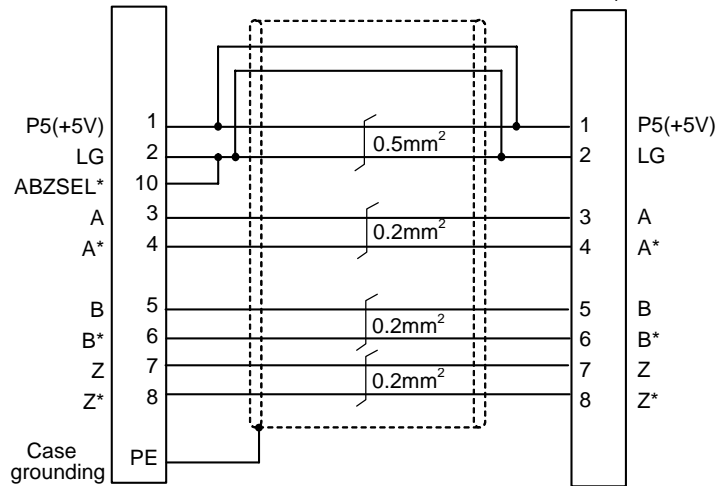

<For 15m to 30m>

4.2.6 C axis Detector Cable (For Serial Interface Conversion Unit APE391M Connection)

<Serial communication detector cable connection diagram>

Spindle drive unit side connector

(3M)

Receptacle: 36210-0100PL

Shell kit: 36310-3200-008

(MOLEX)

Connector set: 54599-1019

APE391M side connector

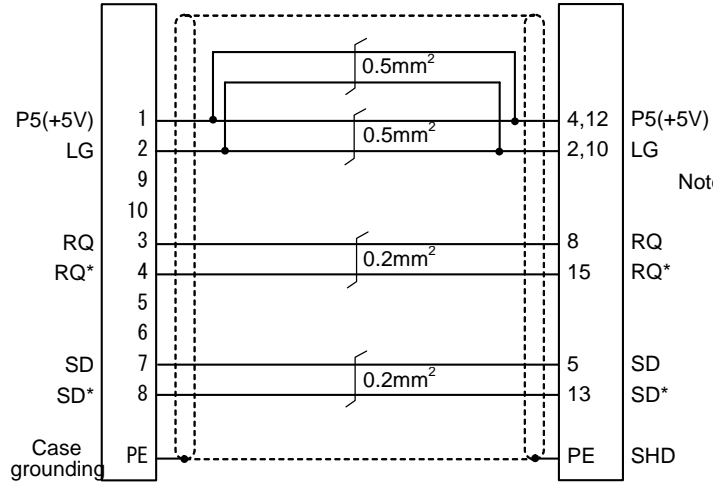

Note: Check with the manufacturer of the detector to be connected whether to do P5V wiring.

Contact the detector manufacturer.

(Note) The cable must be prepared by the user.

### 4.3 Main Circuit Cable Connection Diagram

The methods for wiring to the main circuit are shown below.

#### 4.3.1 DRSV1 cable, DRSV2 cable

These cables are used to connect the servo drive unit's TE1 terminal and HF(-H) / HP(-H) motor.

- DRSV1 cable: This is the power line for the single-axis unit (MDS-D/DH-V1-) and dual-axis integrated unit (MDS-D/DH-V2-) L axis.
- DRSV2 cable: This is the power line for the dual-axis integrated unit (MDS-D/DH-V2-) M axis.

<DRSV1/DRSV2 cable connection diagram>

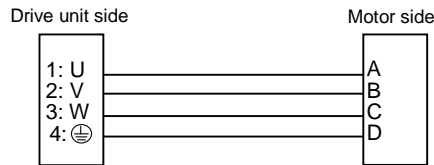

#### CAUTION

1. The main circuit cable must be manufactured by the user.
2. Refer to the section "5. Selection of peripheral devices" in MDS-D/DH Series Specifications Manual when selecting the wire material.
3. Lay out the terminal block on the drive unit side as shown in "Appendix 1. Outline dimension drawing" in MDS-D/DH Series Specifications Manual.
4. Refer to "Appendix 1-1 Servomotor outline dimension drawings" in MDS-D/DH Series Specifications Manual for details on the servomotor's connectors and terminal block.

### 4.4 Connector Outline Dimension Drawings

#### 4.4.1 Optical Communication Cable

##### (1) For wiring between drive units (inside panel)

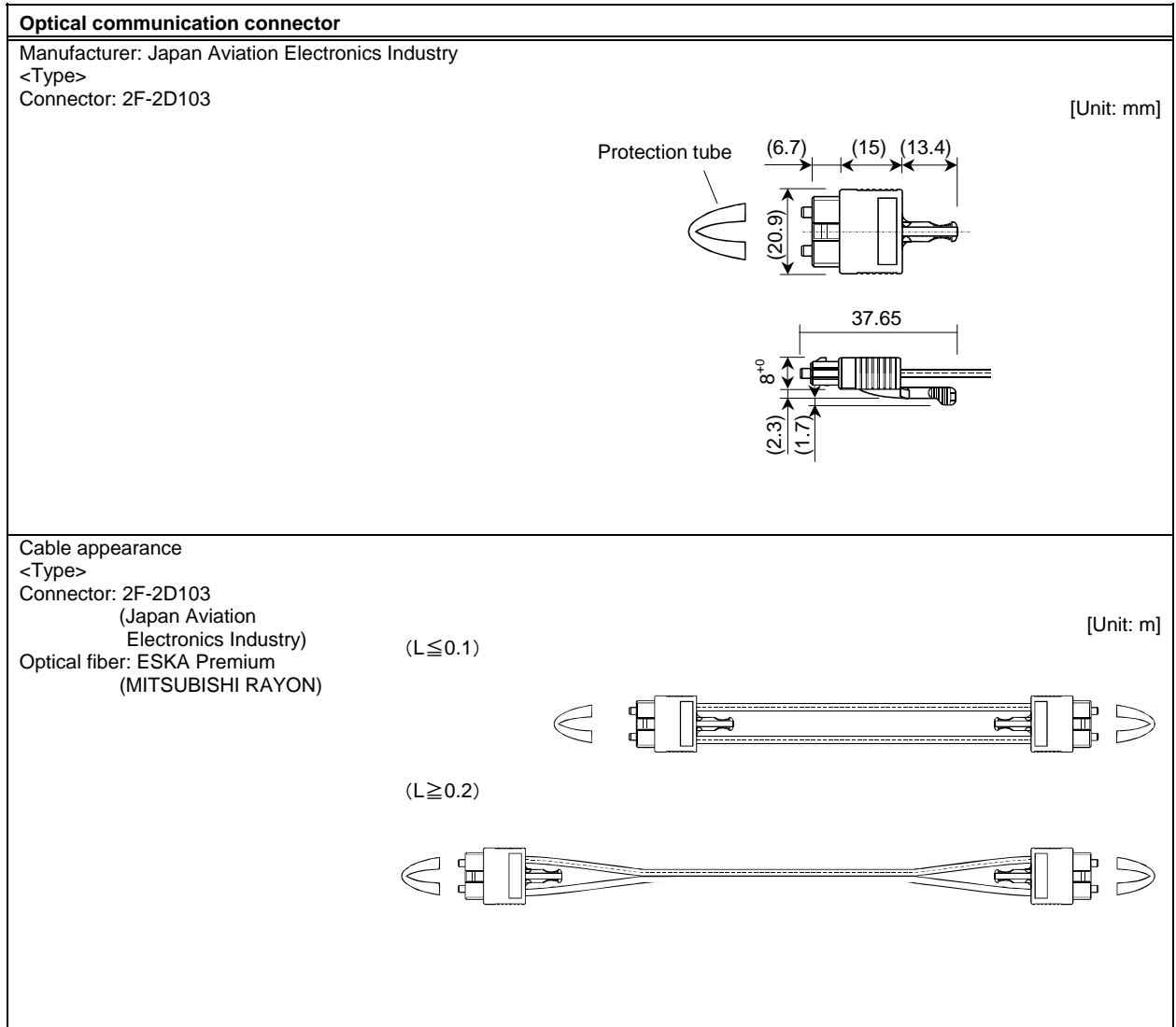

**(Note 1)** The POF fiber's light amount will drop depending on how the fibers are wound. So, try to avoid wiring the fibers.

**(Note 2)** Do not wire the optical fiber cable to moving sections.

(2) For wiring between drive units (outside panel)

Optical communication connector	
Manufacturer: Tyco Electronics AMP <Type> Connector: 1123445-1	[Unit: mm]
Cable appearance <Type> Connector: 1123445-1 (Tyco Electronics AMP) Optical fiber: ESKA Premium (MITSUBISHI RAYON)	

- (Note 1)** The PCF fiber's light amount will drop depending on how the fibers are wound. So, try to avoid wiring the fibers.  
**(Note 2)** Do not wire the optical fiber cable to moving sections.

**Appendix 4. Servo/Spindle Cable and Connector Specifications (MDS-D/DH)**  
**4.4 Connector Outline Dimension Drawings**

**4.4.2 Battery Connector**

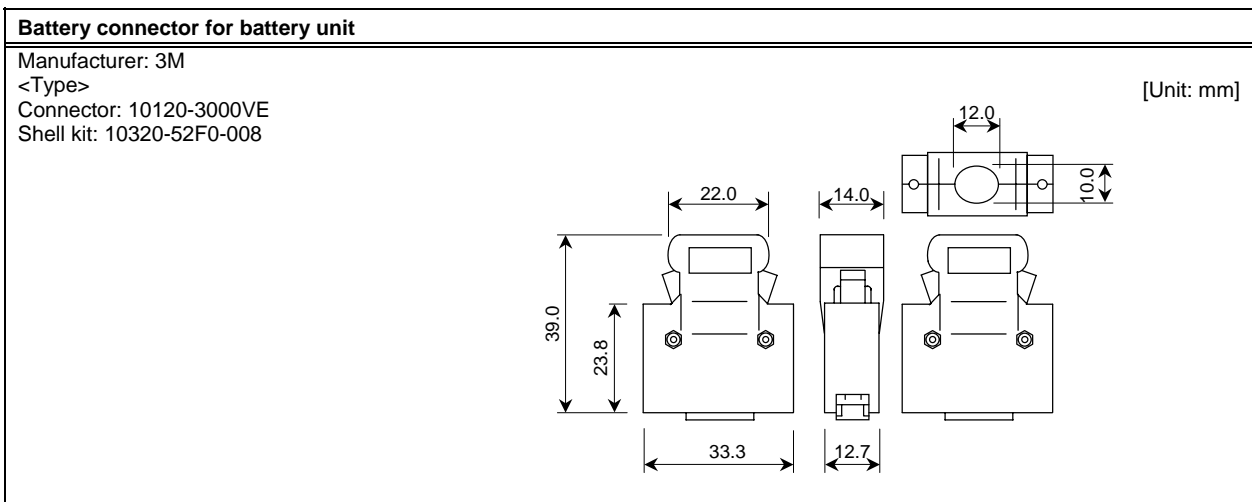
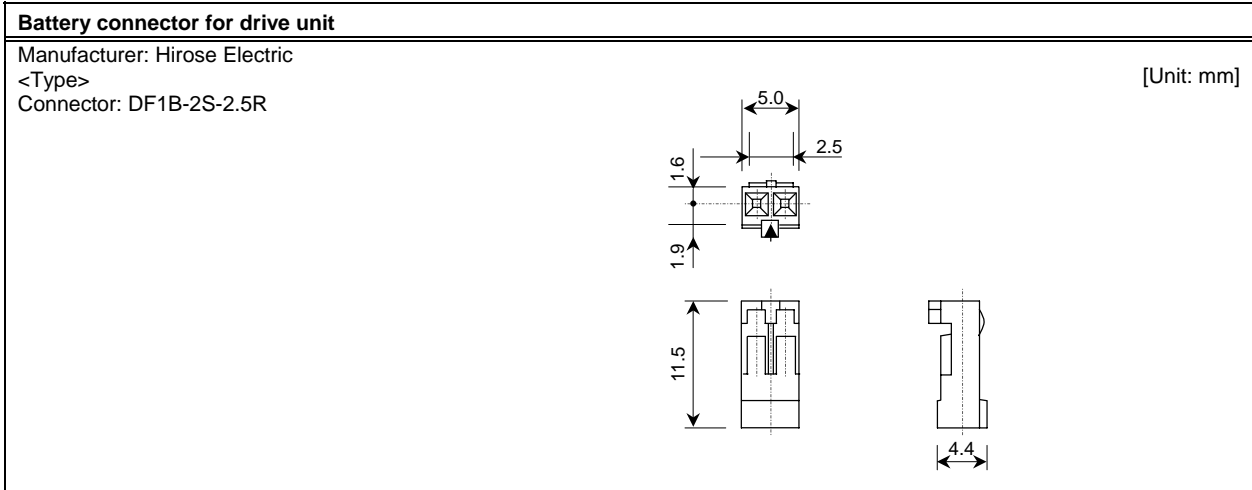

**Appendix 4. Servo/Spindle Cable and Connector Specifications (MDS-D/DH)**  
**4.4 Connector Outline Dimension Drawings**

**4.4.3 Power Supply Communication Connector**

<p><b>Power supply unit connector for CN4/9</b></p> <p>Manufacturer: 3M                  &lt;Type&gt;                  Connector: 10120-3000VE                  Shell kit: 10320-52F0-008</p>	<p>[Unit: mm]</p>
<p>Manufacturer: 3M                  &lt;Type&gt;                  Connector: 10120-6000EL                  Shell kit: 10320-3210-000</p> <p>This connector is integrated with the cable, and is not available as a connector set option.</p>	<p>[Unit: mm]</p>

<p><b>Power supply unit connector for CN23 (Connector for contactor control output / external emergency stop)</b></p> <p>Manufacturer: DDK                  &lt;Type&gt;                  Connector: DK-3200M-06RXY</p>	<p>[Unit: mm]</p>

**Appendix 4. Servo/Spindle Cable and Connector Specifications (MDS-D/DH)**  
**4.4 Connector Outline Dimension Drawings**

**4.4.4 Servo Detector Connector**

<b>Motor side detector connector / Ball screw side detector for connector</b>	
Manufacturer: DDK <Type> Plug: CM10-SP10S-M	<div style="text-align: right;">[Unit: mm]</div> <div style="text-align: center; margin-top: 20px;"> </div>
Manufacturer: DDK <Type> Plug: CM10-AP10S-M	<div style="text-align: right;">[Unit: mm]</div> <div style="text-align: center; margin-top: 20px;"> </div>

**(Note)** For the manufacturing method of CM10 series connector, refer to the section "Cable and connector assembly" in MDS-D/DH Instruction Manual.



**Appendix 4. Servo/Spindle Cable and Connector Specifications (MDS-D/DH)**  
**4.4 Connector Outline Dimension Drawings**

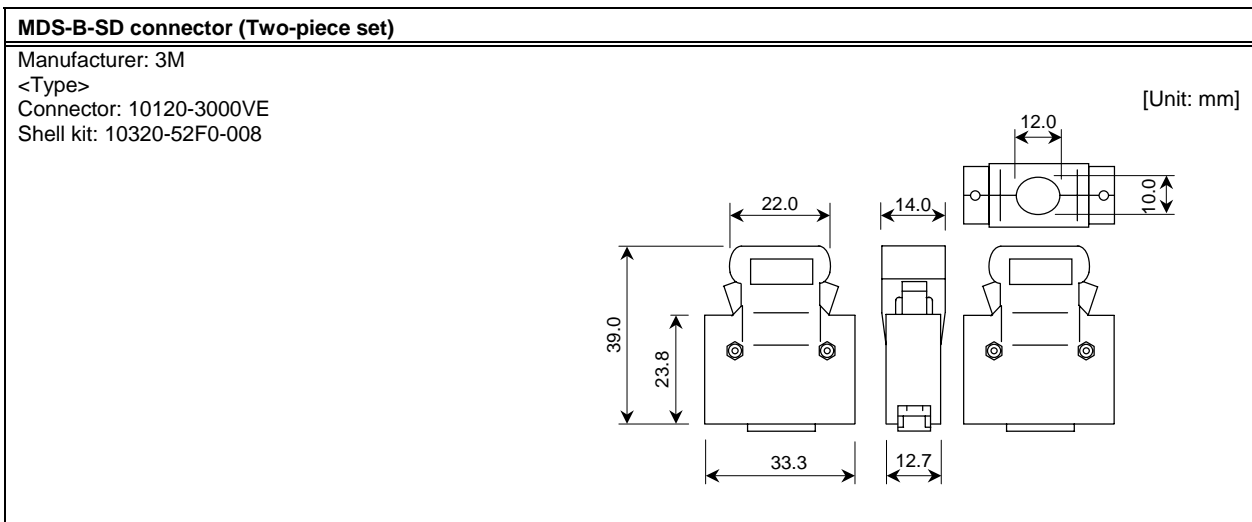
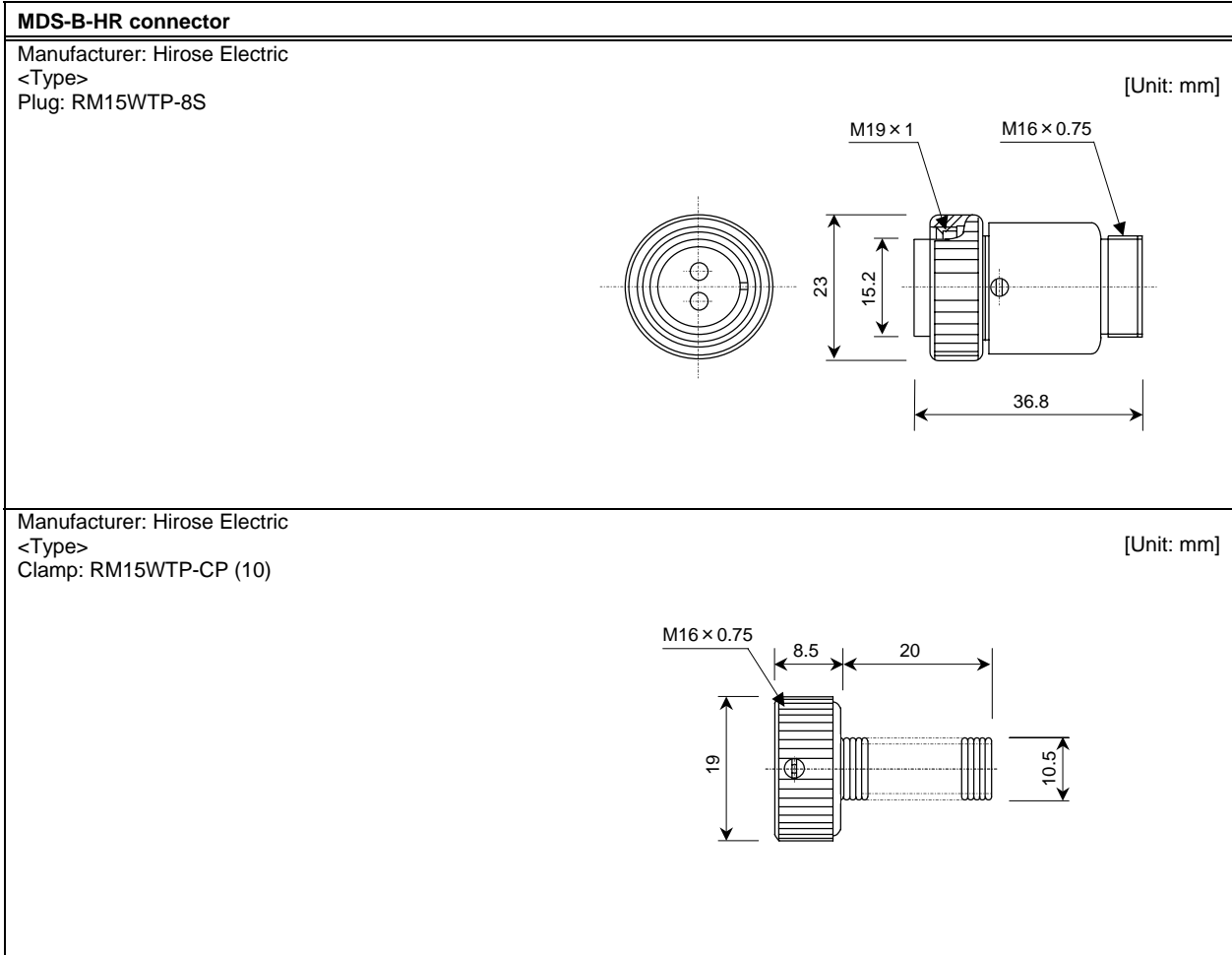

**Appendix 4. Servo/Spindle Cable and Connector Specifications (MDS-D/DH)**  
**4.4 Connector Outline Dimension Drawings**

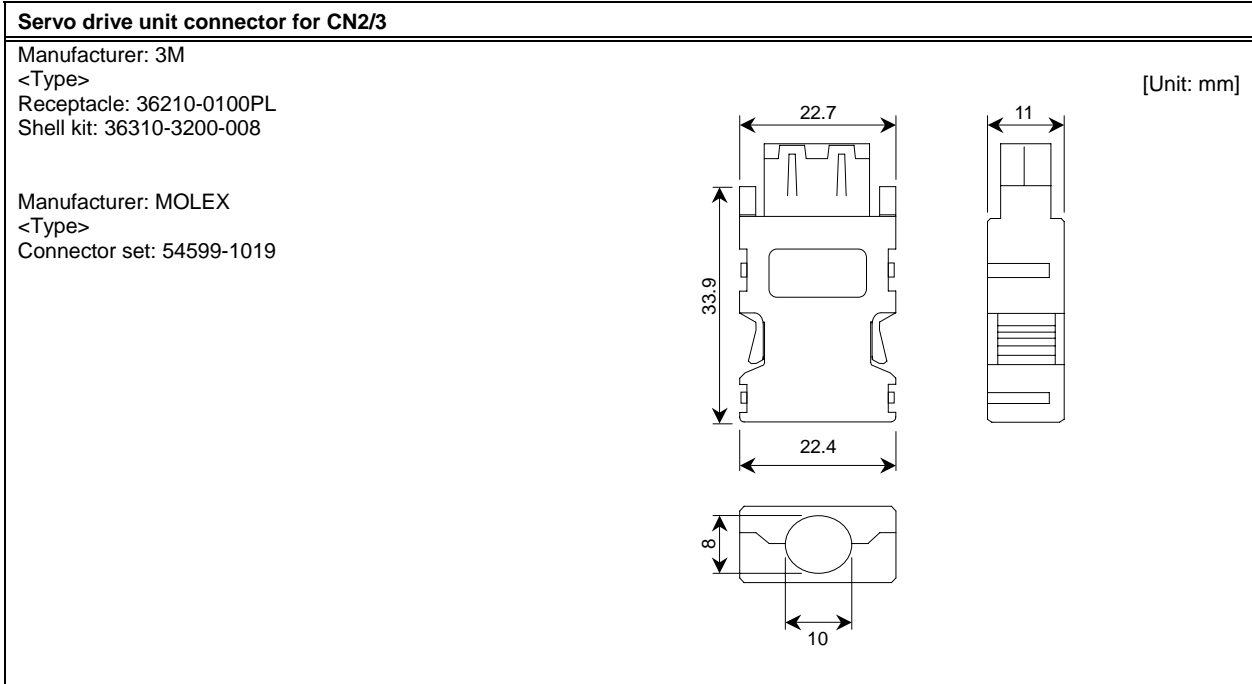

**Appendix 4. Servo/Spindle Cable and Connector Specifications (MDS-D/DH)**  
**4.4 Connector Outline Dimension Drawings**

**4.4.5 Brake Connector**

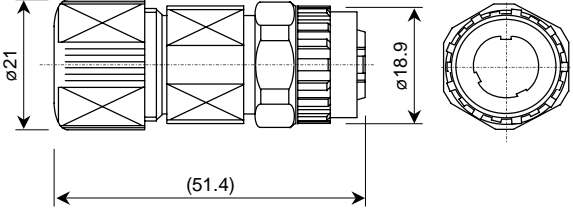
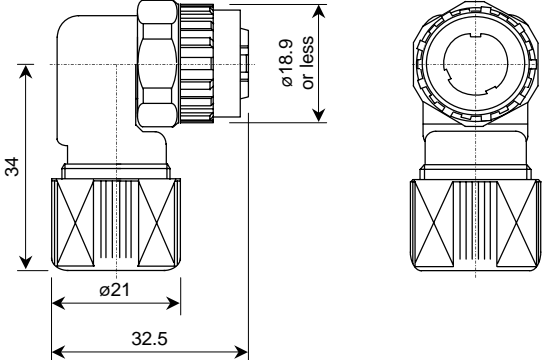
<p><b>Brake connector for HF, HP</b>          Manufacturer: DDK          &lt;Type&gt;          Plug: CM10-SP2S-S</p> <p align="right">[Unit: mm]</p> 
<p>Manufacturer: DDK          &lt;Type&gt;          Plug: CM10-AP2S-S</p> <p align="right">[Unit: mm]</p> 

**(Note)** For the manufacturing method of CM10 series connector, refer to the section "Cable and connector assembly" in MDS-D/DH Instruction Manual.

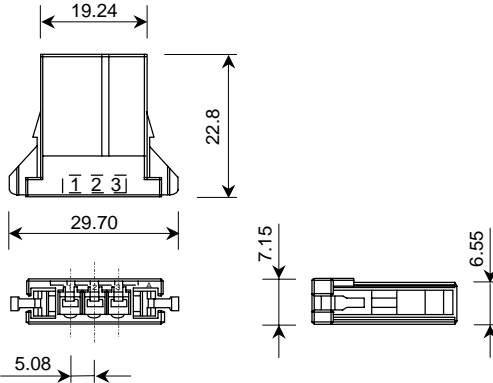
<p><b>Brake connector for motor brake control output</b>          Manufacturer: DDK          &lt;Type&gt;          Connector: DK-3200S-03R</p> <p align="right">[Unit: mm]</p> 
---

**Appendix 4. Servo/Spindle Cable and Connector Specifications (MDS-D/DH)**  
**4.4 Connector Outline Dimension Drawings**

**4.4.6 Power Connector**

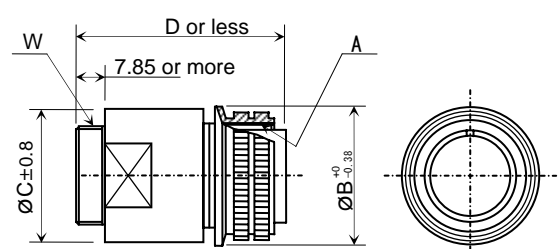
<b>Motor power connector</b>											
Manufacturer: DDK											
											
Plug:						[Unit: mm]					
Type	A	B <sup>+0</sup> <sub>-0.38</sub>	C±0.8	D or less	W						
CE05-6A18-10SD-C-BSS	1 <sup>1</sup> / <sub>8</sub> -18UNEF-2B	34.13	32.1	57	1-20UNEF-2A						
CE05-6A22-22SD-C-BSS	1 <sup>3</sup> / <sub>8</sub> -18UNEF-2B	40.48	38.3	61	1 <sup>3</sup> / <sub>16</sub> -18UNEF-2A						
CE05-6A32-17SD-C-BSS	2-18UNS-2B	56.33	54.2	79	1 <sup>3</sup> / <sub>4</sub> -18UNS-2A						

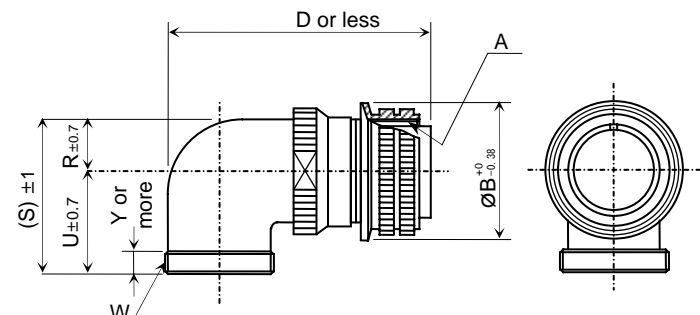

Manufacturer: DDK											
											
Plug:						[Unit: mm]					
Type	A	B <sup>+0</sup> <sub>-0.38</sub>	D or less	W	R±0.7	U±0.7	(S)±1	Y or more			
CE05-8A18-10SD-C-BAS	1 <sup>1</sup> / <sub>8</sub> -18UNEF-2B	34.13	69.5	1-20UNEF-2A	13.2	30.2	43.4	7.5			
CE05-8A22-22SD-C-BAS	1 <sup>3</sup> / <sub>8</sub> -18UNEF-2B	40.48	75.5	1 <sup>3</sup> / <sub>16</sub> -18UNEF-2A	16.3	33.3	49.6	7.5			
CE05-8A32-17SD-C-BAS	2-18UNS-2B	56.33	93.5	1 <sup>3</sup> / <sub>4</sub> -18UNS-2A	24.6	44.5	61.9	8.5			

Manufacturer: DDK												
												
Clamp:						[Unit: mm]						
Type	Shell size	Total length	Outer dia.	Avail. screw length	D	E	F	G	H	Fitting screw V	Bushing	Applicable cable
CE3057-10A-1(D240)	18	23.8	30.1	10.3	41.3	15.9	14.1	31.7	3.2	1-20UNEF-2B	CE3420-10-1	φ10.5~φ14.1
CE3057-12A-1(D240)	20	23.8	35	10.3	41.3	19	16.0	37.3	4	1 <sup>3</sup> / <sub>16</sub> -18UNEF-2B	CE3420-12-1	φ12.5~φ16.0
CE3057-20A-1(D240)	32	27.8	51.6	11.9	43	31.7	23.8	51.6	6.3	1 <sup>3</sup> / <sub>4</sub> -18UNS-2B	CE3420-20-1	φ22.0~φ23.8

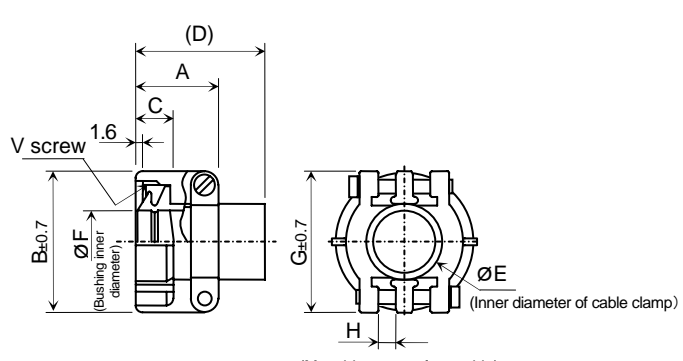
**Appendix 4. Servo/Spindle Cable and Connector Specifications (MDS-D/DH)**  
**4.4 Connector Outline Dimension Drawings**

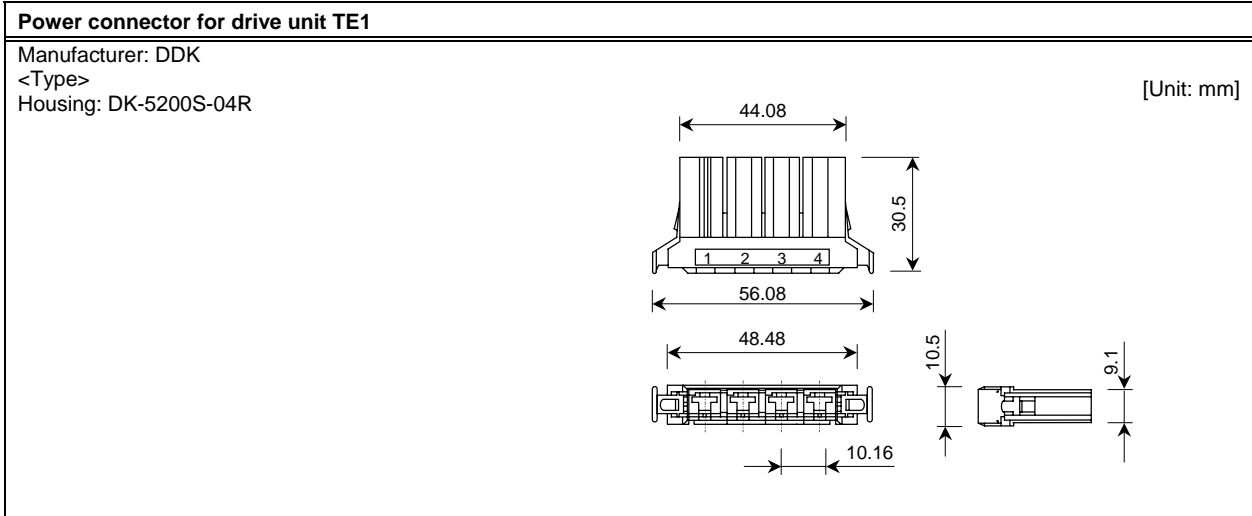

**Appendix 4. Servo/Spindle Cable and Connector Specifications (MDS-D/DH)**  
**4.4 Connector Outline Dimension Drawings**

**4.4.7 Spindle Detector Connector**

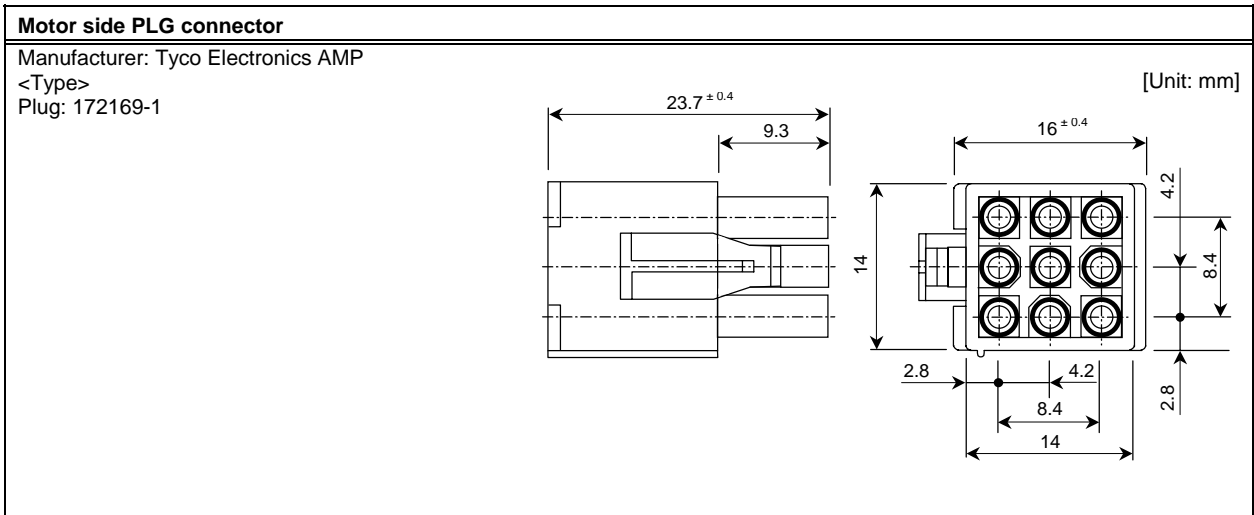
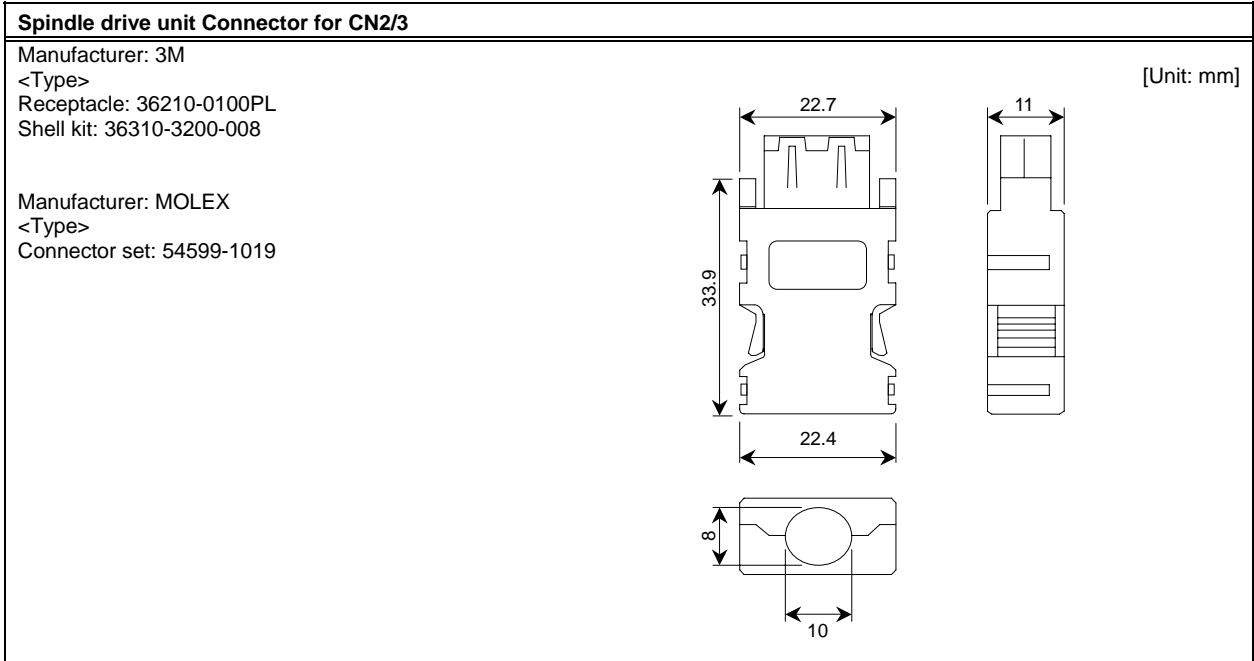

**Appendix 4. Servo/Spindle Cable and Connector Specifications (MDS-D/DH)**  
**4.4 Connector Outline Dimension Drawings**

<p><b>Spindle side detector connector (for OSA1024)</b></p>	<p>Manufacturer: DDK                  &lt;Type&gt;                  Connector: MS3106A20-29S (D190) [Unit: mm]</p>
<p>Manufacturer: DDK                  &lt;Type&gt;                  Straight back shell: CE02-20BS-S</p>	<p>[Unit: mm]</p>
<p>Manufacturer: DDK                  &lt;Type&gt;                  Angle back shell: CE-20BA-S</p>	<p>[Unit: mm]</p>
<p>Manufacturer: DDK                  &lt;Type&gt;                  Cable clamp: CE3057-12A-3</p>	<p>[Unit: mm]</p>

## Appendix 5. Servo/Spindle Cable and Connector Specifications (MDS-D-SVJ3/SPJ3 Series)

### 5.1 Selection of Cable

#### 5.1.1 Cable Wire and Assembly

##### (1) Cable wire

The specifications of the wire used for each cable, and the machining methods are shown in this section. When manufacturing the detector cable and battery connection cable, use the recommended wires shown below or equivalent products.

##### (a) Heat resistant specifications cable

Wire type (special order part)	Finish outer diameter	Sheath material	No. of pairs	Wire characteristics					
				Configura-tion	Conductive resistor	Withstand voltage	Insulation resistance	Heat resistance temperature	Flexibility
BD20288 Compound 6-pair shielded cable Specification No. Bangishi-17145 (Note 1)	8.7mm	Heat resistant PVC	2 (0.5mm <sup>2</sup> )	100 strands/0.08mm	40.7Ω/km or less	500VAC/1min	1000MΩ/km or more	105°C	70×10 <sup>4</sup> times or more at R200
			4 (0.2mm <sup>2</sup> )	40 strands/0.08mm	103Ω/km or less				

##### (b) General-purpose heat resistant specifications cable

Wire type (special order part)	Finish outer diameter	Sheath material	No. of pairs	Wire characteristics					
				Configura-tion	Conductive resistor	Withstand voltage	Insulation resistance	Heat resistance temperature	Flexibility
BD20032 Compound 6-pair shielded cable Specification No. Bangishi-16903 Revision No. 3 (Note 2)	8.7mm	PVC	2 (0.5mm <sup>2</sup> )	100 strands/0.08mm	40.7Ω/km or less	500VAC/1min	1000MΩ/km or more	60°C	100×10 <sup>4</sup> times or more at R200
			4 (0.2mm <sup>2</sup> )	40 strands/0.08mm	103Ω/km or less				

(Note 1) Bando Electric Wire (Contact: 81+48-461-0561 <http://www.bew.co.jp>)

(Note 2) The Mitsubishi standard cable is the (a) Heat resistant specifications cable. For MDS-C1/CH series, (b) or equivalent is used as the standard cable.

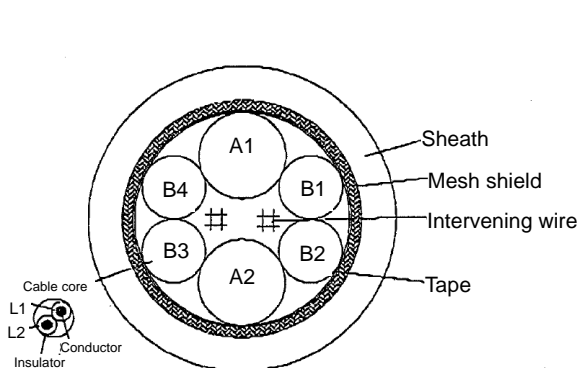

Compound 6-pair cable structure drawing

#### Core identification

Pair No.	Insulator color	
	L1	L2
A1 (0.5mm <sup>2</sup> )	Red	White
A2 (0.5mm <sup>2</sup> )	Black	White
B1 (0.2mm <sup>2</sup> )	Brown	Orange
B2 (0.2mm <sup>2</sup> )	Blue	Green
B3 (0.2mm <sup>2</sup> )	Purple	White
B4 (0.2mm <sup>2</sup> )	Yellow	White



**(2) Cable assembly**

Assemble the cable with the cable shield wire securely connected to the ground plate of the connector.

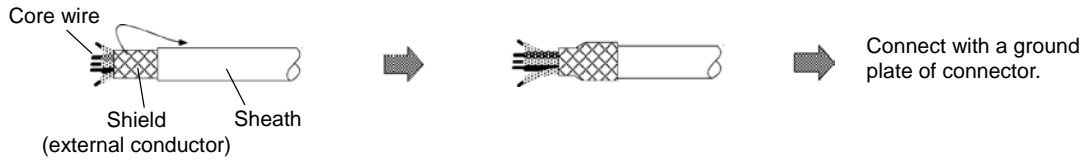

## 5.2 Cable Connection Diagram

 <b>CAUTION</b>	1. Take care not to mistake the connection when manufacturing the detector cable. Failure to observe this could lead to faults, runaway or fire.
	2. When manufacturing the cable, do not connect anything to pins which have no description.

### 5.2.1 Servo Detector Cable

<CNV2E-8P, CNV2E-9P cable connection diagram>

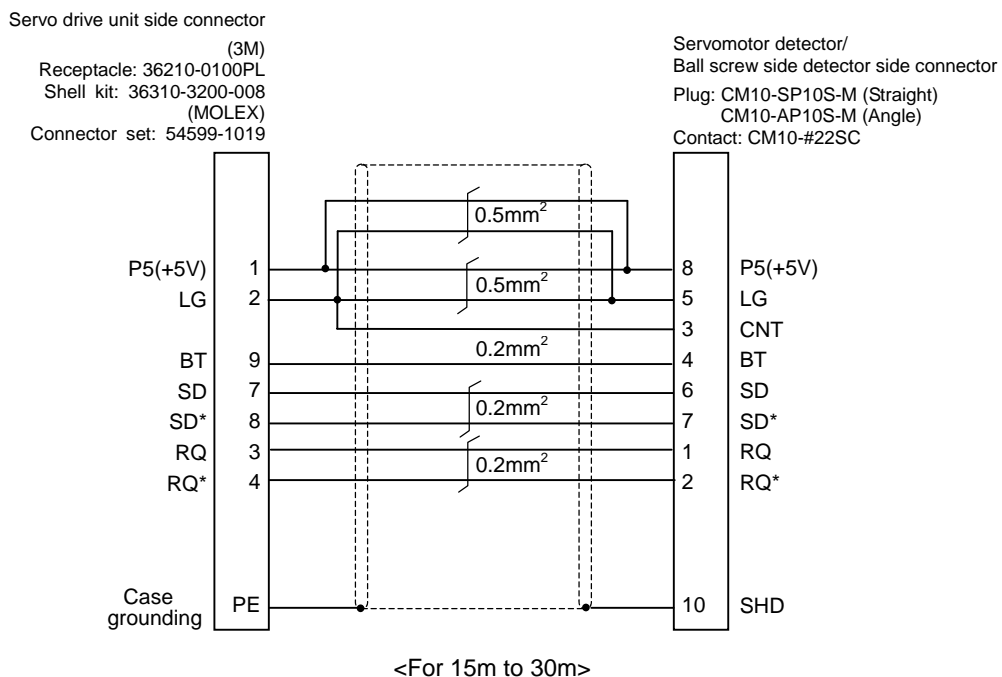
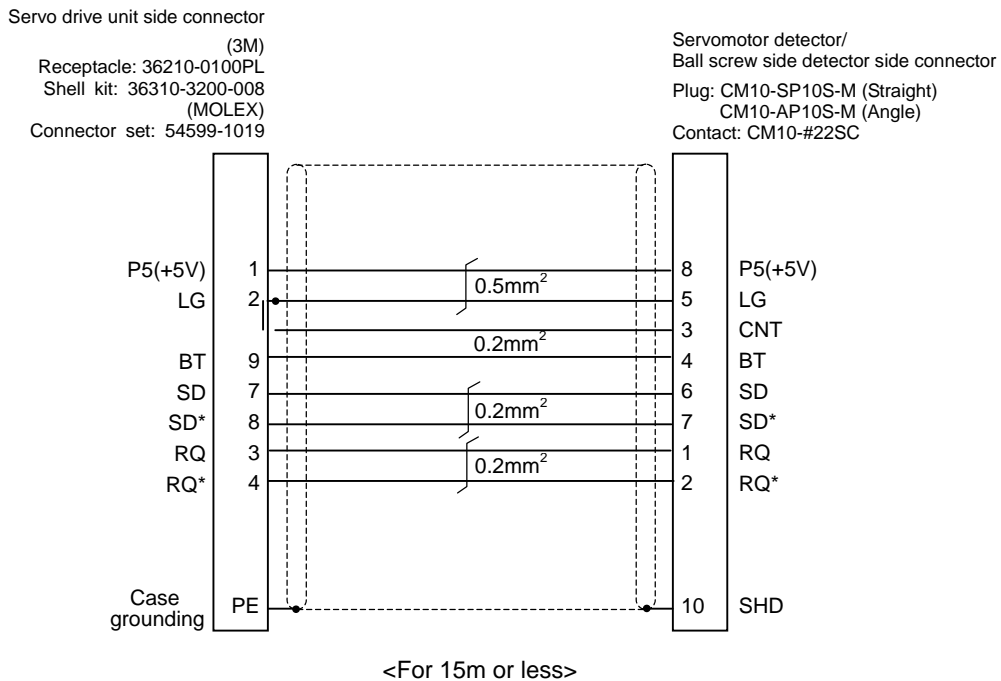

**<CNV2E-HP cable connection diagram>**

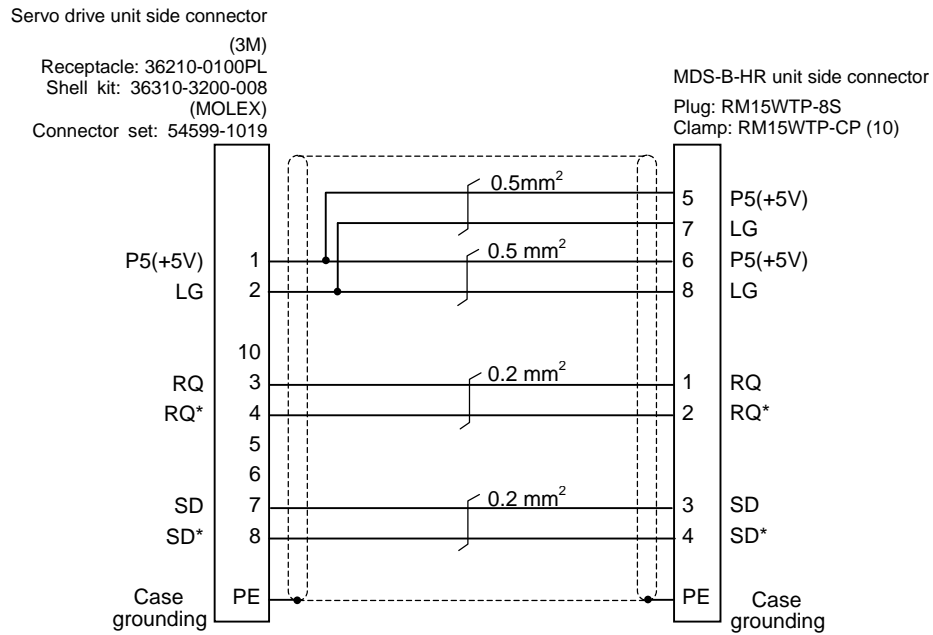

**<Cable connection diagram between scale I/F unit and scale (CNLH3 cable, etc.)>**

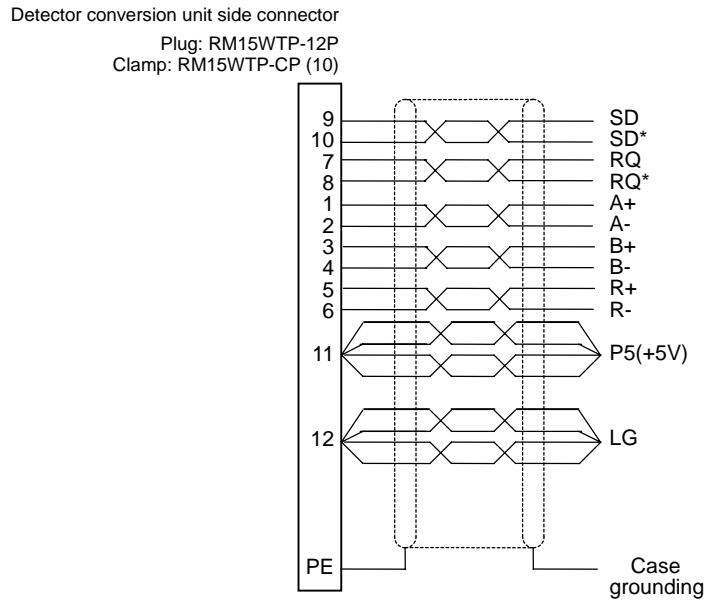

(Note) This cable must be prepared by the user.

<Oblong wave communication detector (linear scale, etc.) cable connection diagram>

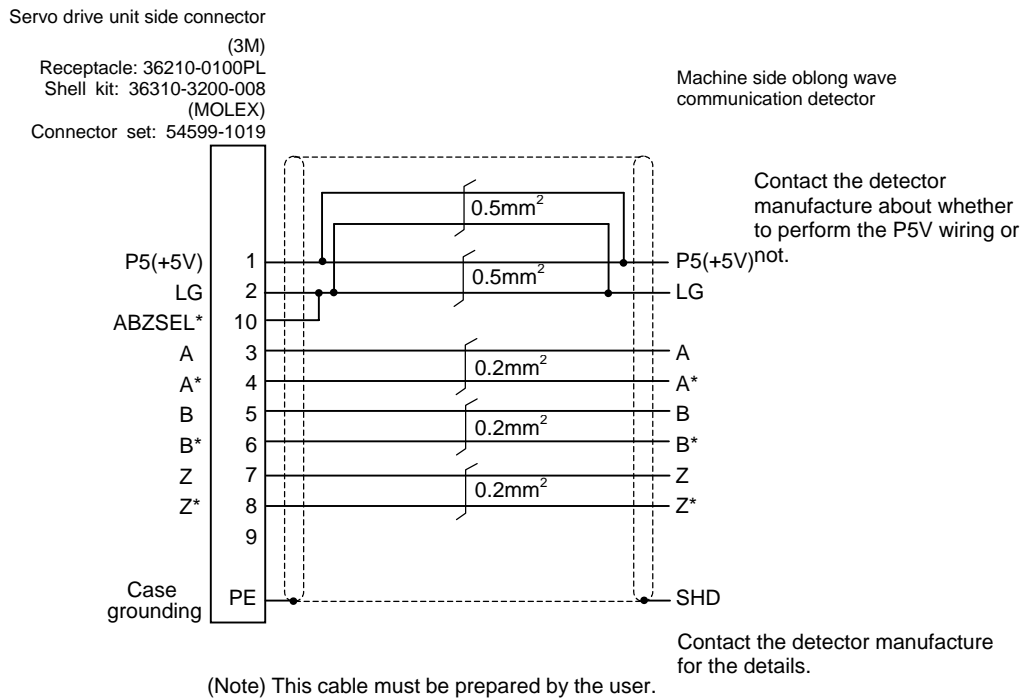

<Serial communication detector (linear scale, etc.) cable connection diagram>

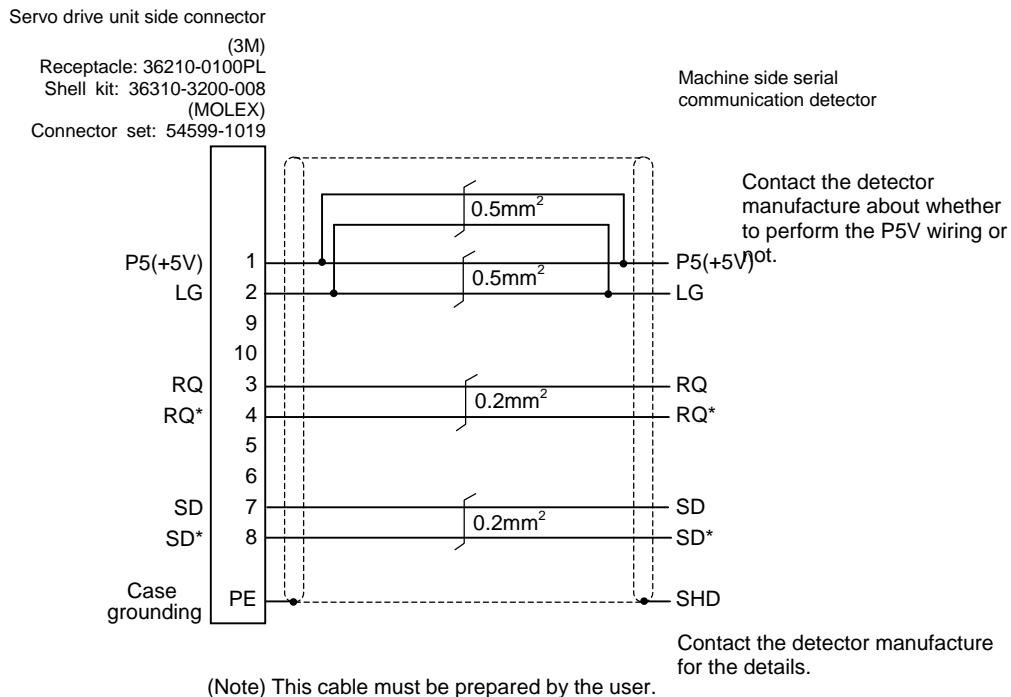

**POINT**

For compatible detector, refer to the section “4-1 Servo option” in MDS-D-SVJ3/SPJ3 series Specifications Manual.

**5.2.2 Spindle Detector Cable**

**<CNP2E-1 cable connection diagram>**

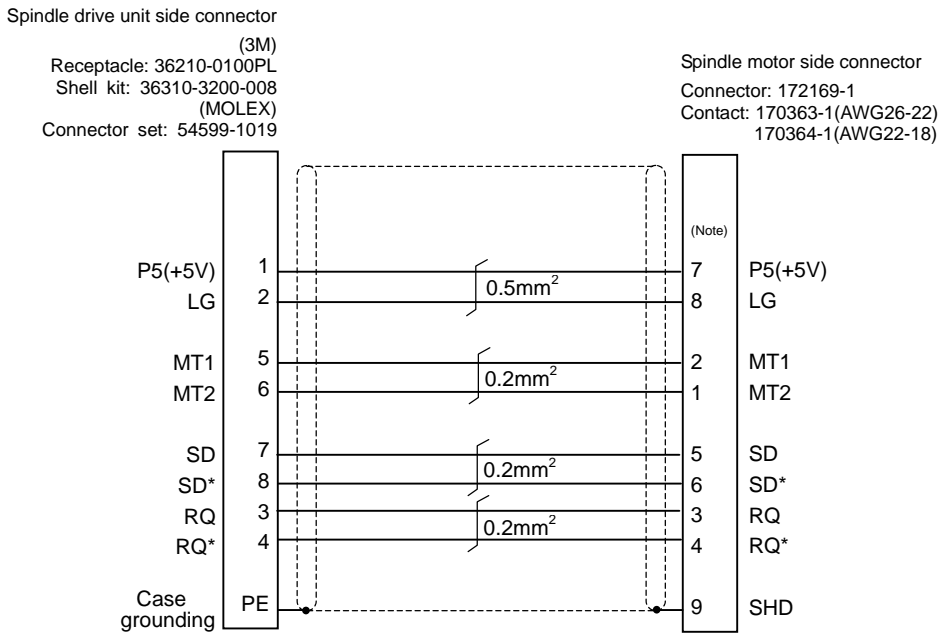

<For 15m or less>

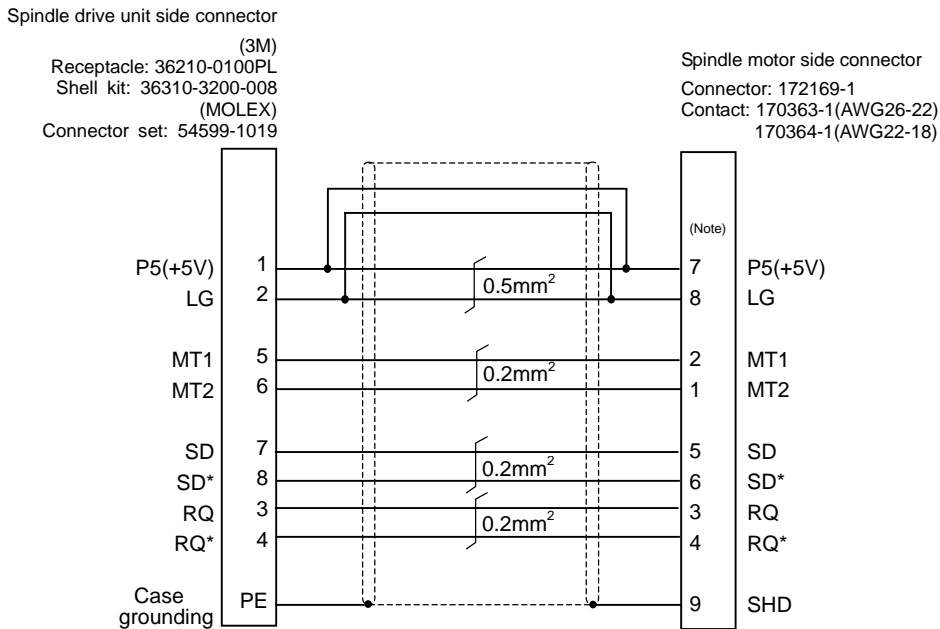

<For 15m to 30m>

**Appendix 5. Servo/Spindle Cable and Connector Specifications (MDS-D-SVJ3/SPJ3)**  
**5.2 Cable Connection Diagram**

**<CNP3EZ-2P, CNP3EZ-3P cable connection diagram>**

Spindle drive unit side connector  
 (3M)  
 Receptacle: 36210-0100PL  
 Shell kit: 36310-3200-008  
 (MOLEX)  
 Connector set: 54599-1019

Spindle motor side connector  
 Connector: MS3106A20-29S(D190)  
 Back shell: CE02-20BS-S (straight)  
 CE-20BA-S (angle)  
 Clamp: CE3057-12A-3

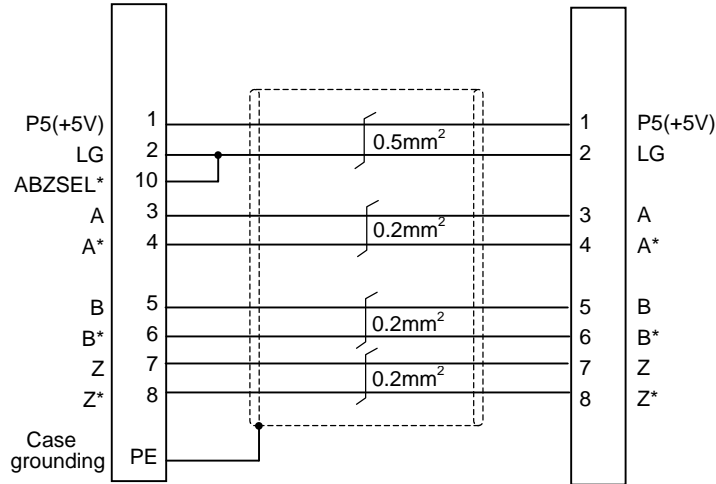

<For 15m or less>

Spindle drive unit side connector  
 (3M)  
 Receptacle: 36210-0100PL  
 Shell kit: 36310-3200-008  
 (MOLEX)  
 Connector set: 54599-1019

Spindle motor side connector  
 Connector: MS3106A20-29S(D190)  
 Back shell: CE02-20BS-S (straight)  
 CE-20BA-S (angle)  
 Clamp: CE3057-12A-3

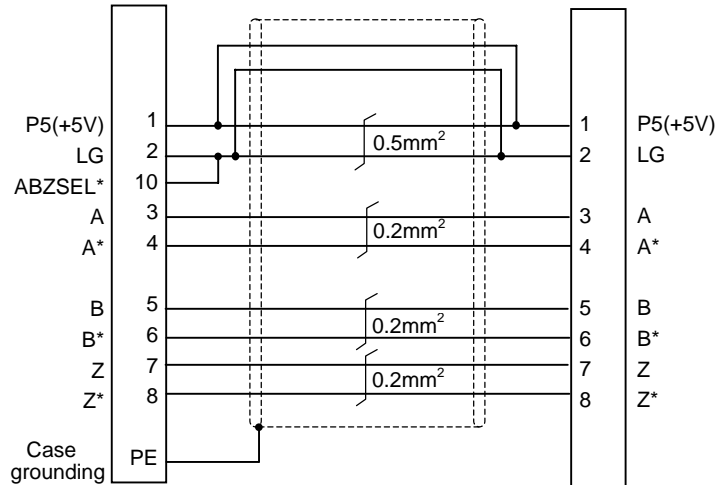

<For 15m to 30m>

5.2.3 C Axis Detector Cable (For Serial Interface Conversion Unit APE391M Connection)

<Serial communication detector cable connection diagram>

Spindle drive unit side connector  
 (3M)  
 Receptacle: 36210-0100PL  
 Shell kit: 36310-3200-008  
 (MOLEX)  
 Connector set: 54599-1019

APE391M side connector

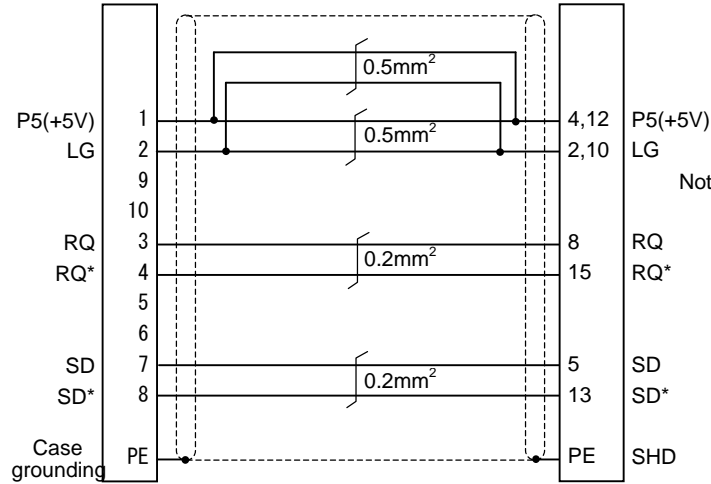

Note: Check with the manufacturer of the detector to be connected whether to do P5V wiring.

Contact the detector manufacturer.

(Note) The cable must be prepared by the user.

### 5.3 Connector Outline Dimension Drawings

#### 5.3.1 Optical Communication Cable

##### (1) For wiring between drive units (inside panel)

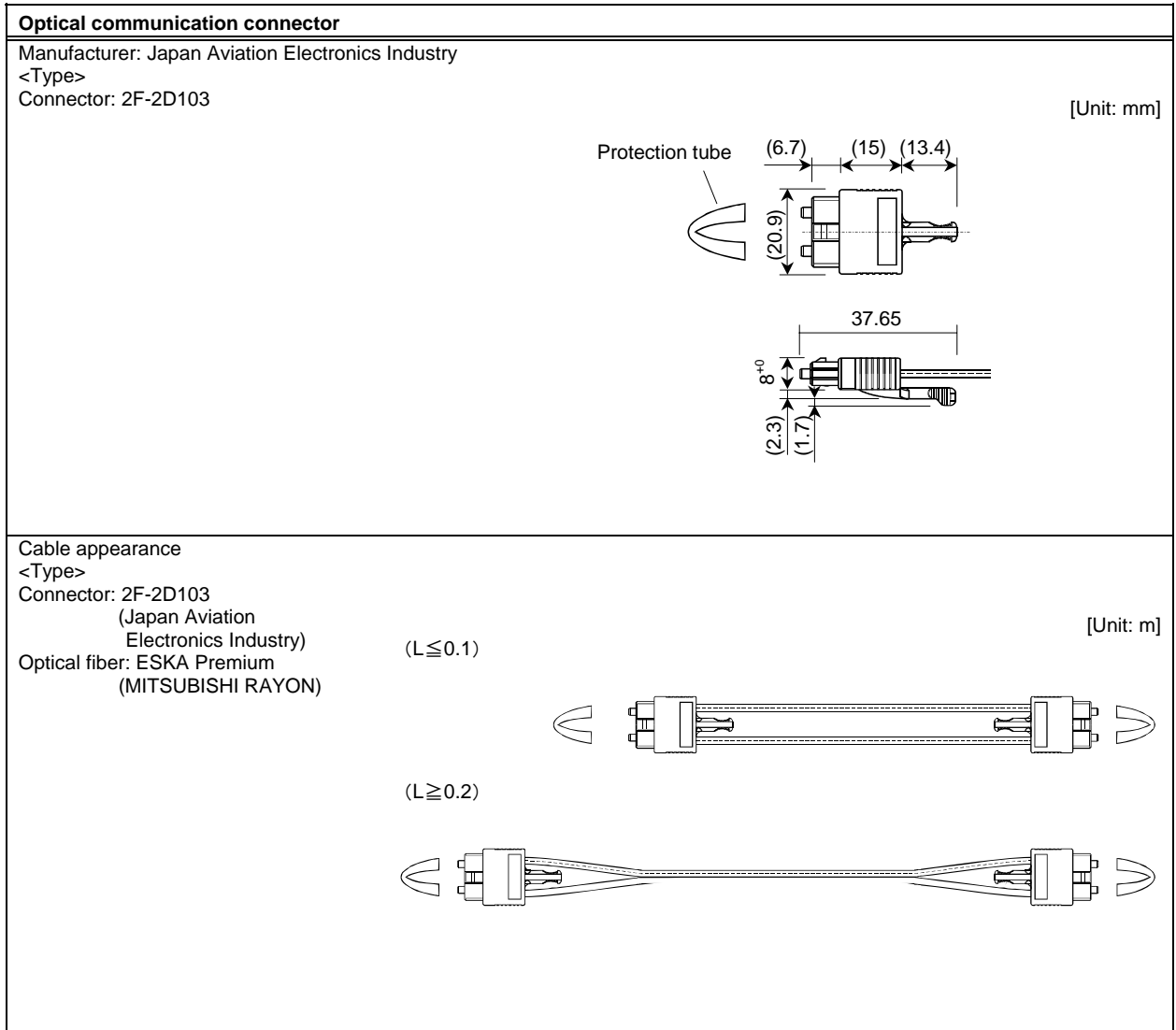

- (Note 1)** The POF fiber's light amount will drop depending on how the fibers are wound. So, try to avoid wiring the fibers.  
**(Note 2)** Do not wire the optical fiber cable to moving sections.



(2) For wiring between drive units (outside panel)

Optical communication connector	
Manufacturer: Tyco Electronics AMP <Type> Connector: 1123445-1	[Unit: mm]
Cable appearance <Type> Connector: 1123445-1 (Tyco Electronics AMP) Optical fiber: ESKA Premium (MITSUBISHI RAYON)	

- (Note 1) The PCF fiber's light amount will drop depending on how the fibers are wound. So, try to avoid wiring the fibers.  
 (Note 2) Do not wire the optical fiber cable to moving sections.

5.3.2 Servo Detector Connector

<p><b>Motor side detector connector / Ball screw side detector for connector</b></p>	
<p>Manufacturer: DDK                  &lt;Type&gt;                  Plug: CM10-SP10S-M</p>	<p>[Unit: mm]</p>
<p>Manufacturer: DDK                  &lt;Type&gt;                  Plug: CM10-AP10S-M</p>	<p>[Unit: mm]</p>

**(Note)** For the manufacturing method of CM10 series connector, refer to the section "Cable and connector assembly" in MDS-D-SVJ3/SPJ3 Instruction Manual.

**Appendix 5. Servo/Spindle Cable and Connector Specifications (MDS-D-SVJ3/SPJ3)**  
**5.3 Connector Outline Dimension Drawings**

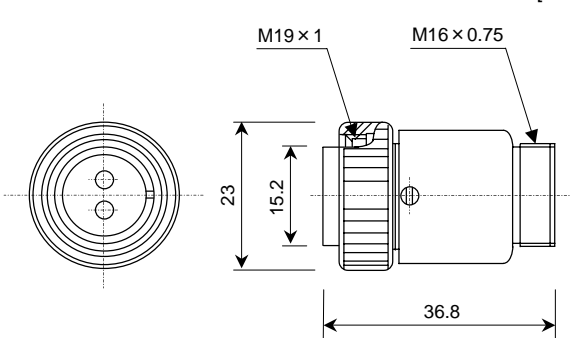
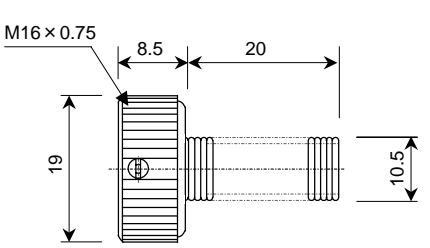
<p><b>MDS-B-HR connector</b>          Manufacturer: Hirose Electric          &lt;Type&gt;          Plug: RM15WTP-8S</p> <p style="text-align: right;">[Unit: mm]</p> 
<p>Manufacturer: Hirose Electric          &lt;Type&gt;          Clamp: RM15WTP-CP (10)</p> <p style="text-align: right;">[Unit: mm]</p> 

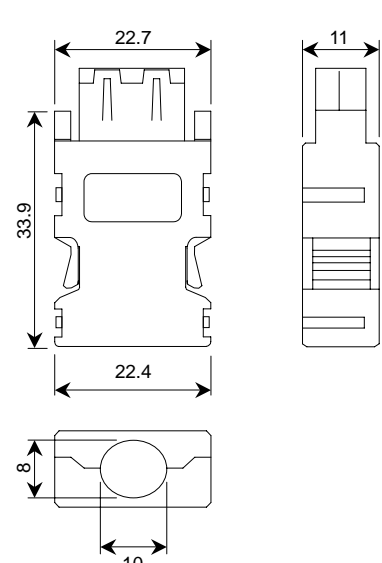
<p><b>Servo drive unit connector for CN2/3</b>          Manufacturer: 3M          &lt;Type&gt;          Receptacle: 36210-0100PL          Shell kit: 36310-3200-008</p> <p>Manufacturer: MOLEX          &lt;Type&gt;          Connector set: 54599-1019</p> <p style="text-align: right;">[Unit: mm]</p> 
---

5.3.3 Brake Connector

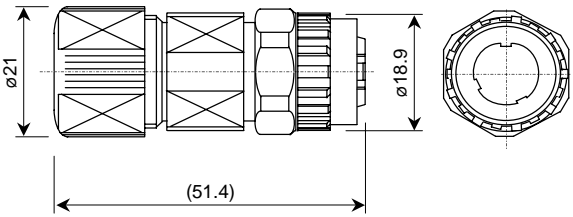
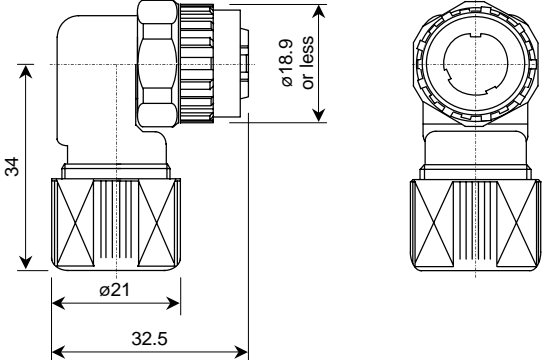
<p><b>Brake connector for HF</b>                  Manufacturer: DDK                  &lt;Type&gt;                  Plug: CM10-SP2S-S</p> <p style="text-align: right;">[Unit: mm]</p> 
<p>Manufacturer: DDK                  &lt;Type&gt;                  Plug: CM10-AP2S-S</p> <p style="text-align: right;">[Unit: mm]</p> 

**(Note)** For the manufacturing method of CM10 series connector, refer to the section "Cable and connector assembly" in MDS-D-SVJ3/SPJ3 Instruction Manual.

**Appendix 5. Servo/Spindle Cable and Connector Specifications (MDS-D-SVJ3/SPJ3)**  
**5.3 Connector Outline Dimension Drawings**

**5.3.4 Power Connector**

**Motor power connector**  
 Manufacturer: DDK

Plug: [Unit: mm]

Type	A	B <sup>+0</sup> / <sub>-0.38</sub>	C±0.8	D or less	W
CE05-6A18-10SD-C-BSS	1 <sup>1</sup> / <sub>8</sub> -18UNEF-2B	34.13	32.1	57	1-20UNEF-2A
CE05-6A22-22SD-C-BSS	1 <sup>3</sup> / <sub>8</sub> -18UNEF-2B	40.48	38.3	61	1 <sup>3</sup> / <sub>16</sub> -18UNEF-2A

---

Manufacturer: DDK

Plug: [Unit: mm]

Type	A	B <sup>+0</sup> / <sub>-0.38</sub>	D or less	W	R±0.7	U±0.7	(S) ±1	Y or more
CE05-8A18-10SD-C-BAS	1 <sup>1</sup> / <sub>8</sub> -18UNEF-2B	34.13	69.5	1-20UNEF-2A	13.2	30.2	43.4	7.5
CE05-8A22-22SD-C-BAS	1 <sup>3</sup> / <sub>8</sub> -18UNEF-2B	40.48	75.5	1 <sup>3</sup> / <sub>16</sub> -18UNEF-2A	16.3	33.3	49.6	7.5

---

Manufacturer: DDK

Clamp: [Unit: mm]

Type	Shell size	Total length	Outer dia.	Avail. screw length	D	E	F	G	H	Fitting screw	Bushing	Applicable cable
CE3057-10A-1(D240)	18	23.8	30.1	10.3	41.3	15.9	14.1	31.7	3.2	1-20UNEF-2B	CE3420-10-1	φ10.5~φ14.1
CE3057-12A-1(D240)	20	23.8	35	10.3	41.3	19	16.0	37.3	4	1 <sup>3</sup> / <sub>16</sub> -18UNEF-2B	CE3420-12-1	φ12.5~φ16.0

**Appendix 5. Servo/Spindle Cable and Connector Specifications (MDS-D-SVJ3/SPJ3)**  
**5.3 Connector Outline Dimension Drawings**

**5.3.5 Drive Unit Side Main Circuit Connector**

**Drive unit CNP1 connector (for power supply), CNP3 connector (for motor power)**

Manufacturer: Molex

[Unit: mm]

Type	A	B	No. of poles
54928-0670	44	37.5	6 (for CNP1)
54928-0370	21.5	15	3 (for CNP3)

---

Manufacturer: Phoenix contact

[Unit: mm]

Type	A	No. of poles
PC4/6-STF-7.62-CRWH	38.10	6 (for CNP1)
PC4/3-STF-7.62-CRWH	15.24	3 (for CNP3)

**Drive unit CNP2 connector (for control power)**

Manufacturer: Molex  
 Connector: 54927-0520

[Unit: mm]

**Appendix 5. Servo/Spindle Cable and Connector Specifications (MDS-D-SVJ3/SPJ3)**  
**5.3 Connector Outline Dimension Drawings**

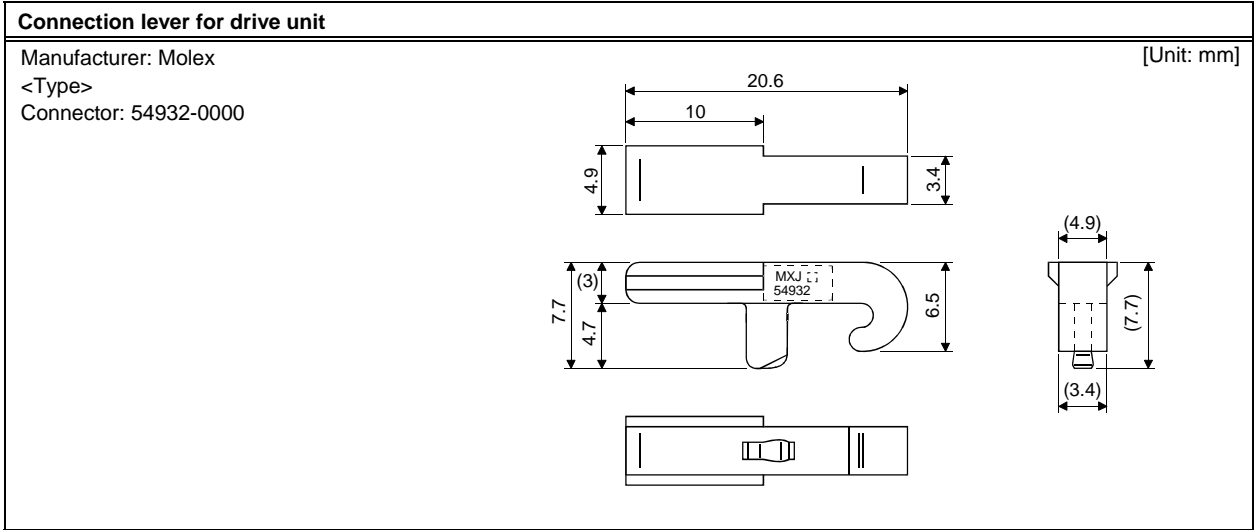

**5.3.6 Spindle Detector Connector**

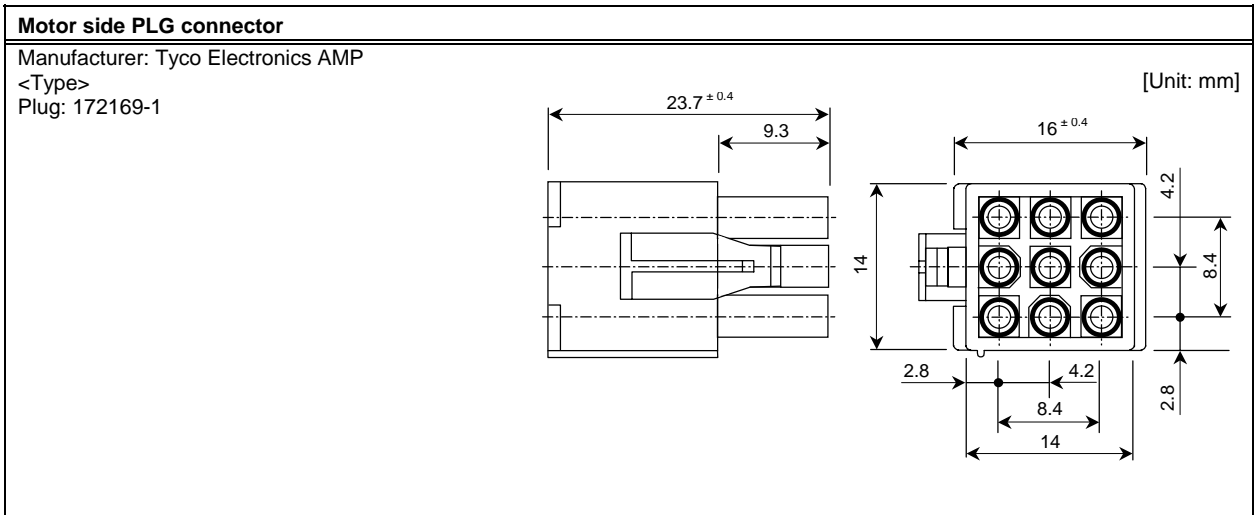
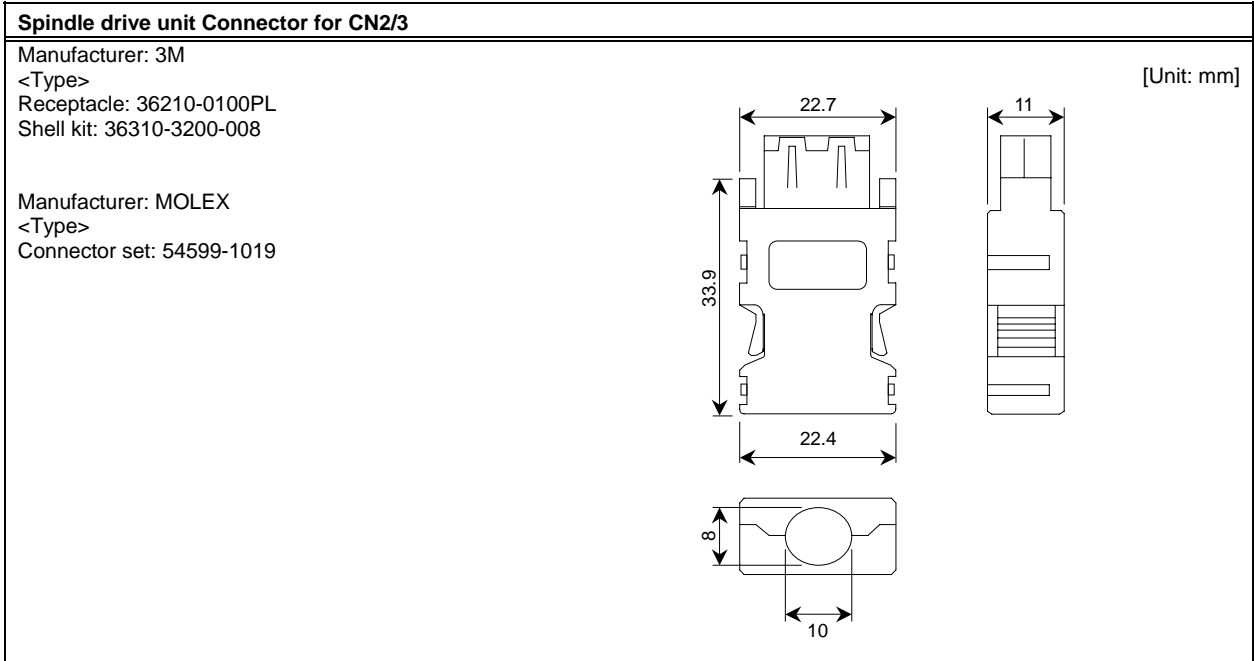



**Appendix 5. Servo/Spindle Cable and Connector Specifications (MDS-D-SVJ3/SPJ3)**  
**5.3 Connector Outline Dimension Drawings**

<p><b>Spindle side detector connector (for OSA1024)</b></p> <p>Manufacturer: DDK          &lt;Type&gt;          Connector: MS3106A20-29S (D190)</p> <p style="text-align: right;">[Unit: mm]</p>
<p>Manufacturer: DDK          &lt;Type&gt;          Straight back shell: CE02-20BS-S</p> <p style="text-align: right;">[Unit: mm]</p>
<p>Manufacturer: DDK          &lt;Type&gt;          Angle back shell: CE-20BA-S</p> <p style="text-align: right;">[Unit: mm]</p>
<p>Manufacturer: DDK          &lt;Type&gt;          Cable clamp: CE3057-12A-3</p> <p style="text-align: right;">[Unit: mm]</p>

## Appendix 6. Precautions for Wiring M700 Series

### 6.1 Connecting the Optical Fiber Cable

An optical fiber cable is used for communication between the control unit and MDS-D/DH Series drive unit. Special precautions, differing from the conventional cable, are required when laying and handling the optical fiber cable.

#### 6.1.1 Outline of Optical Fiber Cable and Names of Each Part

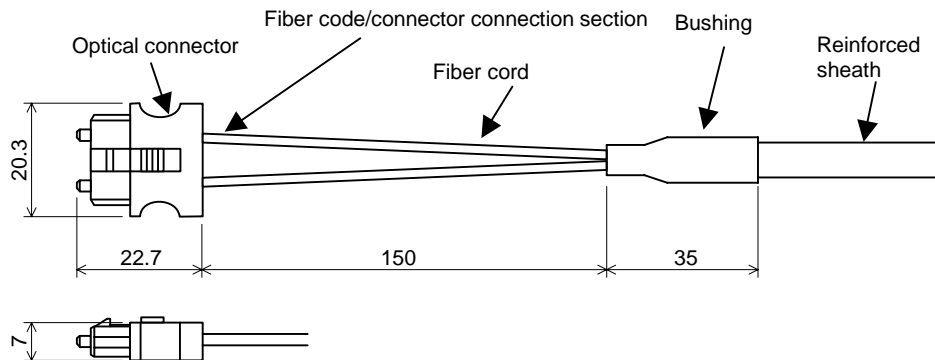

To ensure the system performance and reliability, purchase the optical fiber cable from Mitsubishi. A machining drawing is given in "Appendix 2." as reference, but the purchased optical fiber cable cannot be cut or connected by the machine tool builder.

#### 6.1.2 Precautions for Handling Optical Fiber Cable

- (1) A protective cap is attached to the optical module and optical fiber cable mounted on the PCB when the system is delivered. Leaving this protective cap unattached could result in connection faults from the adherence of dirt and dust. Do not remove the protective cap when not connecting the cable. If dirty, wipe off lightly with a piece of dry gauze, etc. (Do not use solvents such as alcohol as the optical fiber material could melt.)
- (2) Hold the connector section when connecting or disconnecting the optical connector. Holding the fiber cord will result in force exceeding the tolerable tension on the fiber cord and connector connection section, and could cause the fiber cord to dislocate from the optical connector thereby inhibiting use.
- (3) The optical connector cannot be connected in reversed. Check the connector orientation when connecting the optical fiber cable to the optical module. Align the connector lock lever with the lock holes on the PCB's optical module, and press the connector straight in. Confirm that the lock lever connects with the optical module and that a "click" is heard.
- (4) When disconnecting the optical fiber cable from the PCB, press the lock release buttons on the lock lever, and pull out the cable while holding the connector section. The connector could be damaged if the cable is pulled without pressing down on the lock release buttons.
- (5) Do not apply excessive force onto the optical fiber cable by stepping on it or dropping tools, etc., on it.

#### 6.1.3 Precautions for Laying Optical Fiber Cable

- (1) Do not apply a force exceeding the cable's tolerable tension. Binding the cables too tight with tie-wraps could result in an increased loss or a disconnection. Use a cushioning material such as a sponge or rubber when bundling the cables and fix so that the cables do not move.
- (2) Do not connect the cables with a radius less than the tolerable bending radius. Excessive stress could be applied near the connector connection section and cause the optical characteristics to drop. The cable bending radius should be 10 times or more than the outer diameter at the reinforced sheath, and 20 times or more than the outer diameter at the fiber cord section.
- (3) Do not apply torsion to the optical fiber cable. Laying a twisted cable could cause the optical characteristics to drop.
- (4) When laying the cables in a conduit, avoid applying stress on the fiber cord and connector connection section. Use the tensile end such as a pulling eye or cable grip, etc.
- (5) Fix the reinforced sheath with a cable clamp so that the mass of the optical fiber cable is not directly applied on the fiber cord and connector connection section.
- (6) Never bundle the cables with vinyl tape. The plasticizing material in the vinyl tape could cause the POF cable to break.
- (7) Loop the excessive cable with twice or more than the minimum bending radius R.

Recommended clamp material: CKN-13SP KITAGAWA INDUSTRIES.

#### 6.2 Precautions for Connecting Peripheral Devices

- (1) There is compatibility between the devices connected to the commercially available compact flash memory and USB interface, so not all operations can be guaranteed. The operation must be confirmed by the machine tool builder.  
The dustproof properties, splashproof properties and noise effect, etc., of the commercially available devices may not be taken into consideration in all cases.

#### 6.3 Precautions for Connecting 24V Power Supply

- (1) When 24V power is supplied to the unit (control unit, display unit) under the following conditions, welding may occur on the contacts due to rush current; so be careful.

When 24VDC's ON/OFF are directly controlled by a magnetic switch such as relay AND  
When heat capacity of the contacts for relay, etc. used to control 24VDC's ON/OFF is small.

#### 6.4 Connection Example When Not Using Operation Panel I/O Unit

Connection examples when not using operation panel I/O unit are introduced in this section.

(Note) Operation panel I/O unit is effective to simplify the wiring, etc.

Whether or not to adopt the operation panel I/O unit should be carefully considered at the machine tool builder side.

##### [Examples when not using operation panel I/O unit]

**(Example 1)** When operation area is made by using card-sized I/O card or scan I/O card, etc.

**(Example 2)** When electric cabinet (control unit section) and operation panel (display unit section) are placed within the same control panel.

(When the space between control unit and display unit is small, and simplification of wiring between those units is not as significant.)

**(Example 3)** When machine operation panel and keyboard unit are not necessary to be installed by using a display unit with touch panel.

The following is a general connection diagram when not using operation I/O unit.

(Examples when using display unit with touch panel)

# Appendix 6. Precautions for Wiring M700 Series

## 6.4 Connection Example When Not Using Operation Panel I/O Unit

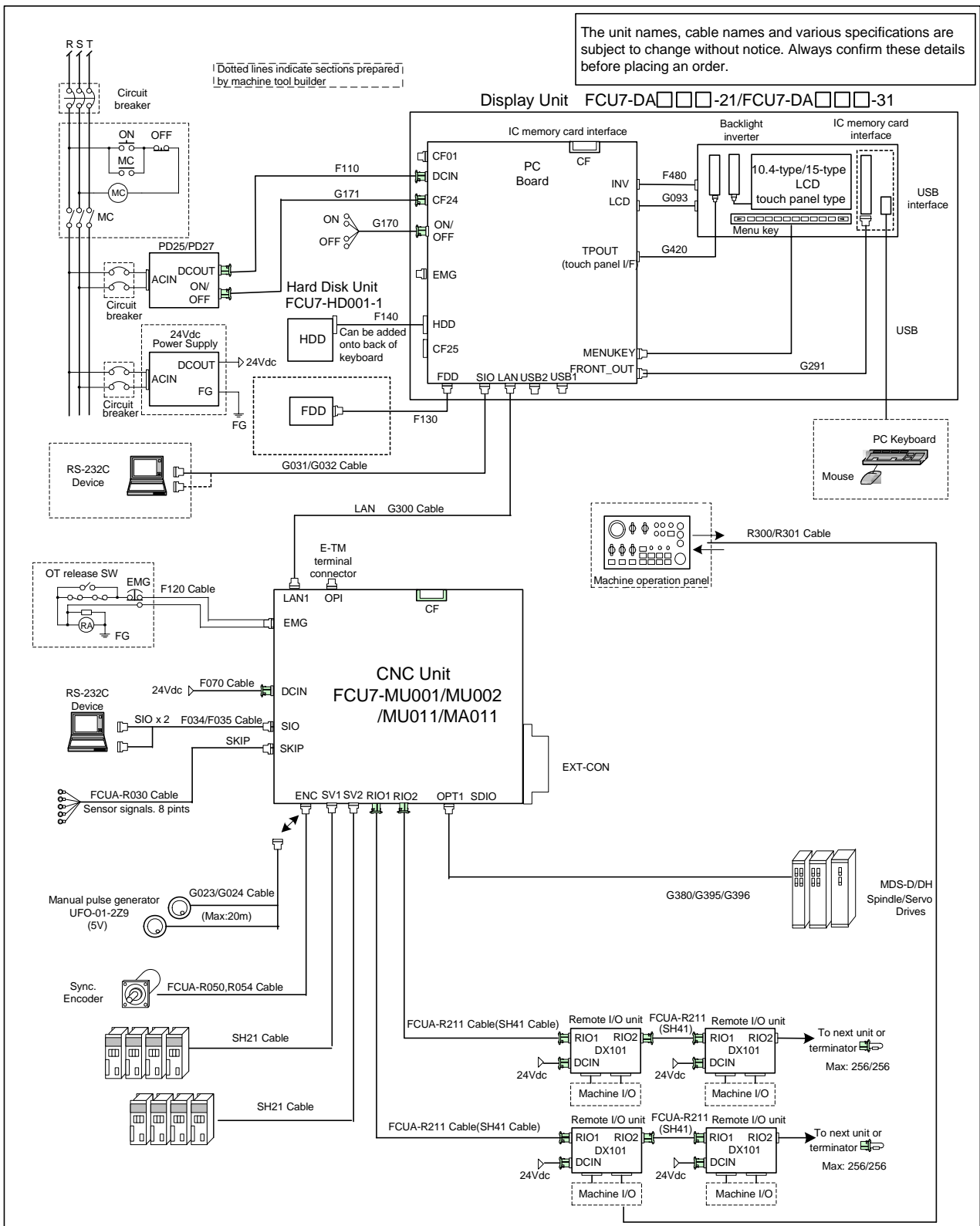

(Note 1) In this connection example, control unit's LAN connector is occupied for communication with display unit. So, external LAN communication directly from control unit is not possible.

(Note 2) Always connect terminal connector E-TM (separately sold) to control unit's OPI connector. If not connected, no operation occurs due to emergency stop state.

## 6.5 Ferrite Core Installation Method

Ferrite cores come with each unit. Connect them in the following manner.

- (1) Wind a cable once around the ferrite core.
- (2) Attach the case by pressing until a click sound is heard.
- (3) Fix with a binding band so that the ferrite core position does not shift.

[24VDC input cable]

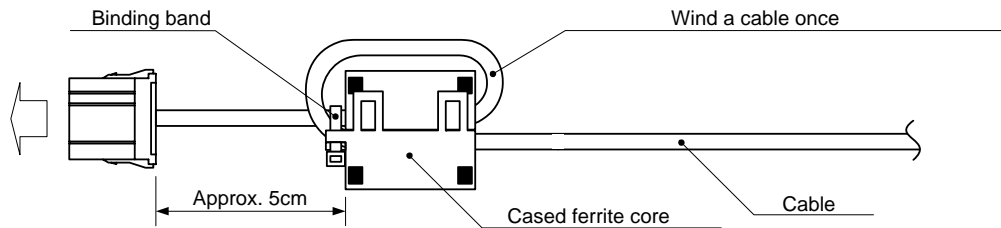

Connect the cable to MITSUBISHI operation panel I/O unit 24VDC input connector.

[RS-232C cable]

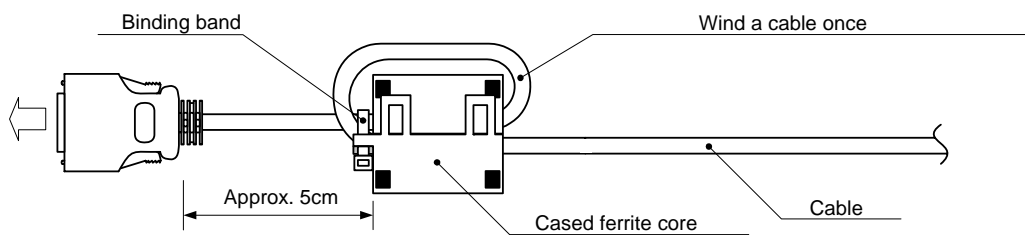

Connect the cable to MITSUBISHI display unit RS-232C connector.

## 6.6 Example of Handy Terminal Connections

The items related to handy terminal connections are explained in this section.

### 6.6.1 Environment Specifications for Handy Terminal

Item	Unit name		Handy terminal
	Type		HG1T-SB12UH-MK1346-L5
General specifications	Ambient temperature	During operation	0 to 40°C
		During storage	-20 to 60°C
	Ambient humidity		Long term: 10 to 75%RH (with no dew condensation)
			Short term: 10 to 95%RH (with no dew condensation) (Note 1)
	Vibration resistance	During operation	9.8m/s <sup>2</sup> [1.0G] or less 10 to 55Hz
	Shock resistance	During storage	98m/s <sup>2</sup> [10.0G] or less
	Working atmosphere		No corrosive gases, dust or oil mist
Power specifications	Power voltage		24VDC±5%, ripple noise 240mV (P-P)
	Current consumption	(max)	0.2A
	Instantaneous stop tolerance time		24VDC: 4ms or less
Others	Heating value		4W (max)
	Mass		600g

(Note 1) The period defined as "short term" is within one month.

(Note 2) The unit is an IP65F equivalent.

6.6.2 Outline Drawing of Handy Terminal

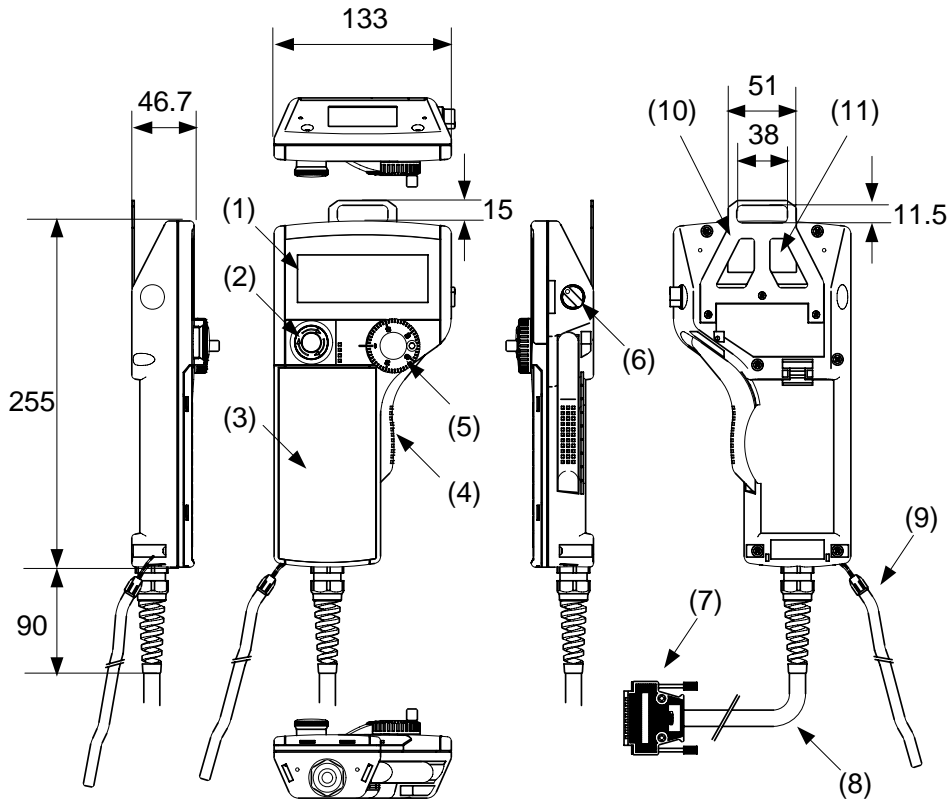



Explanation of handy terminal functions

No.	Name	Function/Specification	No.	Name	Function/Specification
(1)	LCD	Monochrome display with backlight 192(W) x 64(H) dots	(7)	HOST	Host interface connector (DDK:17JE-23250-02(D8A6))
(2)	SW1	Emergency stop switch Contact rating/Contact: 24VDC, 1A Contact configuration: 2b contacts (IDEC Corporation: HA1E-V2S2VR)	(8)	-	Host interface cable (5m)
(3)	-	Membrane switch (Note)	(9)	-	Simplified hand strap (IDEC Corporation: HG9Z-PS1)
(4)	SW2	Enable switch Contact rating/Contact: 24VDC, 50mA Contact configuration: 3 position contact x 2 (OFF-ON-OFF) (IDEC Corporation: HE3B-M2)	(10)	-	Panel hanging fitting (IDEC Corporation: HG9Z-TK1)
(5)	SW4	Manual pulse generator Output: Open collector 4.7kΩ pull-up resistor is connected. (TOKYO SOKUTEIKIZAI CO., LTD: RE19PH50C16RR)	(11)	-	Serial number plate
(6)	SW6	Selector switch			

(Note) Cautions about simultaneous pressing of multiple switches (impossible): When 3 or more switches are pressed simultaneously, unpressed switches are also detected as pressed ones.

6.6.3 Connections of Handy Terminal

Connect handy terminal to the control unit connector SIO and ENC.  
 Connect the emergency stop switch (SW1), enable switch (SW2), selector switch (SW) and 24VDC input to the control panel terminal block.

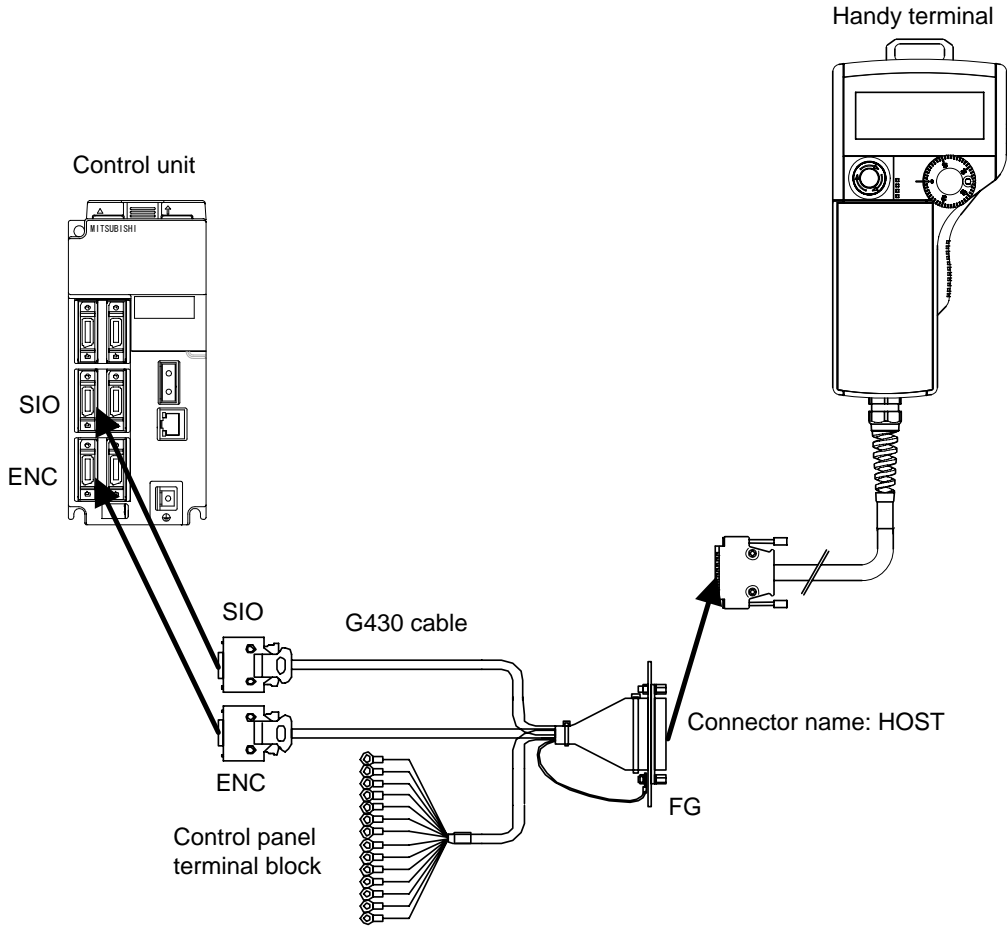

### 6.6.4 Explanation of Handy Terminal Signals and Connection Cables

#### (1) G430 cable

Plug: 10120-3000VL

Shell: 10320-52F0-008

Recommended manufacturer: 3M

Wire material:

UL1061-2464 AWG28 x 3P

Recommended manufacturer:

Oki Electric Cable

Crimp terminal: R1.25-3.5

Recommended manufacturer: JST

Wire material:

UL1061-2464 AWG24 x 8P

Recommended manufacturer:

Oki Electric Cable

**(Note)**

Fold the cable shield over the sheath, and wrap copper foil tape over it. Connect the wound copper foil tape to the connector's GND plate.

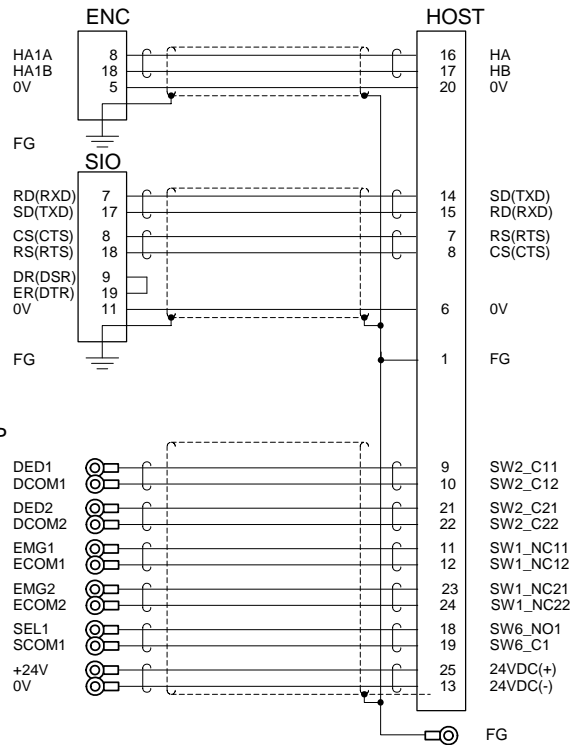

Plug: CDB-25S

Contact: CD-SC-221 x 21

Recommended manufacturer:

Hirose Electric

FG terminal

Crimp terminal: V1.25-4

Recommended manufacturer: JST

Wire material:

UL1061-2464 AWG18 (Green)

Recommended manufacturer:

Oki Electric Cable

## (2) Signal explanation

HOST terminal No.	HOST connector signal name	Input Output	Function/Name
1	FG	-	Frame ground
2	Reserved	-	Reserved
3	Reserved	-	Reserved
4	Reserved	-	Reserved
5	Reserved	-	Reserved
6	0V	-	Communication signal ground
7	RS(RTS)	O	RS-232C communication signal (Request To Send)
8	CS(CTS)	I	RS-232C communication signal (Clear To Send)
9	SW2_C11	-	Enable switch contact 1 terminal 1
10	SW2_C12	-	Enable switch contact 1 terminal 2
11	SW1_NC11	-	Emergency stop switch contact 1 terminal 1
12	SW1_NC12	-	Emergency stop switch contact 1 terminal 2
13	24VDC(-)	I	24VDC ground
14	SD(TXD)	O	RS-232C communication signal (Send Data)
15	RD(RXD)	I	RS-232C communication signal (Receive Data)
16	HA	O	Manual pulse generator A phase signal
17	HB	O	Manual pulse generator B phase signal
18	SW6_NO1	-	Switchover switch terminal 1
19	SW6_C1	-	Switchover switch terminal 2
20	0V	-	Ground
21	SW2_C21	-	Enable switch contact 2 terminal 1
22	SW2_C22	-	Enable switch contact 2 terminal 2
23	SW1_NC21	-	Emergency stop switch contact 2 terminal 1
24	SW1_NC22	-	Emergency stop switch contact 2 terminal 2
25	24VDC(+)	I	24VDC power supply input

**(Note)** The input/output goes to/from the handy terminal.

(3) Terminal connections

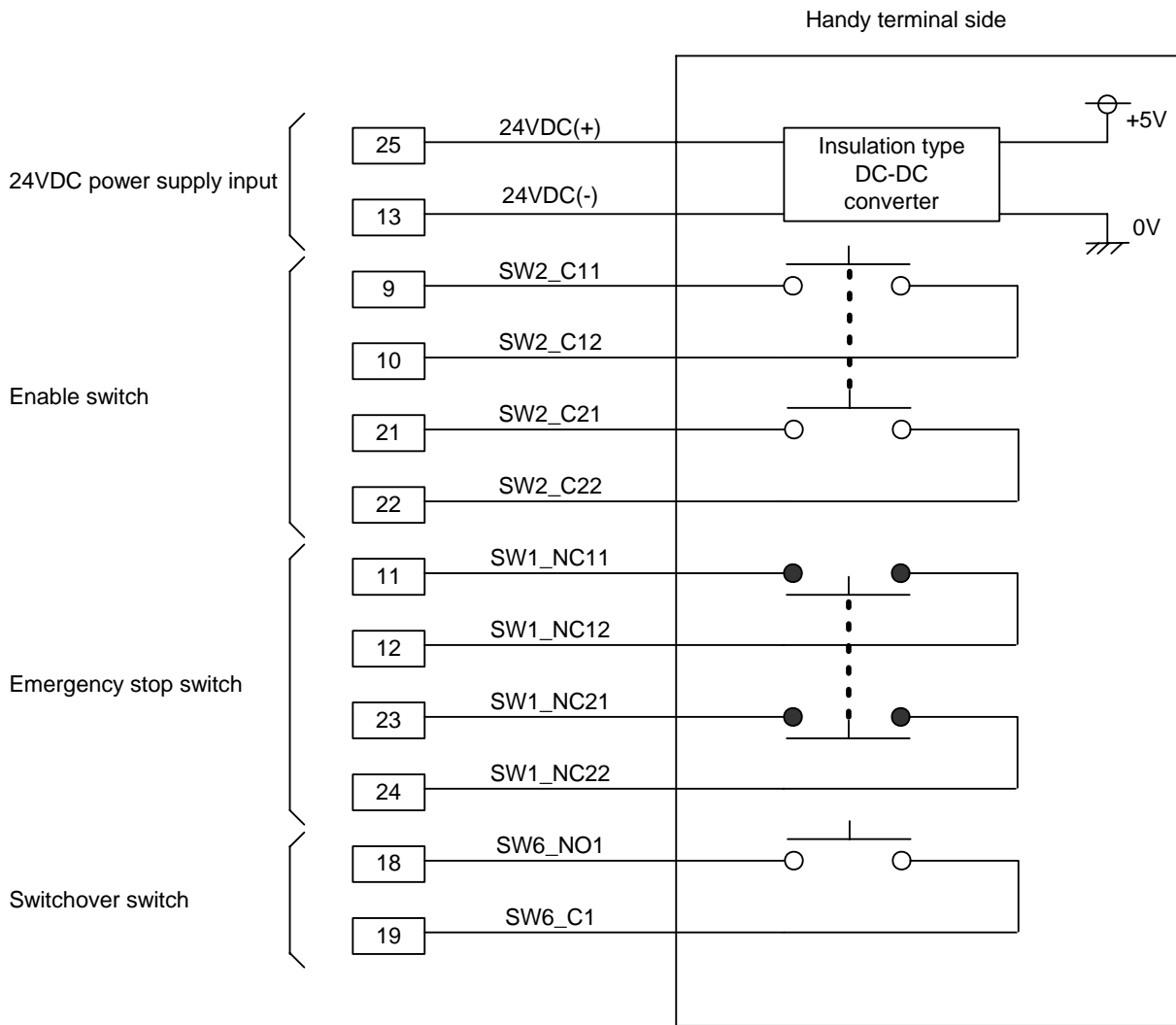

## **Appendix 7. Transportation Restrictions for Lithium Batteries**

### **7.1 Restriction for Packing**

The United Nations Dangerous Goods Regulations "Article 12" became effective from 2003. When transporting lithium batteries with means subject to the UN Regulations, such as by air transport, measures corresponding to the Regulations must be taken. The UN Regulations classify the batteries as dangerous goods (Class 9) or not dangerous goods according to the lithium content.

To ensure safety during transportation, lithium batteries (battery unit) directly exported from Mitsubishi are packaged in a dedicated container (UN package) for which safety has been confirmed. When the customer is transporting these products with means subject to the UN Regulations, such as air transport, the shipper must follow the details explained in the section "Appendix 7.1.2 Handling by User".

#### 7.1.1 Target Products

The following Mitsubishi NC products use lithium batteries. The UN Regulations classify the batteries as dangerous goods (Class 9) or not dangerous goods according to the lithium content. If the batteries subjected to hazardous materials are incorporated in a device and shipped, a dedicated packaging (UN packaging) is not required. However, the item must be packed and shipped following the Packing Instruction 912 specified in the IATA DGR (Dangerous Goods Regulation) book.

Also, all lithium battery products incorporated in a machinery or device must be fixed securely in accordance with the Packing Instruction 900 and shipped with protection in a way as to prevent damage or short-circuits.

#### (1) Products requiring dedicated packaging (Materials falling under Class 9)

Mitsubishi type (Type for arrangement)	Battery type	Lithium metal content	Application	Battery class
MDS-A-BT-4	ER6-B4-11	2.6g	For servo	Battery
MDS-A-BT-6	ER6-B6-11	3.9g	For servo	
MDS-A-BT-8	ER6-B8-11	5.2g	For servo	
FCU6-BT4-D1	Combination of ER6-B4D-11 and ER6	2.6g+0.65g	For NC/ servo	
CR23500SE-CJ5 (Note1)	CR23500SE-CJ5	1.52g	For NC(M500)	Battery cell

#### (2) Products not requiring dedicated packaging (Materials not falling under Class 9)

Mitsubishi type (Type for arrangement)	Battery type	Lithium metal content	Application	Battery class
MDS-A-BT-2	ER6-B2-12	1.3g	For servo	Battery
FCU6-BTBOX series	2CR5	1.96g	For NC/ servo	
CR2032 (for built-in battery)	CR2032	0.067g	For NC	Battery cell
CR2450 (for built-in battery)	CR2450	0.173g	For NC	
ER6, ER6V series (for built-in battery)	ER6, ER6V	0.7g	For NC/servo	
A6BAT(MR-BAT)	ER17330V	0.48g	For servo	
Q6BAT	Q6BAT	0.49g	For NC	
MR-J3BAT	ER6V	0.65g	For servo	

**(Note 1)** When CR23500SE-CJ5 is incorporated in the unit, this battery is not subject to the regulation.

**(Note 2)** Dedicated packaging is required if the shipment exceeds 12 batteries/24 battery cells. Package the batteries so that this limit is not exceeded.

**(Note 3)** The battery units labelled as "FCUA-" instead of "MDS-A-" also use the same battery.

**(Note 4)** Always use the cell battery (A6BAT) in combination with the dedicated case (MDS-BTCASE). Maximum 8 (either 2, 4, 6 or 8) cell batteries (A6BAT) can be installed to the dedicated case (MDS-BTCASE).

**Example) Rating nameplate for battery units**

<b>MITSUBISHI</b> BATTERY UNIT		
TYPE	MDS-A-BT-6	← Mitsubishi type
OUTPUT DC	3.6 V	
LITHIUM BATTERIES:	ER6 x8 Class 9	← Safety class
	(Battery Type: ER6-B6-11)	← Battery manufacturer type
Mercury Content:	Less than 1 ppm	
Lithium Metal Content:	3.9 g	← Lithium metal content
MITSUBISHI ELECTRIC CORPORATION JAPAN 		

### 7.1.2 Handling by User

The following technical opinion is solely Mitsubishi's opinion. The shipper must confirm the latest IATA Dangerous Goods Regulations, IMDG Codes and laws and orders of the corresponding export country. These should be checked by the company commissioned for the actual transportation.

IATA : International Air Transport Association  
 IMDG Code : A uniform international code for the transport of dangerous goods by seas determined by IMO (International Maritime Organization).

#### ■ When shipping isolated lithium battery products (Packing Instruction 903)

##### (1) Reshipping in Mitsubishi UN packaging

Mitsubishi packing applies the isolated battery's safety test and packaging specifications complying with the UN Regulations (Packing Instruction 903).

The user only needs to add the following details before shipping. (Consult with the shipping company for details.)

##### (a) Indication of container usage mark on exterior box (Label with following details recorded.)

- Proper shipping name (Lithium batteries)
- UN NO. (UN3090 for isolated battery, UN3091 for battery incorporated in a device or included)
- Shipper and consignee's address and name

Example of completing form		
SHIPPER:		CONSIGNEE:
Shipper information		Consignee information
PROPER SHIPPING NAME	LITHIUM BATTERIES	
UN NO. : UN3090	CLASS : 9	SUBSIDIARY RISK
PACKING GROUP : II	PACKING INST. : 903	

##### (b) Preparation of shipping documents (Declaration of dangerous goods)

(Refer to the section "Appendix 7.3 Example of Hazardous Goods Declaration List")

##### (2) When packaged by user

The user must follow UN Regulations when packing, preparing for shipping and preparing the indications, etc.

##### (a) Packing a lithium battery falling under Class 9

- Consult with The Ship Equipment Inspection Society of Japan for details on packaging.
- Prepare for shipping as explained in "(1) Reshipping in Mitsubishi UN packaging".

The Ship Equipment Inspection Society of Japan  
 Headquarters Telephone: 03-3261-6611 Fax: 03-3261-6979

##### (b) Packing a lithium battery not falling under Class 9

- Cells and batteries are separated so as to prevent short circuits and are stored in a strong outer packaging. (12 or less batteries, 24 or less cells.)
- Prepare for the certificates or test results showing compliance to battery safety test. The safety test results have been obtained from the battery manufacturer. (Consult with Mitsubishi when the safety test results are required.)
- Prepare for shipping as explained in "(1) Reshipping in Mitsubishi UN packaging".



#### ■ When shipping lithium batteries upon incorporating in a machinery or device (Packing Instruction 900)

Pack and prepare for shipping the item in accordance with the Packing Instruction 900 specified in the IATA DGR (Dangerous Goods Regulation) book. (Securely fix the batteries that comply with the UN Manual of Tests and Criteria to a machinery or device, and protect in a way as to prevent damage or short-circuit.)

Note that all the lithium batteries provided by Mitsubishi have cleared the UN recommended safety test; fixing the battery units or cable wirings securely to the machinery or device will be the user's responsibility. Check with your shipping company for details on packing and transportation.

#### ■ When shipping a device with lithium batteries incorporated (Packing Instruction 912)

A device incorporating lithium batteries does not require a dedicated packaging (UN packaging). However, the item must be packed, prepared for shipping and labeled following the Packing Instruction 912 specified in the IATA DGR (Dangerous Goods Regulation) book.

Check with your shipping company for details on packing and transportation.

The outline of the Packing Instruction 912 is as follows:

- All the items in the packing instructions for shipping the isolated lithium battery products (Packing Instruction 903) must be satisfied, except for the items related to container, short-circuit, and fixation.
- A device incorporating lithium batteries has to be stored in a strong water-proofed outer packaging.
- To prevent an accidental movement during shipment, securely store the item in an outer packaging.
- Lithium content per device should be not more than 12g for cell and 500g for battery.
- Lithium battery mass per device should be not more than 5kg.

#### 7.1.3 Reference

Refer to the following materials for details on the regulations and responses.

Guidelines regarding transportation of lithium batteries and lithium ion batteries (Edition 2)

..... Battery Association of Japan

## **7.2 Issuing Domestic Law of the United States for Primary Lithium Battery Transportation**

Federal Aviation Administration (FAA) and Research and Special Programs Administration (RSPA) announced an additional regulation (interim final rule) for the primary lithium batteries transportation restrictions item in "Federal Register" on Dec.15 2004. This regulation became effective from Dec.29, 2004. This law is a domestic law of the United States, however it also applies to the domestic flight and international flight departing from or arriving in the United States. Therefore, when transporting lithium batteries to the United State, or within the United State, the shipper must take measures required to transport lithium batteries.

Refer to the Federal Register and the code of Federal Regulation ("Appendix 7.2.4 Reference") for details.

### **7.2.1 Outline of regulation**

- (1) Transporting primary lithium battery by passenger aircraft is forbidden.
  - Excluding primary lithium battery for personal use in a carry-on or checked luggage (Lithium metal content should be not more than 5g for cell and 25g for battery. For details on the lithium metal content, refer to "Appendix 7.1.1 Target Products".)
- (2) When transporting primary lithium battery by cargo aircraft, indicate that transportation by passenger aircraft is forbidden on the exterior box.

### **7.2.2 Target products**

All NC products for which the lithium batteries are used are subject to the regulation. (Refer to the table "Appendix 7.1.1 Target products".)

### **7.2.3 Handling by user**

The "Appendix 7.2.1 Outline of Regulation" described above is solely Mitsubishi's opinion. The shipper must confirm orders of "Appendix 7.2.4 Reference" described below for transportation method corresponding the regulation. Actually, these should be checked by the company commissioned for the actual lithium battery transportation.

#### **(1) Indication of exterior box**

When transporting primary lithium battery by cargo aircraft, indicate that transportation by passenger aircraft is forbidden on the exterior box.

##### **Display example**



- The character color must be displayed with contrast. (black characters against white background, black characters against yellow background, etc.)
- The height (size) of characters to be displayed is prescribed depending on the packaging mass.

When the total mass is over 30kg:	at least 12mm
When the total mass is less than 30kg:	at least 6mm

## Appendix 7. Transportation Restrictions for Lithium Batteries

### 7.2 Issuing Domestic Law of the United States for Primary Lithium Battery Transportation

#### 7.2.4 Reference

- (1) Federal Register (Docket No. RSPA-2004-19884 (HM-224E) ) PDF format  
<http://www.regulations.gov/fredpdfs/05-11765.pdf>
- (2) 49CFR (Code of Federal Regulation, Title49) (173.185 Lithium batteries and cells.)  
[http://www.access.gpo.gov/nara/cfr/waisidx\\_00/49cfr173\\_00.html](http://www.access.gpo.gov/nara/cfr/waisidx_00/49cfr173_00.html)
- (3) DOT regulation body (Department of Transportation)  
<http://hazmat.dot.gov/regs/rules/final/69fr/docs/69fr-75207.pdf>

### 7.3 Example of Hazardous Goods Declaration List

This section describes a general example of the hazardous goods declaration list. For details, please inquire each transportation company.

This will be applied only to the batteries described in "Appendix 7.1 Restriction for Packing".

#### (1) Outline of hazard

<b>Principal hazard and effect</b>	Not found.
<b>Specific hazard</b>	As the chemical substance is stored in a sealed metal container, the battery itself is not hazardous. But when the internal lithium metal attaches to human skin, it causes a chemical skin burn. As a reaction of lithium with water, it may ignite or forms flammable hydrogen gas.
<b>Environmental effect</b>	Not found.
<b>Possible state of emergency</b>	Damages or short-circuits may occur due to external mechanical or electrical pressures.

#### (2) First-aid measure

<b>Inhalation</b>	If a person inhales the vapor of the substance due to the battery damage, move the person immediately to fresh air. If the person feels sick, consult a doctor immediately.
<b>Skin contact</b>	If the content of the battery attaches to human skin, wash off immediately with water and soap. If skin irritation persists, consult a doctor.
<b>Eye contact</b>	In case of contact with eyes due to the battery damage, rinse immediately with a plenty of water for at least 15 minutes and then consult a doctor.
<b>Ingestion</b>	If swallowed, consult a doctor immediately.

#### (3) Fire-fighting measure

<b>Appropriate fire-extinguisher</b>	Dry sand, dry chemical, graphite powder or carbon dioxide gas
<b>Special fire-fighting measure</b>	Keep the battery away from the fireplace to prevent fire spreading.
<b>Protectors against fire</b>	Fire-protection gloves, eye/face protector (face mask), body/skin protective cloth

#### (4) Measure for leakage

<b>Environmental precaution</b>	Dispose of them immediately because strong odors are produced when left for a long time.
<b>How to remove</b>	Get them absorbed into dry sand and then collect the sand in an empty container.

#### (5) Handling and storage

<b>Handling</b>	<b>Cautions for safety handling</b>	Do not peel the external tube or damage it. Do not dispose of the battery in fire or expose it to heat. Do not immerse the battery in water or get it wet. Do not throw the battery. Do not disassemble, modify or transform the battery. Do not short-circuit the battery.
	<b>Appropriate storage condition</b>	Avoid direct sunlight, high temperature and high humidity. (Recommended temp. range: +5 to +35 °C, humidity: 70%RH or less)
<b>Storage</b>	<b>Material to avoid</b>	Flammable or conductive material (Metal: may cause a short-circuit)

## Appendix 7. Transportation Restrictions for Lithium Batteries

### 7.3 Example of Hazardous Goods Declaration List

#### (6) Physical/chemical properties

<b>Appearance</b>	<b>Physical form</b>	Solid
	<b>Shape</b>	Cylinder type
	<b>Smell</b>	Odorless
	<b>pH</b>	Not applicable (insoluble)
	<b>Boiling point/Boiling range, Melting point, Decomposition temperature, Flash point</b>	No information

#### (7) Stability and reactivity

<b>Stability</b>	Stable under normal handling condition.
<b>Condition to avoid</b>	Do not mix multiple batteries with their terminals uninsulated. This may cause a short-circuit, resulting in heating, bursting or ignition.
<b>Hazardous decomposition products</b>	Irritative or toxic gas is emitted in the case of fire.

#### (8) Toxicological information

As the chemical substance is stored in a sealed metal container, the battery has no harmfulness. Just for reference, the table below describes the main substance of the battery.

(Lithium metal)

<b>Acute toxicity</b>	No information
<b>Local effect</b>	Corrosive action in case of skin contact

#### (9) Ecological information

<b>Mobility, Persistence/Decomposability, Bio-accumulation potential, Ecological toxicity</b>	Not found.
---	------------

#### (10) Caution for disposal

Dispose of the battery following local laws or regulations.

Pack the battery properly to prevent a short-circuit and avoid contact with water.

### Appendix 8. Precautions for Compliance to UL/c-UL Standards

Observe the following matters to comply with UL/c-UL Standards.

Refer to "UL/c-UL Standards Compliance Unit Instruction Manual" (BNP-A2993-81) for details.

- (1) Selection of external 24VDC power supply unit (The unit shall be prepared by the machine tool builder.)  
MITSUBISHI CNC700 Series numerical control unit complies with the UL Standards on the condition that the stabilized power supply unit supplying 24VDC to each unit is a UL-approved part.  
Use a UL-approved part for the stabilized power supply unit supplying 24VDC to each unit.
- (2) Unit ambient temperature  
MITSUBISHI CNC700 Series numerical control unit complies with the UL Standards on the condition that the unit is used at a temperature less than the maximum ambient temperature given in chapter 3.  
Make sure that the maximum ambient temperature of each unit does not exceed the temperature given in chapter 3.

## Appendix 9. Precautions for Use of Peripheral Devices and Commercially Available Devices

Peripheral device	Precautions
CF card	<p>Commercially available CF cards may not be compatible with MITSUBISHI units or suitable for FA environment for temperature- or noise-wise. In the case of using it, careful performance check must be required by the machine tool builder.</p> <p>When inserting/removing a commercially available CF card, preferably, turn the MITSUBISHI device's power OFF to avoid any troubles. When inserting/removing a card while the power is ON, make sure to have sufficient time (approx. ten seconds or more) in between.</p> <p>Do not pull out the card or turn OFF the power during access to the CF card. Failure to observe this could cause the memory contents to be erased. In case of emergency, always perform backups by having your important data duplicated, etc. as MITSUBISHI will not guarantee the broken or lost data. Be sure to inform this matter to the end users.</p> <p>Recommended products are the SanDisk products listed below:</p> <p>64MB SDCFB-64-J60 (JAN: 4523052000294)  128MB SDCFB-128-J60 (JAN: 4523052000300)  256MB SDCFB-256-J60 (JAN: 4523052000317)  512MB SDCFB-512-J60 (JAN: 4523052000324)  1.0GB SDCFB-1024-J60 (JAN: 4523052000331)  PCCARD adapter SDAD-38-J60 (JAN: 4523052000645)</p> <p>The performance of the above recommended products were checked under given conditions. The same performance may not be attained at the end-user side because of the difference in system environment. Also, no absolute performance guarantee can be provided even for the same type name as its constituent parts may differ.</p> <p>Some products may have been discontinued. Contact the respective manufacturer or distributor for inquiries about orders.</p>
PCMCIA card	Same as above
PS2 keyboard	<p>MITSUBISHI will not provide performance guarantee and maintenance for commercially available keyboard. Commercially available devices may not be compatible with MITSUBISHI units or suitable for FA environment for temperature- or noise-wise. In the case of using it, careful performance check must be required by the machine tool builder.</p> <p>Cable must be connected/disconnected after turning the unit's power OFF.</p>
PS2 mouse	<p>MITSUBISHI will not provide performance guarantee and maintenance for commercially available mouse. Commercially available devices may not be compatible with MITSUBISHI units or suitable for FA environment for temperature- or noise-wise. In the case of using it, careful performance check must be required by the machine tool builder.</p> <p>Cable must be connected/disconnected after turning the unit's power OFF.</p>

## Appendix 9. Precautions for Use of Peripheral Devices and Commercially Available Devices

Peripheral device	Precautions
USB keyboard	MITSUBISHI will not provide performance guarantee and maintenance for commercially available USB keyboard. Commercially available devices may not be compatible with MITSUBISHI units or suitable for FA environment for temperature- or noise-wise. In the case of using it, careful performance check must be required by the machine tool builder.
	Commercially available USB keyboard is only available when developing applications or during maintenance. It is not designed to be integrated into the unit.
	Commercially available USB keyboard is susceptible to noise, etc. and may cause a malfunction in the unit that may lead to an accident. Do not use it while the machine is operated.
	The performance of USB devices under plug-and-play is not guaranteed. When inserting/removing USB devices, always turn the MITSUBISHI device's power OFF.
	USB1 on the back of the display unit is used for mounting the MITSUBISHI keyboard unit.
USB mouse	Same as above
Other USB devices	MITSUBISHI will not provide performance guarantee and maintenance for commercially available USB printer, USB floppy disk, USB memory, USB hub, USB-CDROM, USB-DVDRAM, and other USB devices. Commercially available devices may not be compatible with MITSUBISHI units or suitable for FA environment for temperature- or noise-wise. In the case of using it, careful performance check must be required by the machine tool builder, and necessary noise countermeasures, such as executing EMI countermeasures or adding the ferrite cores, must be taken.
	Other restrictions are the same as for USB keyboard.
Other precautions on USB	<p>The maximum USB bus power (5VDC) that can be supplied from USB1 or USB2 connector on the back of the display unit is 500mA each. Also, the maximum USB bus power (5VDC) that can be supplied from the front IC card USB connector is 100mA.</p> <p>When connecting a commercially available USB device that requires power exceeding the maximum current, select the one of which power can be supplied from an outside source. However, MITSUBISHI will not provide performance guarantee and maintenance for commercially available USB devices. Commercially available devices may not be compatible with MITSUBISHI units or suitable for FA environment for temperature- or noise-wise. In the case of using it, careful performance check must be required by the machine tool builder.</p>
About shutting down	Always turn the power OFF after confirming the normal shutdown has been performed. Failure to observe this could cause a malfunction. If the normal shutdown failed, contact your local service department without turning the power OFF.
Hard disk	Mount the hard disk unit within $\pm 15^\circ$ with the cable lead-out side facing straight up.
	Do not turn the power OFF during access to the hard disk. Failure to observe this could cause a malfunction. In case of emergency, always perform backups by having your important data duplicated, etc. as MITSUBISHI will not guarantee the broken or lost data. Be sure to inform this matter to the end users.



## Appendix 9. Precautions for Use of Peripheral Devices and Commercially Available Devices

Peripheral device	Precautions
Printer	<p>MITSUBISHI will not provide performance guarantee and maintenance for commercially available printers and other external devices. Commercially available devices may not be compatible with MITSUBISHI units or suitable for FA environment for temperature- or noise-wise. In the case of using it, careful performance check must be required by the machine tool builder.</p> <p>When connecting/disconnecting cables, always turn OFF all the power of the unit and printer. Startup the printer and the unit simultaneously, or power ON the printer before the unit power is turned ON.</p>
Floppy disk drive	<p>The mode available for MITSUBISHI floppy disk drive is "2" (720k/1.44M bytes) only.</p> <p>MITSUBISHI will not provide performance guarantee and maintenance for commercially available floppy disk drives. Commercially available devices may not be compatible with MITSUBISHI units or suitable for FA environment for temperature- or noise-wise. In the case of using it, careful performance check must be required by the machine tool builder.</p> <p>Do not pull out the floppy disk or turn OFF the power during access to the floppy disk. Failure to observe this could cause the memory contents to be erased. In case of emergency, always perform backups by having your important data duplicated, etc. as MITSUBISHI will not guarantee the broken or lost data. Be sure to inform this matter to the end users.</p>
Optical fiber cable	<p>Optical fiber cables cannot be manufactured by the machine tool builder. Always use the cables manufactured by MITSUBISHI. When optical fiber cables manufactured by other than MITSUBISHI are used, malfunctions resulted from connection problems or aged deterioration are not covered under the warranty.</p>

## Revision History

Date of revision	Manual No.	Revision details
Jun. 2004	IB(NA)1500034-B	First edition created.
Nov. 2004	IB(NA)1500034-C	<ul style="list-style-type: none"> <li>• "2.2 Appearance of control unit" deleted.</li> <li>• "2.3.9 Hard disk unit" added.</li> <li>• "4.5 Hard disk unit" added.</li> <li>• "5.5 Hard disk unit" added.</li> <li>• "5.6 External power supply unit" added.</li> <li>• "5.7 Remote I/O unit" added.</li> <li>• "Appendix 3. Connectors" completely revised.</li> <li>• "Appendix 5. Precautions for wiring M700 Series" added.</li> <li>• Mistakes corrected.</li> </ul>
Jun. 2005	IB(NA)1500034-D	<ul style="list-style-type: none"> <li>• The following chapters and sections were added.                2.3.7, 2.3.11 to 2.3.14, 4.2.5, 4.6, 4.7, 5.8 to 5.10, 6 to 9                Appendix 2.2, 2.3, 2.8, 2.9, 2.20, 2.22, 2.30, 2.33, 2.34, 5.3 to 5.6, 6 to 8</li> <li>• Appendix.1.15 was deleted.</li> <li>• Contents regarding expansion unit and expansion card PROFIBUS-DP were added, and the related sections were corrected.</li> <li>• Mistakes were corrected.</li> </ul>
Mar. 2007	IB(NA)1500034-E	<ul style="list-style-type: none"> <li>• 15-type LCD was included in the contents.</li> <li>• Contents regarding MDS-D-SVJ3/MDS-D-SPJ3 were added.</li> <li>• Mistakes were corrected.</li> </ul>

# Global service network

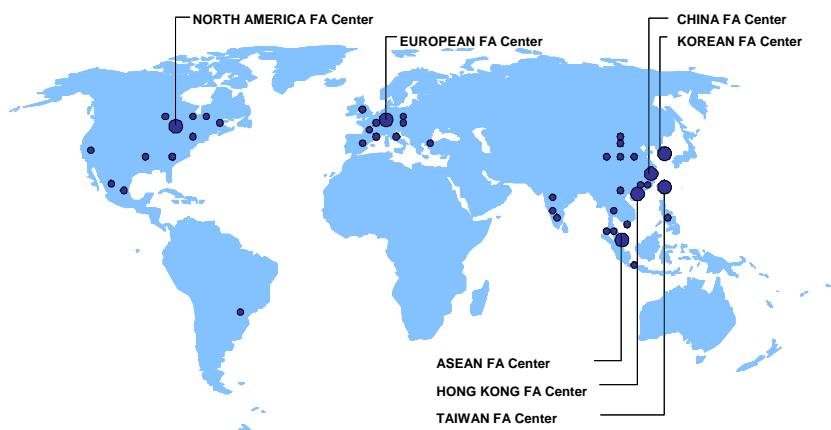

## North America FA Center (MITSUBISHI ELECTRIC AUTOMATION INC.)

**Illinois CNC Service Center**  
500 CORPORATE WOODS PARKWAY, VERNON HILLS, IL, 60061, U.S.A.  
TEL: +1-847-478-2500 (Se) FAX: +1-847-478-2650 (Se)

**California CNC Service Center**  
5665 PLAZA DRIVE, CYPRESS, CA, 90630, U.S.A.  
TEL: +1-714-220-4796 FAX: +1-714-229-3818

**Georgia CNC Service Center**  
2810 PREMIERE PARKWAY SUITE 400, DULUTH, GA., 30097, U.S.A.  
TEL: +1-678-258-4500 FAX: +1-678-258-4519

**New Jersey CNC Service Center**  
200 COTTONTAIL LANE SOMERSET, NJ, 08873, U.S.A.  
TEL: +1-732-560-4500 FAX: +1-732-560-4531

**Michigan CNC Service Satellite**  
2545 38TH STREET, ALLEGAN, MI., 49010, U.S.A.  
TEL: +1-847-478-2500 FAX: +1-269-673-4092

**Ohio CNC Service Satellite**  
62 W. 500 S., ANDERSON, IN., 46013, U.S.A.  
TEL: +1-847-478-2609 FAX: +1-847-478-2690

**Texas CNC Service Satellite**  
1000, NOLEN DRIVE SUITE 200, GRAPEVINE, TX, 76051, U.S.A.  
TEL: +1-817-251-7468 FAX: +1-817-416-1439

**Canada CNC Service Center**  
4299 14TH AVENUE MARKHAM, ON. L3R 0J2, CANADA  
TEL: +1-905-475-7728 FAX: +1-905-475-7935

**Mexico CNC Service Center**  
MARIANO ESCOBEDO 69 TLALNEPANTLA, 54030 EDO. DE MEXICO  
TEL: +52-55-9171-7662 FAX: +52-55-9171-7698

**Monterrey CNC Service Satellite**  
ARGENTINA 3900, FRACC. LAS TORRES, MONTERREY, N.L., 64720, MEXICO  
TEL: +52-81-8365-4171 FAX: +52-81-8365-4171

**Brazil MITSUBISHI CNC Agent Service Center**  
(AUTOMOTION IND. COM. IMP. E EXP. LTDA.)  
ACESSO JOSE SARTORELLI, KM 2.1 18550-000 BOITUVA – SP, BRAZIL  
TEL: +55-15-3363-9900 FAX: +55-15-3363-9911

## European FA Center (MITSUBISHI ELECTRIC EUROPE B.V.)

**Germany CNC Service Center**  
GOTHAER STRASSE 8, 40880 RATINGEN, GERMANY  
TEL: +49-2102-486-0 FAX: +49-2102486-591

**South Germany CNC Service Center**  
KURZE STRASSE. 40, 70794 FILDERSSTADT-BONLANDEN, GERMANY  
TEL: +49-711-3270-010 FAX: +49-711-3270-0141

**France CNC Service Center**  
25, BOULEVARD DES BOUVETS, 92741 NANTERRE CEDEX FRANCE  
TEL: +33-1-41-02-83-13 FAX: +33-1-49-01-07-25

**Lyon CNC Service Satellite**

**U.K CNC Service Center**  
TRAVELLERS LANE, HATFIELD, HERTFORDSHIRE, AL10 8XB, U.K.  
TEL: +44-1707-282-946 FAX: +44-1707-278-992

**Italy CNC Service Center**  
ZONA INDUSTRIALE VIA ARCHIMEDE 35 20041 AGRATE BRIANZA, MILANO ITALY  
TEL: +39-039-60531-342 FAX: +39-039-6053-206

**Spain CNC Service Satellite**  
CTRA. DE RUBI, 76-80 -APDO.420 08190 SAINT CUGAT DEL VALLES, BARCELONA SPAIN  
TEL: +34-935-65-2236 FAX:

**Turkey MITSUBISHI CNC Agent Service Center**  
(GENEL TEKNİK SİSTEMLER LTD. STI.)  
DARULACEZE CAD. FAMAS İS MERKEZİ A BLOK NO.43 KAT2 80270 OKMEYDANI İSTANBUL, TURKEY  
TEL: +90-212-320-1640 FAX: +90-212-320-1649

**Poland MITSUBISHI CNC Agent Service Center (MPL Technology Sp. z. o. o)**  
UL SŁICZNA 34, 31-444 KRAKOW, POLAND  
TEL: +48-12-632-28-85 FAX:

**Wrocław MITSUBISHI CNC Agent Service Satellite (MPL Technology Sp. z. o. o)**  
UL KOBIERZYCKA 23, 52-315 WROCLAW, POLAND  
TEL: +48-71-333-77-53 FAX: +48-71-333-77-53

**Czech MITSUBISHI CNC Agent Service Center**  
(AUTOCONT CONTROL SYSTEM S.R.O. )  
NEMOCNICNI 12, 702 00 OSTRAVA 2 CZECH REPUBLIC  
TEL: +420-596-152-426 FAX: +420-596-152-112

## ASEAN FA Center (MITSUBISHI ELECTRIC ASIA PTE. LTD.)

**Singapore CNC Service Center**  
307 ALEXANDRA ROAD #05-01/02 MITSUBISHI ELECTRIC BUILDING SINGAPORE 159943  
TEL: +65-6473-2308 FAX: +65-6476-7439

**Thailand MITSUBISHI CNC Agent Service Center (F. A. TECH CO., LTD)**  
898/19,20,21,22 S.V. CITY BUILDING OFFICE TOWER 1 FLOOR 12,14 RAMA III RD BANGPONGPANG, YANNAWA, BANGKOK 10120, THAILAND  
TEL: +66-2-682-6522 FAX: +66-2-682-6020

**Malaysia MITSUBISHI CNC Agent Service Center**  
(FLEXIBLE AUTOMATION SYSTEM SDN. BHD.)  
60, JALAN USJ 10/1B 47620 UEP SUBANG JAYA SELANGOR DARUL EHSAN MALAYSIA  
TEL: +60-3-5631-7605 FAX: +60-3-5631-7636

**JOHOR MITSUBISHI CNC Agent Service Satellite**  
(FLEXIBLE AUTOMATION SYSTEM SDN. BHD.)  
NO. 16, JALAN SHAHBANDAR 1, TAMAN UNGKU TUN AMINAH, 81300 SKUDAI, JOHOR MALAYSIA  
TEL: +60-7-557-8218 FAX: +60-7-557-3404

**Indonesia MITSUBISHI CNC Agent Service Center**  
(PT. AUTOTEKNIKINDO SUMBER MAKMUR)  
WISMA NUSANTARA 14TH FLOOR JL. M.H. THAMRIN 59, JAKARTA 10350 INDONESIA  
TEL: +62-21-3917-144 FAX: +62-21-3917-164

**India MITSUBISHI CNC Agent Service Center (MESSUNG SALES & SERVICES PVT. LTD.)**  
B-36FF, PAVANA INDUSTRIAL PREMISES M.I.D.C., BHOASRI PUNE 411026, INDIA  
TEL: +91-20-2711-9484 FAX: +91-20-2712-8115

**BANGALORE MITSUBISHI CNC Agent Service Satellite**  
(MESSUNG SALES & SERVICES PVT. LTD.)  
S 615, 6TH FLOOR, MANIPAL CENTER, BANGALORE 560001, INDIA  
TEL: +91-80-509-2119 FAX: +91-80-532-0480

**Delhi MITSUBISHI CNC Agent Parts Center (MESSUNG SALES & SERVICES PVT. LTD.)**  
1197, SECTOR 15 PART-2, OFF DELHI-JAIPUR HIGHWAY BEHIND 32ND MILESTONE GURGAON 122001, INDIA  
TEL: +91-98-1024-8895 FAX:

**Philippines MITSUBISHI CNC Agent Service Center**  
(FLEXIBLE AUTOMATION SYSTEM CORPORATION)  
UNIT No.411, ALABAMG CORPORATE CENTER KM 25, WEST SERVICE ROAD SOUTH SUPERHIGHWAY, ALABAMG MUNTINLUPA METRO MANILA, PHILIPPINES 1771  
TEL: +63-2-807-2416 FAX: +63-2-807-2417

**Vietnam MITSUBISHI CNC Agent Service Center (SA GIANG TECHNO CO., LTD)**  
47-49 HOANG SA ST. DAKAO WARD, DIST.1 HO CHI MINH CITY, VIETNAM  
TEL: +84-8-910-4763 FAX: +84-8-910-2593

## China FA Center (MITSUBISHI ELECTRIC AUTOMATION (SHANGHAI) LTD.)

**China CNC Service Center**  
2/F, BLOCK 5 BLDG.AUTOMATION INSTRUMENTATION PLAZA, 103 CAOBAO RD. SHANGHAI 200233, CHINA  
TEL: +86-21-6120-0808 FAX: +86-21-6494-0178

**Shenyang CNC Service Center**  
TEL: +86-24-2397-0184 FAX: +86-24-2397-0185

**Beijing CNC Service Satellite**  
9/F, OFFICE TOWER1, HENDERSON CENTER, 18 JIANGUOMENNEI DAJIE, DONGCHENG DISTRICT, BEIJING 100005, CHINA  
TEL: +86-10-6518-8830 FAX: +86-10-6518-8030

**China MITSUBISHI CNC Agent Service Center**  
(BEIJING JIAYOU HIGTECH TECHNOLOGY DEVELOPMENT CO.)  
RM 709, HIGH TECHNOLOGY BUILDING NO.229 NORTH SI HUAN ZHONG ROAD, HAIDIAN DISTRICT, BEIJING 100083, CHINA  
TEL: +86-10-8288-3030 FAX: +86-10-6518-8030

**Tianjin CNC Service Satellite**  
RM909, TAIHONG TOWER, NO220 SHIZILIN STREET, HEBEI DISTRICT, TIANJIN, CHINA 300143  
TEL: +86-22-2653-9090 FAX: +86-22-2635-9050

**Shenzhen CNC Service Satellite**  
RM02, UNIT A, 13/F, TIANAN NATIONAL TOWER, RENMING SOUTH ROAD, SHENZHEN, CHINA 518005  
TEL: +86-755-2515-6691 FAX: +86-755-8218-4776

**Changchun Service Satellite**  
TEL: +86-431-50214546 FAX: +86-431-5021690

**Hong Kong CNC Service Center**  
UNIT A, 25/F RYODEN INDUSTRIAL CENTRE, 26-38 TA CHUEN PING STREET, KWAI CHUNG, NEW TERRITORIES, HONG KONG  
TEL: +852-2619-8588 FAX: +852-2784-1323

## Taiwan FA Center (MITSUBISHI ELECTRIC TAIWAN CO., LTD.)

**Taichung CNC Service Center**  
NO.8-1, GONG YEH 16TH RD., TAICHUNG INDUSTRIAL PARK TAICHUNG CITY, TAIWAN R.O.C.  
TEL: +886-4-2359-0688 FAX: +886-4-2359-0689

**Taipei CNC Service Satellite**  
TEL: +886-4-2359-0688 FAX: +886-4-2359-0689

**Tainan CNC Service Satellite**  
TEL: +886-4-2359-0688 FAX: +886-4-2359-0689

## Korean FA Center (MITSUBISHI ELECTRIC AUTOMATION KOREA CO., LTD.)

**Korea CNC Service Center**  
1480-6, GAYANG-DONG, GANGSEO-GU SEOUL 157-200, KOREA  
TEL: +82-2-3660-9631 FAX: +82-2-3664-8668

## **Notice**

Every effort has been made to keep up with software and hardware revisions in the contents described in this manual. However, please understand that in some unavoidable cases simultaneous revision is not possible.

Please contact your Mitsubishi Electric dealer with any questions or comments regarding the use of this product.

## **Duplication Prohibited**

This manual may not be reproduced in any form, in part or in whole, without written permission from Mitsubishi Electric Corporation.

© 2004-2007 MITSUBISHI ELECTRIC CORPORATION  
ALL RIGHTS RESERVED.

# MITSUBISHI CNC



MODEL	700 Series
MODEL CODE	008—315
Manual No.	IB-1500034 (ENG)